

---

# ROCKY BRANCH WATERSHED ASSESSMENT

---



MAY 20, 2016

---

PREPARED FOR:



CITY OF COLUMBIA  
UTILITY AND ENGINEERING DEPARTMENT  
1136 WASHINGTON STREET, 7TH FLOOR  
COLUMBIA, SOUTH CAROLINA 29201

PREPARED BY:



1441 MAIN STREET  
SUITE 875  
COLUMBIA, SOUTH CAROLINA 29201  
(410) 662-7400

IN ASSOCIATION WITH:



4000 FABRE PLACE DRIVE  
SUITE 300  
NORTH CHARLESTON,  
SOUTH CAROLINA 29405



## Table of Contents

1.0	Introduction.....	6
2.0	Study Objectives .....	6
3.0	Watershed Background.....	6
3.1	History.....	8
3.2	Geology.....	8
3.3	Ecoregion .....	9
3.4	Soils.....	9
3.5	Water Quality.....	10
3.6	Biological Data .....	10
4.0	Detailed Watershed Assessment.....	10
4.1	Stream Cruising Effort.....	11
4.2	Watershed Characterization .....	13
4.2.1	Subwatershed Breakouts.....	13
4.3	Hydrologic and Hydraulic (H&H) Analysis.....	15
4.3.1	Model Development.....	17
4.3.2	Gage Results in HEC-RAS .....	20
4.3.3	Flow Results.....	21
4.3.4	Water Surface Profile Evaluation .....	23
4.3.5	Results from Culvert Analysis.....	25
4.3.6	Water Storage Analysis.....	26
4.3.7	Recommendations for Future Watershed Studies.....	26
5.0	Subwatershed Ranking.....	28
6.0	Detailed Subwatershed Assessment Results.....	30
6.1	Gregg Street (GS) Subwatershed .....	33
6.2	University of South Carolina Campus (USC) Subwatershed .....	42
6.3	Mill Villages A (MV-A) Subwatershed.....	50
6.4	University Hill (UH) subwatershed .....	59
6.5	Martin Luther King Jr. (MLK) Subwatershed .....	66
6.6	Devine Blossom (DB) Subwatershed .....	74
6.7	Rosewood (RW) Subwatershed .....	80
6.8	Hollywood-Rose Hill (HRH) Subwatershed .....	88
6.9	Fairgrounds (FG) Subwatershed.....	94



6.10 Mill Villages B (MV-B) Subwatershed ..... 101

6.11 Outlet (OT) Subwatershed ..... 109

7.0 Restoration Strategies ..... 116

7.1 Municipal and Institutional Strategies ..... 116

7.1.1 Stormwater Retrofits ..... 117

7.1.1.1 Low Impact Design ..... 118

7.1.1.1.1 Impervious Cover Removal ..... 118

7.1.1.1.2 Bioretention and Rain Gardens ..... 118

7.1.1.1.3 Green Roofs ..... 119

7.1.1.1.4 Green Streets ..... 119

7.1.1.1.5 Boulevard Approach ..... 119

7.1.1.1.6 Rain Harvesting (Cisterns) ..... 120

7.1.1.2 Stormwater Management Facilities ..... 120

7.1.1.3 Stream Restoration ..... 120

7.1.1.4 Reforestation/Buffer Establishment ..... 121

7.1.1.5 Infrastructure Improvement ..... 121

7.1.2 Enhanced Stormwater Management Requirements ..... 122

7.1.3 Stormwater Education and Outreach ..... 123

7.1.4 Tree Planting Incentives Programs ..... 123

7.2 Citizen-Based Strategies ..... 123

7.2.1 Downspout Disconnection ..... 124

7.2.2 Residential Nutrient Management and Lawn Maintenance ..... 124

7.3 Evaluation of Restoration Opportunities ..... 124

8.0 Watershed Project Identification and Prioritization ..... 126

9.0 Conclusions and Limitations ..... 134

References ..... 137



**List of Figures**

Figure 3.1 Project Location..... 7

Figure 3.2 Physiographic Provinces of SC ..... 8

Figure 4.1 Watershed Assessment Methodology..... 11

Figure 4.2 Subwatersheds ..... 12

Figure 4.3 SWMM Model Layout ..... 17

Figure 4.4 ROCA SWMM Model and Stream Gage Comparison ..... 18

Figure 4.5 USGS Whaley SWMM Model and Stream Gage Comparison..... 19

Figure 4.6 ROCB SWMM Model and Stream Gage Comparison..... 19

Figure 4.7 ROCA June 3, 2015 Storm..... 20

Figure 4.8 ROCB June 3, 2015 Storm ..... 20

Figure 4.9 10-Year HEC-RAS Results ..... 22

Figure 5.1 Subwatershed Ranking ..... 29

Figure 6.1 Subwatershed Land Use ..... 31

Figure 6.2 Gregg Street Subwatershed ..... 33

Figure 6.3 GS Soils ..... 34

Figure 6.4 GS Existing Conditions ..... 35

Figure 6.5 GS SWMM Model ..... 39

Figure 6.6 GS Restoration Opportunities..... 41

Figure 6.7 University of South Carolina Subwatershed ..... 42

Figure 6.8 USC Soils ..... 43

Figure 6.9 USC Existing Conditions ..... 44

Figure 6.10 USC SWMM Model..... 47

Figure 6.11 USC Restoration Opportunities ..... 49

Figure 6.12 Mill Villages A Subwatershed..... 50

Figure 6.13 MV-A Soils ..... 51

Figure 6.14 MV-A Existing Conditions..... 52

Figure 6.15 MV-A SWMM Model..... 56

Figure 6.16 MV-A Restoration Opportunities ..... 58

Figure 6.17 University Hill Subwatershed..... 59

Figure 6.18 UH Soils ..... 60

Figure 6.19 UH Existing Conditions ..... 61

Figure 6.20 UH SWMM Model..... 63

Figure 6.21 UH Restoration Opportunities ..... 65

Figure 6.22 Martin Luther King Jr. Subwatershed ..... 66

Figure 6.23 MLK Soils ..... 67

Figure 6.24 MLK Existing Conditions ..... 68

Figure 6.25 MLK SWMM Model..... 71

Figure 6.26 MLK Restoration Opportunities..... 73

Figure 6.27 Devine Blossom Subwatershed ..... 74

Figure 6.28 DB Soils..... 75

Figure 6.29 DB Existing Conditions..... 76

Figure 6.30 DB SWMM Model ..... 78

Figure 6.31 DB Restoration Opportunities ..... 79

Figure 6.32 Rosewood Subwatershed..... 80

Figure 6.33 RW Soils..... 81



Figure 6.34 RW Existing Conditions..... 82

Figure 6.35 RW SWMM Model ..... 86

Figure 6.36 RW Restoration Opportunities ..... 87

Figure 6.37 Hollywood-Rose Hill Subwatershed ..... 88

Figure 6.38 HRH Soils..... 89

Figure 6.39 HRH Existing Conditions..... 90

Figure 6.40 HRH SWMM Model ..... 92

Figure 6.41 HRH Restoration Opportunities ..... 93

Figure 6.42 Fairgrounds Subwatershed ..... 94

Figure 6.43 FG Soils ..... 95

Figure 6.44 FG Existing Conditions ..... 96

Figure 6.45 FG SWMM Model ..... 98

Figure 6.46 FG Restoration Opportunities..... 100

Figure 6.47 Mill Villages B Subwatershed..... 101

Figure 6.48 MV-B Soils..... 102

Figure 6.49 MV-B Existing Conditions..... 103

Figure 6.50 MV-B SWMM Model ..... 106

Figure 6.51 MV-B Restoration Opportunities ..... 108

Figure 6.52 Outlet Subwatershed..... 109

Figure 6.53 OT Soils..... 110

Figure 6.54 OT Existing Conditions..... 111

Figure 6.55 OT SWMM Model ..... 113

Figure 6.56 OT Restoration Opportunities ..... 115

Figure 7.1 Example City of Columbia Educational Program: My River Starts Here..... 123

Figure 8.1 Individual Restoration Project Identification ..... 128

**List of Tables**

Table 3.1 Rocky Branch Watershed Hydrologic Soils Group Distribution..... 9

Table 3.2 Rocky Branch Watershed Soil Descriptions..... 10

Table 4.1 Data Collected During the Stream Cruising Effort..... 14

Table 4.2 2015 FIS Existing HEC-RAS Flows ..... 21

Table 4.3 2016 SWMM Flows..... 21

Table 4.4 Culvert Analysis Scenario 1: Olympia Avenue, Olympia Railroad, Bluff Road and Southern Railroad 02 Culvert Replacements ..... 24

Table 4.5 Culvert Analysis Scenario 2: Addition of Whaley and Catawba Culvert Replacements to Scenario 1 ..... 25

Table 4.6 Comparison of Culvert Analysis Scenarios ..... 26

Table 4.7 Comparison of 2016 SWMM Flows with MLK Detention Alternative..... 26

Table 5.1 Subwatershed Runoff Rankings (2-year Storm Event)..... 28

Table 6.1 Subwatershed Land Use..... 32

Table 8.1 Individual Project Identification and Description..... 129

Table 8.2 Subwatershed Water Quality Volume ..... 133



---

## Appendices

Appendix A: Historic Aerial Photos

Appendix B: Water Quality Data

Appendix C: Field Data Dictionary (Stream Cruising Effort)

Appendix D: Design Solutions



## 1.0 Introduction

McCormick Taylor Inc., supported by KCI Technologies, Inc., has been contracted by the City of Columbia, South Carolina to conduct an assessment of the Rocky Branch watershed to identify potential improvement opportunities to identify existing flooding and water quality conditions.

This report extensively documents the existing conditions for the Rocky Branch Watershed and describes the methodology and results of a study to identify and prioritize restoration opportunities. The watershed was evaluated based on ecologic, hydrologic and hydraulic functions to characterize existing conditions and highlight potential restoration opportunities.

## 2.0 Study Objectives

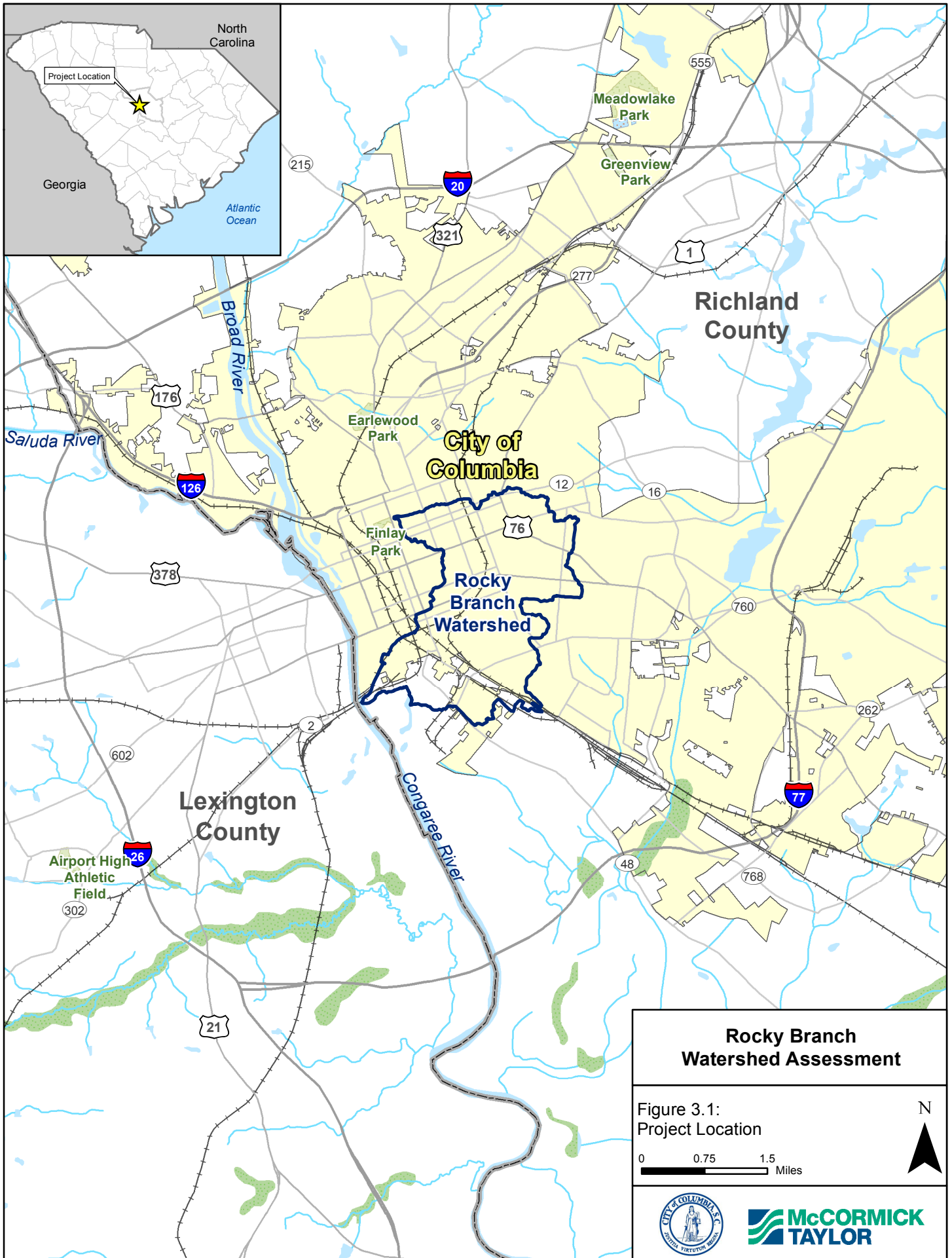
There are a number of objectives sought from the development of this report. Determining the existing conditions of the watershed as a baseline for the assessment was of foremost importance. Understanding the existing conditions allowed the team to evaluate the predominant needs of the watershed by assessing, in detail, the physical characteristics that contribute to its overall condition.

Once the team characterized the condition of the watershed, further assessment of the need and location for potential restoration initiatives was undertaken. This was completed through a series of detailed evaluations which assessed the restoration need and potential across the watershed, specifically focusing on improving water quality and reducing flood risk.

The assessments of existing conditions and restoration potential were then collectively reviewed to arrive at the ultimate objective of identifying Watershed Projects in areas of greatest need within the watershed. These projects are focused on achieving the observed needs of the watershed and may be undertaken by various organizations (government entities, businesses, non-profit organizations, etc.).

## 3.0 Watershed Background

The Rocky Branch Watershed is primarily located in the City of Columbia, SC (**Figure 3.1**). The watershed is approximately four square miles and includes 5.6 miles of open stream channel which drains to the Congaree River. The watershed is home to the central portion of the University of South Carolina (USC) Campus, including a portion of the Williams-Brice Stadium for USC football and associated infrastructure, State Fairgrounds, Five Points District, Olympia, Maxcy Gregg and Martin Luther King Jr. (MLK) Parks and an active sand and gravel mine owned by Vulcan Materials. The dominant land uses within the Rocky Branch Watershed, as of 2011, includes developed land of high, medium, and low density. Total imperviousness within the Rocky Branch watershed is 49%. The high imperviousness of the watershed combined with minimal stormwater controls and under-sized conveyances create flooding conditions on a frequent basis. The Center for Watershed Protection (CWP) studied the effects of imperviousness on channel and watershed conditions; the high imperviousness of the Rocky Branch Watershed classifies it in the upper range of the non-supporting streams category. Non-supporting streams no longer support their designated uses (biological indicators, channel stability, habitat, hydrology and water quality) and primary restoration goals should be to reduce pollutants, improve the stream corridor, or enhance community aesthetics (Schueler, 2005).



**Rocky Branch  
Watershed Assessment**

Figure 3.1:  
Project Location

0 0.75 1.5  
Miles



### 3.1 History

The Rocky Branch watershed is mainly within the City of Columbia, South Carolina. Columbia was first settled as a frontier fort in the mid 1700's. In 1786, Columbia was designated as the state capital of South Carolina and was later chartered as a town in 1805 with a population of over 1,000. Initially the city was two square miles that ran along the eastern bank of the Congaree River. Suburbs began to form in 1870 as the population grew. The streets were first paved with asphalt in 1925 (City of Columbia, 2016).

Historical aerial photographs were analyzed for the following years: 1938, 1959, 1970, 1981, 1995, 2006, and each year between 2010 and 2015 to assess changes in land cover and watershed condition. The central portion of the watershed was already a well-established urban development by 1938. The most noticeable differences between 1938 and present day were seen at the mouth of Rocky Branch and within the headwaters. Lower and upper portions of the watershed were still agricultural in the 1938 aerial, though by 1959 the regions were more noticeably urbanized. The establishment of the Vulcan Materials Company mine can be seen between 1938 and 1959, resulting in alteration of the Rocky Branch confluence with the Congaree River (**Appendix A**). As the mine expanded, Rocky Branch was shifted further north, until the channel became pinched between the mine and the railroad to the north (can first be seen in the 1995 aerial).

### 3.2 Geology

The Rocky Branch watershed is located adjacent to the Congaree River and along the Fall Line, where the Coastal Plain adjoins the Piedmont province (**Figure 3.2**). The watershed is primarily characterized by the Cape Fear (Kcfe) and Peedee (Kpb) Formations of the inner Coastal Plain, formed during the upper Cretaceous. The Cape Fear formation consists of light-colored cross-bedded arkosic sand, gravel deposited in delta-dominated fluvial environments, and lenses of massive light-colored clay and kaolin with many local unconformities. The Peedee Formation consists of dark green or gray glauconitic and argillitic sand, many layers of which are calcareous (United States Department of Agriculture Soil Conservation Service, 1978).

**Figure 3.2 Physiographic Provinces of SC**



The southwestern portion of the watershed consists of Tertiary sand, clay, or mud deposits (Td) that are likely Pliocene in age, as well as more recent alluvial sand and gravel along the Congaree River. A small portion in the northwest of the watershed is located within the Columbia granite Pluton (Cgcl) of the Piedmont.

The dominant formations in the watershed are composed of unconsolidated and soft or soluble deposits that are more easily eroded than the granites, gneisses, and schists below them. Through urbanization and development impervious cover now obscures a large portion of these erodible surfaces. However, locations where these



materials are exposed, particularly unaltered stream banks and sloped areas, are subject to erosion. Degradation was prevalent in these locations during the unprecedented rainfall and flooding event during early October of 2015.

### 3.3 Ecoregion

The Rocky Branch study site is located entirely within the Sandhills ecoregion. The Sandhills ecoregion consists of rolling hills made of cretaceous-age marine sand and clays that are drought-prone and low in nutrients (Griffith, 2002).

Sandhills ecoregion streams typically have a loose sandy bed with indistinct features. The transition from the Piedmont to the Sandhills is evidenced by the broad floodplain landscape of the Congaree River below the confluence of the Broad and Saluda. The channel bed and banks of the Rocky Branch mainstem and tributaries are so extensively altered that they no longer resemble the natural form of a Sandhills stream.

Native riparian habitat within the Sandhills ecoregion consists of longleaf pine stands, hardwood forests, or pocosin-like evergreen shrubs. Small isolated wetlands are key features in the riparian area, providing breeding grounds for the herpetofauna of the region. Longleaf pine forests require frequent fire events to provide bare mineral soil for their seeds to germinate and to limit the establishment of other hardwood tree species. When suitable fire conditions aren't present, hardwood tree species will establish in the narrow floodplain in the low lying areas between the sandhills (SCDNR, 2005). Development of the Rocky Branch watershed has resulted in fragmentation to complete removal of riparian habitat.

### 3.4 Soils

Information on the soils in the study site was obtained from the Web Soil Survey developed by the US Department of Agriculture, National Resources Conservation Service (NRCS). The predominant hydrologic soil group within the watershed is type D, followed by type B and A, respectively. Urban land accounts for over 91% of the soils classified as Group D, Group B soils are silt loam or loam, and Group A soils are sand or gravel. Hydrologic soils are grouped from the most well-drained (type A) to the most poorly drained (type D). **Table 3.1** displays the percentage of each hydrologic soil group within the Rocky Branch Watershed.

**Table 3.1 Rocky Branch Watershed Hydrologic Soils Group Distribution**

Hydrologic Soil Group	% Rocky Branch Watershed
A	15%
B	30%
C	0%
D	55%

Mapping of the soils within each subwatershed is found in **Section 6.0**. **Table 3.2** lists the drainage class and parent material for the most commonly found soils within the watershed. Half of the watershed is mapped as Urban land (50.3%). Urban land (Ur) consists of areas covered by asphalt roadways or parking lots, concrete structures, buildings and other impervious surfaces which provide a flashy hydrologic response. Areas where more than 85% of the surface is covered by impervious structures are simply mapped as Urban land. The high imperviousness decreases infiltration and increases runoff. Other complexes in the watershed consist of relatively



undisturbed (parent) soils with areas altered by cutting, filling, or grading in such an intricate pattern that it is not practical to separate them, i.e. Orangeburg-Urban complex. Fill material in altered areas most commonly consists of adjacent soils that were cut or graded, however soil properties may vary.

Table 3.2 Rocky Branch Watershed Soil Descriptions

Soil	Soil Description	Drainage Class	Parent Material
Ur	Urban Land	Poorly Drained	Impervious surface and fill
OgB	Orangeburg-Urban complex	Well drained	Fluviomarine deposits
LkB	Lakeland sand	Excessively drained	Eolian or fluviomarine sands
OgD	Orangeburg-Urban complex	Well drained	Loamy and clayey marine sediments
DuB	Dothan-Urban complex	Well drained	Unconsolidated, medium to fine marine sediments
FyB	Fuquay-Urban complex	Well drained	Sandy over loamy marine or fluviomarine deposits
VaD	Vaucluse loamy sand	Well drained	Fluviomarine or marine deposits
To	Toccoa Loam	Moderately well drained	Loamy and sandy alluvium

### 3.5 Water Quality

Water quality monitoring is managed primarily by the City of Columbia. There are two City of Columbia monitoring stations within the Rocky Branch Watershed: Rocky Branch A (ROCA), which is located near Maxcy Gregg Park, and Rocky Branch B (ROCB), which is located at the Olympia Avenue crossing of Rocky Branch. The parameters analyzed are pH, specific conductance, water temperature, dissolved oxygen, turbidity, E. coli bacteria, total suspended solids, total phosphorus, and total nitrogen. Monitoring data from these stations indicate that E. coli and specific conductance values within the stream may be elevated. For the full report on water quality monitoring at Rocky Branch, see **Appendix B**.

### 3.6 Biological Data

Investigations into available biological data from DHEC and the South Carolina Department of Natural Resources (SCDNR) yielded no specific references to Rocky Branch. Due to the high level of imperviousness within the watershed, extensive channel alteration, and poor water quality throughout the stream network, the system may not be able to support adequate fish and benthic macroinvertebrate communities.

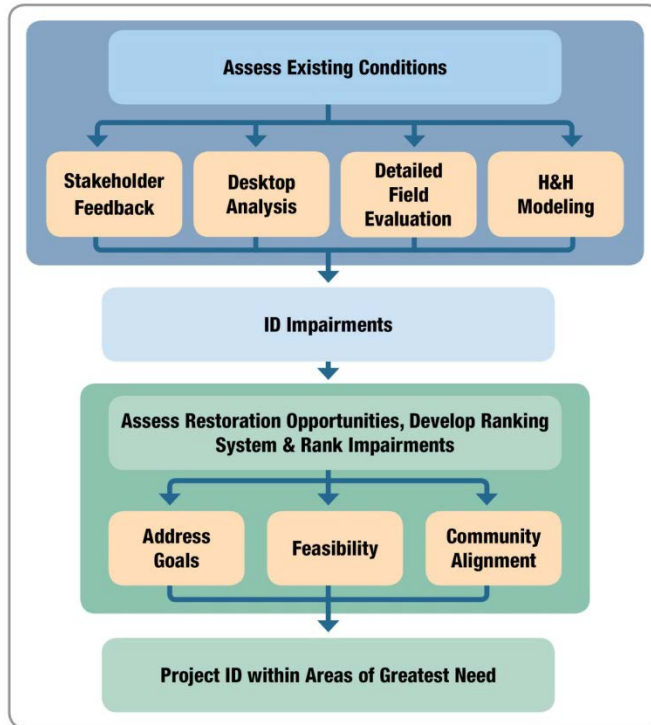
## 4.0 Detailed Watershed Assessment

A multi-faceted methodology was implemented (**Figure 4.1**), first by assessing the existing conditions of the watershed through desktop analysis of existing information as described above. Following desktop analysis and development of a general existing conditions overview, field efforts were initiated. This included conducting a field cruising effort for all open channel



streams to assess the general health of the system based on physical appearance. The goal was to determine the type of impairments existing in the system to better inform the evaluation process.

**Figure 4.1 Watershed Assessment Methodology**



Following the initial assessment, the watershed was portioned into a series of eleven subwatersheds as shown in **Figure 4.2**. Subwatershed breaks were determined by geomorphic and hydrologic breaks observed in Geographic Information System (GIS) data and from the stream cruising effort. The subwatershed breakout is described further in **Section 4.2.1**. Once completed, several evaluations were conducted both in the field, through visual inspection and using GIS data to further evaluate the individual subwatersheds. Following these evaluations, preliminary data review pointed to the high level of urbanization and associated flooding as the primary issues within the watershed. Considering the level of urbanization and complexity of the drainage network, the Storm Water Management Model (SWMM) was used to evaluate and eventually rank each



subwatershed. Based on this ranking, Watershed Projects were identified in subwatersheds with the greatest impairment. This methodology is summarized in **Figure 4.1** and documented in detail below.

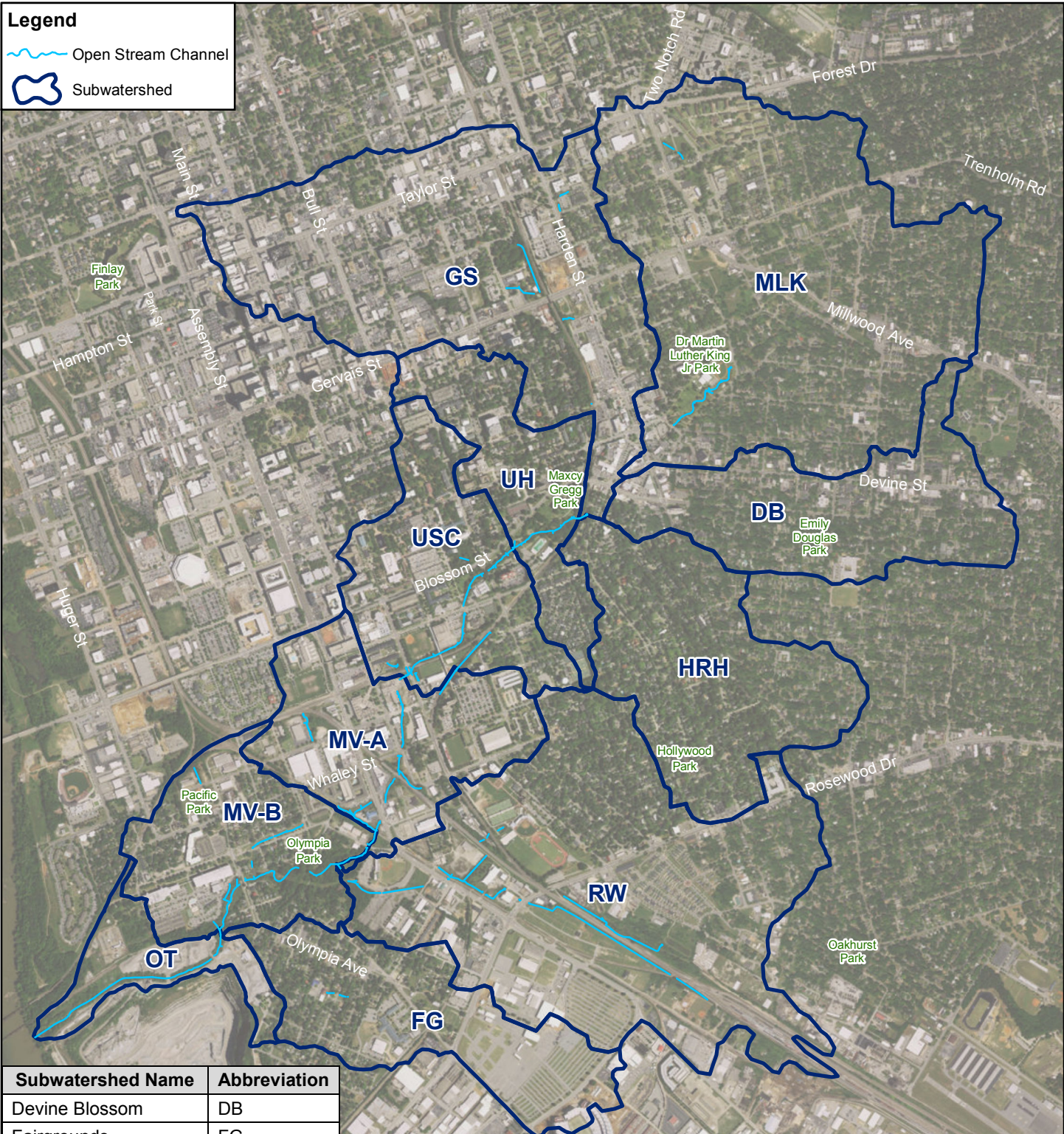
### 4.1 Stream Cruising Effort

The stream cruising effort, loosely based on the Maryland Stream Corridor Assessment (SCA) Survey Protocols (Yetman, 2001), was used to catalog and characterize existing conditions and impairments observed within the stream channel network. The SCA method was originally developed to provide a broad ecosystem based approach to evaluate and restore watersheds in Maryland. It is designed not just to provide information about the location, type, and severity of environmental problems, but inform managers of restoration opportunities within a watershed. Stream cruising efforts were used to rapidly assess the general physical health of the stream system and identify specific problem points.

The stream cruising effort evaluated approximately 30,000 linear feet (5.6 miles) of channel within the Rocky Branch Watershed. Data were collected during the field effort regarding the location, severity, correctability, and accessibility of problem points along the stream network. Environmental problems and conditions that were identified include: Bedrock, Channel Alterations, Erosion Sites, Exposed Pipes, In-stream Habitat, Inadequate Forest Buffers, Near Stream Construction, Pipe Outfalls, Possible Fish Barriers, Representative Photo Site, Trash Dumping Sites, Unmanaged Runoff, and Unusual Conditions.

**Legend**


-  Open Stream Channel
-  Subwatershed






Subwatershed Name	Abbreviation
Devine Blossom	DB
Fairgrounds	FG
Gregg Street	GS
Hollywood-Rose Hill	HRH
Martin Luther King Jr.	MLK
Mill Villages A	MV-A
Mill Villages B	MV-B
Outlet	OT
Rosewood	RW
University Hill	UH
University of South Carolina Campus	USC

**Rocky Branch  
Watershed Assessment**

Figure 4.2:  
Subwatersheds

N  


0 1,000 2,000  
Feet  




Habitat data was collected based on the EPA's Rapid Bioassessment Protocols (Barbour et al. 1999). This information was used to characterize general habitat quality throughout characteristic sections of open channel.

See **Table 4.1** for summary of field data collected within each subwatershed, which lists the frequency of occurrence of each collected feature type. A description of the detailed information noted for each point type is listed in **Appendix C**. The following data were collected for each problem point identified along the stream network during the field effort:

- **Location:** A tablet leveraging the Collector for ArcGIS app was used in conjunction with an external Global Positioning System (GPS) to record a geographic location at sub-meter accuracy and information at each point. The Collector for ArcGIS app uploads the collected features to a web map hosted on ArcGIS Online. Photographs were taken to document location characteristics.
- **Severity:** A ranking was assigned based on a comparison with other problem sites observed in the Watershed.
- **Correctability:** A ranking was assigned based on the extent of the problem and the approximate dollar amount and labor required to correct the observed condition.
- **Accessibility:** A ranking was assigned based upon distance from public roads, slope, vegetation and property ownership surrounding the problem site.

The ArcGIS web map link for all data collected along the 30,000 feet of Rocky Branch channel network will be available to the City upon completion of the study. With appropriate server capabilities and/or through conversion to a GIS platform, the data on the web link can be maintained and utilized as an effective watershed management tool.

## 4.2 Watershed Characterization

The comprehensive field effort provided valuable insight into the existing conditions and nature of stressors within in the watershed. The high level of urbanization throughout the watershed has greatly influenced the condition of the stream network, resulting in extensive channelization, piping and closed storm drains. Channel longitudinal connectivity is severely disrupted and floodplain connectivity is almost non-existent for most of the watershed. Where open channels do exist between long sections of enclosed pipe segments, the excessive flow volume and energy have historically scoured the channel bed and banks. Many of these areas have been stabilized with riprap, loose concrete slabs, timber retaining walls or other armoring. Lack of open channel, limited stormwater management and an excessive amount of impervious surface in the headwater uplands has negatively impacted the downstream network, resulting in widespread water quality and storage issues. Poor water quality and a deficiency of suitable habitat have limited development of a biological community throughout the watershed.

### 4.2.1 Subwatershed Breakouts

The watershed was divided into logical yet manageable subwatersheds for a more detailed evaluation. Utilizing information from the stream cruising effort and the SWMM model, the watershed was divided into eleven subwatersheds as shown in **Figure 4.2**. These subwatersheds were primarily selected based on hydrologic breaks within the watershed. Most of the subwatershed breaks occur at major confluences or road crossings representing a change in



**Table 4.1 Data Collected During the Stream Cruising Effort**

Sub-watershed	Bedrock (#)	Channel Alteration (linear feet)	Erosion Site (linear feet)	Exposed Pipe (#)	Habitat Assessment (#)	Inadequate Forest Buffer (linear feet)	Near Stream Construction (#)	Pipe Outfall (#)	Possible Fish Barrier (#)	Rep. Photo Site (#)	Trash Dump Site (#)	Unman. Runoff (#)	Unusual Condition (#)
OT	0	236	509	2	2	5,065	0	1	0	12	0	0	0
FG	0	174	0	0	2	336	0	4	0	2	0	0	2
MV-B	5	1,956	0	2	5	4,428	0	10	1	8	1	2	8
RW	1	3,037	405	0	5	11,393	0	18	1	39	4	2	8
MV-A	2	2,762	1,114	10	7	7,151	0	37	4	33	0	3	9
USC	0	983	98	5	4	6,039	0	38	2	17	0	4	2
UH	0	59	173	1	1	1,501	0	9	0	4	0	1	3
HRH	0	0	0	0	0	0	0	0	0	0	0	0	0
DB	0	0	0	0	0	0	0	0	0	0	0	0	0
GS	0	625	204	5	3	2,580	1	13	0	17	1	0	8
MLK	0	88	274	2	2	3,491	0	13	1	17	0	0	7
<b>Total</b>	<b>8</b>	<b>9,920</b>	<b>2,778</b>	<b>27</b>	<b>31</b>	<b>41,985</b>	<b>1</b>	<b>143</b>	<b>9</b>	<b>149</b>	<b>6</b>	<b>12</b>	<b>47</b>



channel and/or floodplain condition. The detailed drainage boundaries of each area were derived by evaluating the topography, storm drain system network and digital maps of impervious surfaces.

To compare and prioritize subwatersheds, the data collected from the stream cruising effort were reviewed to identify areas with a density of problem sites. A large portion of these data refer to small scale details within the stream system, requiring physical observation of field conditions. Data representing the larger scale characteristics of the watershed, including land use, property ownership, and soils, were evaluated using GIS. A combination of the field data, GIS and hydrology and hydraulic analysis will be used to identify subwatersheds where restorative efforts should be focused.

### **4.3 Hydrologic and Hydraulic (H&H) Analysis**

Water surface models and the associated data and documentation were collected from sources including the City and Federal Emergency Management Agency (FEMA). The MT/KCI Team has incorporated all of the existing H&H data for the Rocky Branch Watershed. A summary has been made of the origin of the data used in these models and the validity of the assumptions that were used. The previous studies are listed here and described in more detail below:

- 2007 Parsons Brinckerhoff Americas, Inc. (PB) 100% Rocky Branch Watershed Study
- 2007 Summary Review of the HEC-HMS Model
- 2010 FEMA Flood Insurance Study (FIS)
- 2012 AMEC Environment and Infrastructure, Inc. (AMEC) Urban Study on the Rocky Branch Watershed
- 2015 Conditional FEMA FIS
- City GIS Layers

The 2007 PB Study was a study that examined sources and causes of flooding in the Rocky Branch Watershed, included watershed and H&H modeling, and proposed design alternatives for the City. The study contained Hydrologic Engineering Center's River Analysis System (HEC-RAS) Models for existing conditions, culvert improvements, channel improvements, a pond alternative and a tunnel alternative. The existing conditions model contained 88 cross sections and 31 structures that extended 15,006 feet above the confluence with the Congaree River and was run in HEC-RAS 4.1.0 (Hydrologic Engineering Center, 2010). It had scenarios for the 2, 5, 10, 25, 50 and 100-year events, but not the 500-year flood.

This study was based on the Draft Hydrologic Engineering Center's Hydrologic Modeling System (HEC-HMS), Draft HEC-RAS and EPA SWMM Models provided by the United States Army Corps of Engineers (USACE) which were based on a topographic survey completed in 2000. The Study also completed SWMM modeling, focusing on the Five Points area due to the complex nature of the drainage infrastructure and the limitations of HEC-RAS in modeling conduit flow. Most of the alternatives generated from this study were for the 2-year events with the goal of keeping roads passable, especially considering many structures within the watershed were not even able to accommodate a 2-year storm. The alternatives considered consisted of channel and culvert improvements as well as five possible detention areas and a possible tunnel alternative. Three pond locations, one at MLK Park, one at Maxcy Gregg Park, and one at USC Campus were included as a part of this study.



The 2007 HEC-HMS Review was included as Appendix O to the 2007 PB Americas' Study. This review produced corrections and updates to the drainage basins from the HEC-HMS Model in order to better reflect current conditions. The 2007 PB Study also included a culvert near the end of Rocky Branch at the Vulcan Materials mine site that field visits have shown has since been removed, and shows the Williams Street Bridge as a pile supported structure and not the metal arch culvert that exists there at this time.

The 2010 FEMA FIS document provides peak discharges for the 10, 50, 100 and 500-year events at two locations on Rocky Branch and gives a total watershed area of 3.7 square miles. It stated that a majority of the floodplain of Rocky Branch is almost totally developed with permanent commercial buildings and facilities within the University of South Carolina Campus. The FIS document provided study data, profiles and Base Flood Elevations (BFEs) for five cross-sections extending up to 5,000 feet above its confluence with the Congaree River to just past Olympia Avenue. For this study, the FIS did not provide detailed study information needed to extend any analysis farther up the watershed past the outlet of the Five Points Culvert.

The 2012 AMEC Study was completed for the City to examine the effects of a proposed Assembly Street development on the watershed's hydraulics. AMEC concluded that the 2007 PB study was reasonable for its purpose, and updated the extents of the cross-sections used in the 2007 PB HEC-RAS models, keeping the same flow values and channel geometry. Our review of the 2007 PB Model also found that approximately 40 cross-sections needed to be extended in order to meet 100-year floodplain limits, mostly in the areas 5,000 to 10,000 feet upstream of the confluence with the Congaree River. This is one of the areas specified in the Consent Decree, which states "The lower and middle portions of Rocky Branch, starting at the railroad trestle across Blossom Street and ending at the Congaree River, are especially in need of attention." AMEC also updated the flows using the HEC-HMS model downstream of Bluff Road. The Bluff Road culvert and railroad embankments were identified as a primary candidate to be modified in order to provide better upstream conditions. The downstream effects of these modifications were modeled in this study.

The Conditional 2015 FEMA FIS provided new peak discharges for the 10, 50, 100 and 500-year events at three locations on Rocky Branch and gave a slightly larger total watershed area of 4.02 square miles. The peak discharges in this FIS are lower than the ones from the 2010 FIS, despite the increase in basin size. The 2015 FIS also provided study data farther into the watershed, adding 11 cross-sections extending 13,200 feet above the confluence with the Congaree River, where the dual 8 foot by 7 foot culverts discharge from below Five Points.

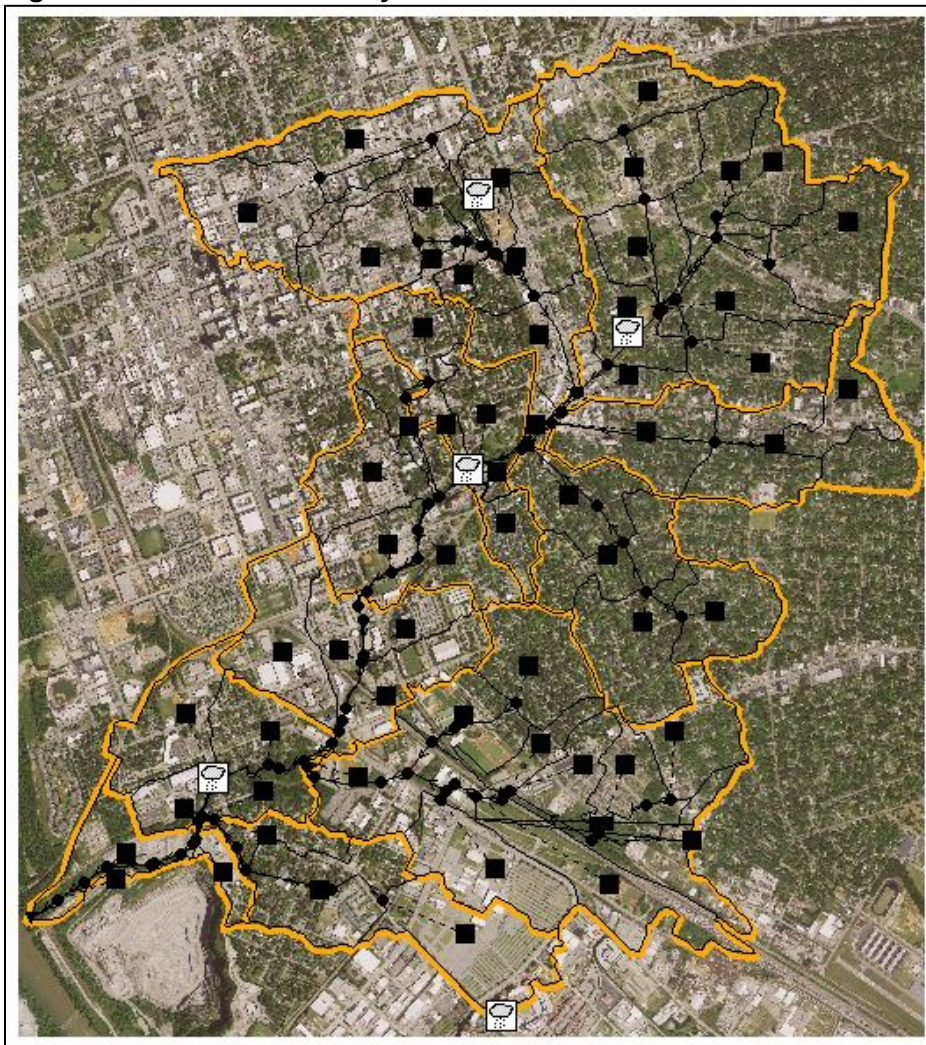
For the H&H analysis, the City GIS layers provided include a Total Impervious Layer which covers the entire watershed, and a storm drain layer which provides information on manholes, inlets, channels and conduits. In the GIS layers for the storm drains, the nodes and links start at Rocky Branch and extend upstream into the watershed. The further upstream of Rocky Branch, the more disconnected the storm drain layer becomes and with little invert elevation information provided. Most culverts and trunk lines have data for diameters and pipe material. In looking at aerial photographs, the storm water BMP Layer appears to have captured most of the wet and dry ponds. It is unknown at this point how many underground BMPs may not be included. There are two separate Basin/Sub-Basin files that have been provided by the University of South Carolina, which are largely coincident with the City's provided watershed boundary.

### 4.3.1 Model Development

KCI prepared H&H models for the Rocky Branch watershed that were used for planning-level assessments of flooding and stream erosion. EPA's SWMM was used for hydrologic calculations, and to derive flows in Rocky Branch at various points. Unlike other hydrologic models such as TR-20 or HEC-HMS, SWMM was originally designed with urban hydrology and storm drain flows in mind. SWMM is also capable of being run either for single events or for continuous rainfall. The nature of the flooding issues in the Rocky Branch watershed and the need to quantify flood frequencies leads to a requirement for continuous modeling.

The Rocky Branch watershed has been previously divided into nine subwatersheds averaging a little less than 300 acres each. In order to model the Rocky Branch Watershed, the SWMM model was developed with 60 subcatchments ranging in size from 6.9 to 75.1 acres, with an average size of 44.2 acres. The subcatchments were created by further subdividing the subwatersheds based on topography and the storm drain system network. Available data from various sources, such as digital maps of impervious surfaces and the urban storm drain system, were incorporated in the model. The SWMM model layout is shown in **Figure 4.3**.

**Figure 4.3 SWMM Model Layout**





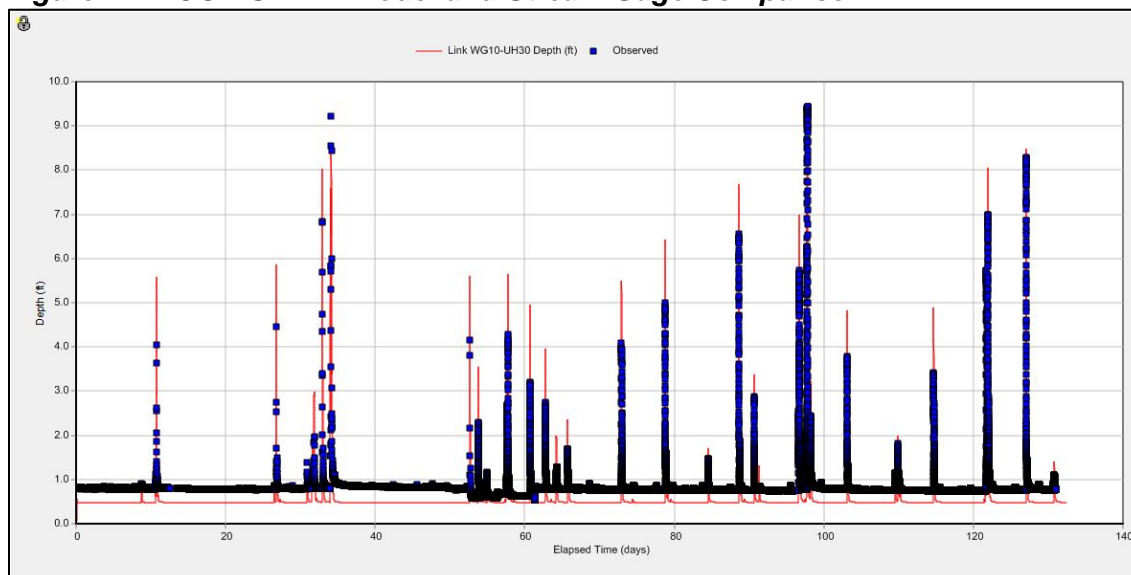
Spatially distributed rainfall-runoff modeling was conducted for the basin to quantify flood magnitudes and frequencies in different parts of the basin. The model was calibrated using the latest stream-flow data. Surface runoff was estimated using 5 gages at various points in the watershed. 15-minute or 5-minute rainfall data from a rain gage in close proximity to the subcatchment was used as the source of precipitation. Each subcatchment was assigned a specific rain gage. The rain gage locations and subcatchment boundaries are shown in **Figure 4.3**.

Percent Impervious cover for modeling was taken from a GIS layer obtained from the City of Columbia. For hydrologic modeling, infiltration is modeled explicitly as part of runoff calculations. The most recent soils data available from the United States Department of Agriculture (USDA) was used to determine the soils present in each subcatchment and the infiltration and run-off characteristics of the subcatchment (USDA NRCS, 2016).

Storm drain maps and data were used to model large pipes and culverts as necessary. Trunk lines had to be included in the SWMM model in order to provide connectivity for all subcatchments. Stream cross-sections from the 2015 HEC-RAS model developed for the Draft FIS were used in SWMM where available on Rocky Branch to provide better calculations of flows for input to the hydraulic model. Other channel cross sections were surveyed or estimated from the stream cruises performed as a part of this project. In some cases, maps were obtained from the City of Columbia to provide further detail and clarity in areas where GIS mapping was insufficient. Site visits were also performed to check the accuracy of the model geometry.

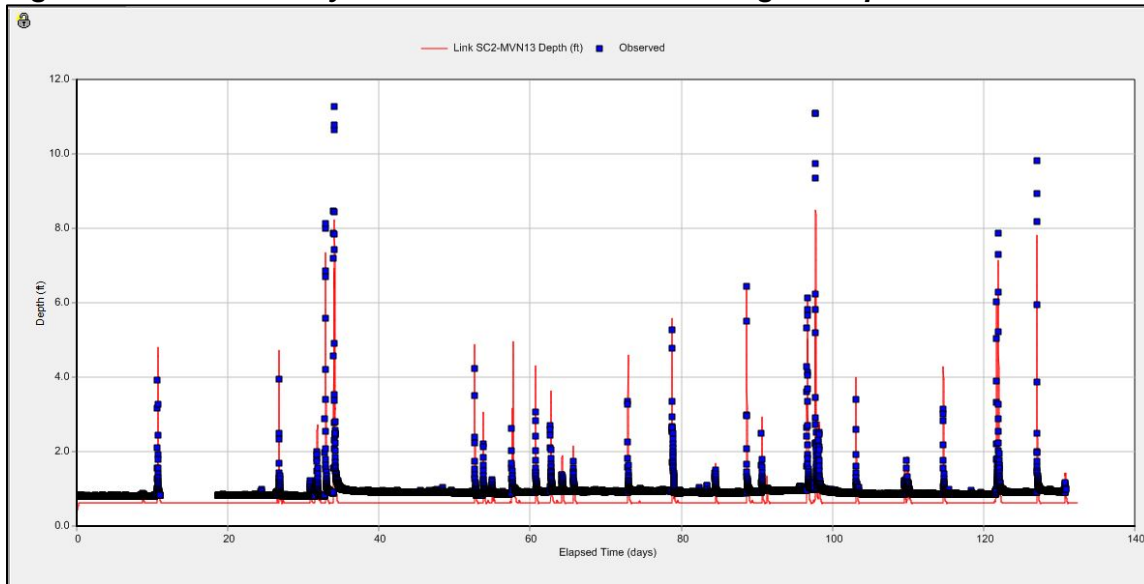
Stream gage data at three sites was used to help calibrate the SWMM Model. For each event modeled, water surface elevations were compared to gage data. The model subcatchment parameters were then adjusted so that the modeled depths attain a reasonable approximation to the elevations measured at the gage. Comparisons with historic events were also made to determine if the model represents roadway overtopping or flooding that actually occurred. The results of the SWMM Model compared to Stream Gages ROCA at Maxcy Gregg Park, the United States Geologic Survey (USGS) Whaley Street Gage, and Stream Gage ROCB are shown below (**Figures 4.4 to 4.6**).

**Figure 4.4 ROCA SWMM Model and Stream Gage Comparison**

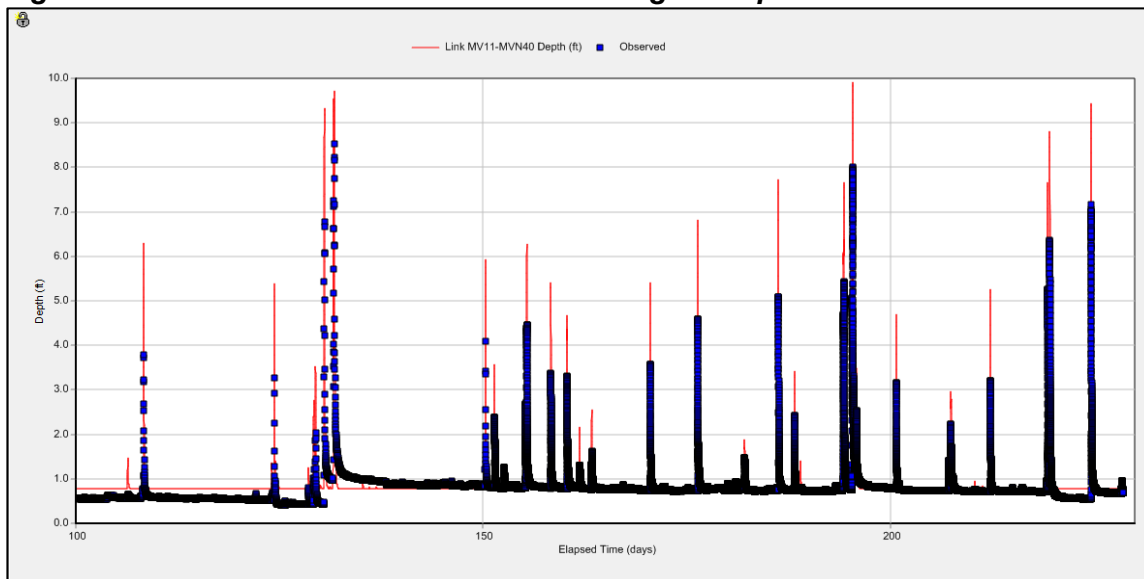




**Figure 4.5 USGS Whaley SWMM Model and Stream Gage Comparison**



**Figure 4.6 ROCB SWMM Model and Stream Gage Comparison**



The SWMM Model produced the most accurate peaks at the Rocky A (ROCA) gage. Further downstream, at the USGS Whaley Street Gage, the peaks from SWMM were lower than those from some higher intensity storms. At the Rocky B (ROCB) gage SWMM produced consistently higher peaks than what was measured. However, this was less important to the calibration because the purpose of the SWMM Model was not to predict peaks, but rather to estimate flows for use in HEC-RAS.

Once the SWMM Model calibration was complete, the 2, 10, 25, 50, 100 and 500-year design storms were run through the model, each as a single event. This produced flows along Rocky Branch that could then be input into the HEC-RAS model at the specified river stations.

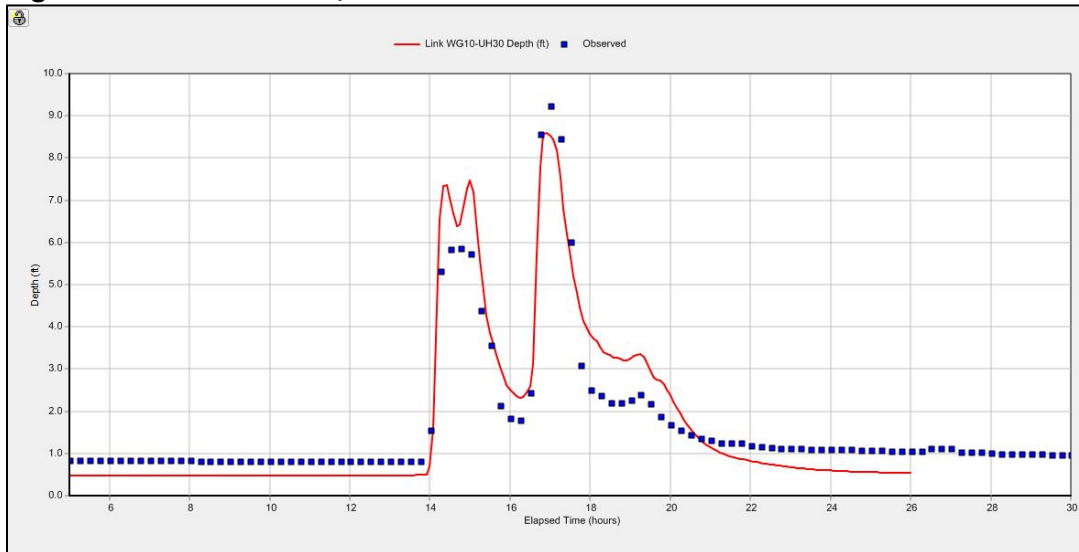


### 4.3.2 Gage Results in HEC-RAS

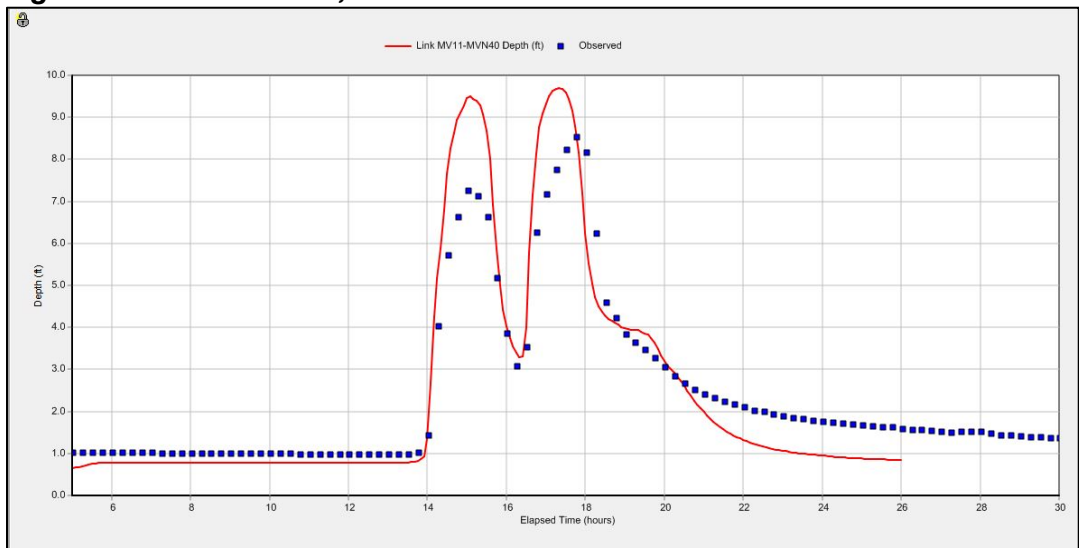
A storm that occurred on June 3, 2015 was also run in the HEC-RAS model, in order to check its output. This storm produced approximately 4.24 inches of rain in 6 hours, similar to the 25 year 6 hour National Oceanic and Atmospheric Administration (NOAA) event for this area. The results for this storm from SWMM are shown below at stream gages ROCA (**Figure 4.7**) and ROCB (**Figure 4.8**).

For the June 3, 2015 storm in HEC-RAS, the peak for the USGS Whaley St. Gage and the ROCB Gage are 180.19 and 142.14 feet North American Vertical Datum (NAVD), giving water depths of 12.79 and 10.87 feet when subtracted from the channel invert. The gages read from the permanent pool, so for the ROCB Gage, at Olympia Avenue where Rocky Branch has a permanent pool measured at approximately 133.6 feet NAVD deep, the HEC-RAS water surface corresponds to 8.5 feet of gage depth. This aligns well with the gage readings of 11.5 and 8.5 feet for these locations.

**Figure 4.7 ROCA June 3, 2015 Storm**



**Figure 4.8 ROCB June 3, 2015 Storm**





### 4.3.3 Flow Results

HEC-RAS flows from the existing 2015 Draft FIS are below (**Table 4.2**). HEC-RAS River Station (RS) locations are shown in Figure 4.9.

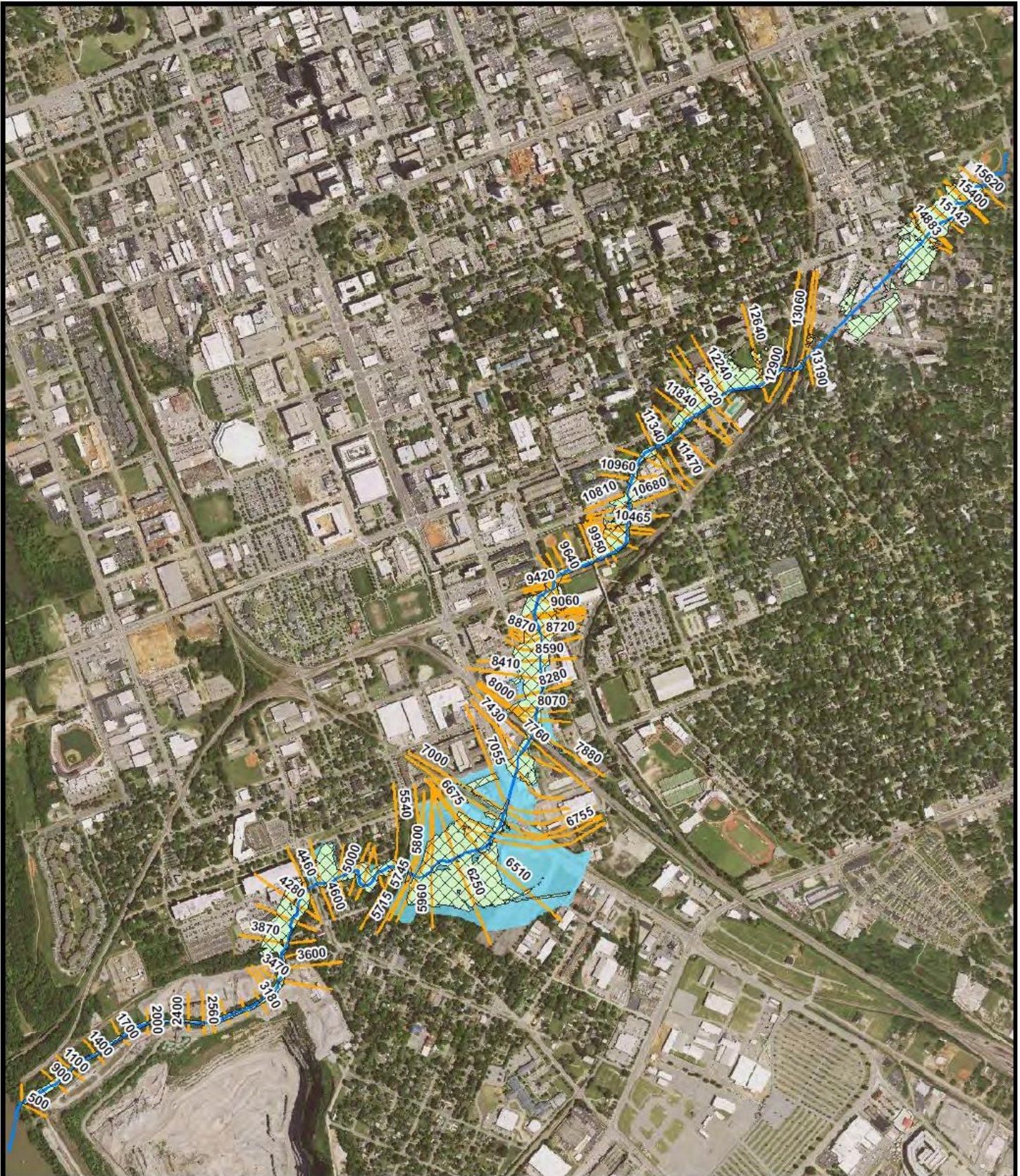
**Table 4.2 2015 FIS Existing HEC-RAS Flows**

River Station (RS)	2-year (CFS)	10-year (CFS)	25-year (CFS)	50-year (CFS)	100-year (CFS)	500-year (CFS)
15620	280	563	725	859	991	4,149
14883	964	1,590	1,832	1,927	2,043	4,149
13190	964	1,530	2,021	2,443	2,908	4,149
12640	964	1,712	2,139	2,416	2,689	4,602
11200	964	1,747	2,183	2,467	2,739	4,532
9640	964	1,726	2,198	2,486	2,763	4,437
6755	964	1,681	1,793	1,910	1,986	3,809
6250	964	2,200	2,610	2,796	2,927	4,151
2000	964	2,204	2,607	2,800	2,935	4,139

See **Table 4.3** below for flows developed from the updated SWMM Analysis and used in the updated HEC-RAS Model. Also included in this table are the flows from the June 3, 2015 storm, which created flows similar to the 2-year 24-hour event. The full flows calculated for the culverts in Five Points were added at the upper bounding cross-section (RS 14883), even though they would not develop until the mid-point of the culverts due to other flow inputs.

**Table 4.3 2016 SWMM Flows**

River Station (RS)	2-year (CFS)	10-year (CFS)	25-year (CFS)	50-year (CFS)	100-year (CFS)	500-year (CFS)	3-Jun 2015 Storm (CFS)
15620	532	662	679	704	7,52	7,53	590
14883	1,196	1,307	1,308	1,333	1,360	1,403	1,217
13190	1,367	1,373	1,379	1,375	1,373	1,378	1,373
12640	1,317	1,358	1,385	1,411	1,434	1,490	1,316
11200	1,592	1,834	2,007	2,143	2,291	2,667	1,565
9640	1,914	2,464	2,567	2,747	2,997	3,594	1,848
6755	2,035	2,837	3,210	3,568	3,993	5,014	1,984
6250	2,007	2,650	2,987	3,252	3,565	4,479	1,972
2000	1,668	1,905	2,033	2,134	2,234	2,462	1,610



**Figure 4.9: 10-Year HEC-RAS Results**

- 10-year Existing Floodplain
  - 10-year Culvert Scenario 1 Floodplain
  - 10-year Culvert Scenario 2 Floodplain
- Rocky Branch
  - HEC-RAS Cross-Sections

N

0 337.5 675 1,350 Feet

Image Source: USDA NAIP, 2015



#### 4.3.4 Water Surface Profile Evaluation

The Hydraulic Analysis to determine water surface elevations (WSEs) for this study was done by taking the flows generated from SWMM and using them as input to HEC-RAS models. The HEC-RAS models from the 2007 PB Americas Study, the 2012 AMEC Study and the 2015 Draft FIS were all reviewed for this analysis. The 2015 HEC-RAS model used the most recent survey, and represented the most accurate channel conditions; however, it only extended up Rocky Branch to the area just downstream of the Five Points culverts. In order to model the entire study area, this model was combined with the 2012 AMEC model in order to include the upper portions of Rocky Branch extending to the top of MLK Park. This new “combined” HEC-RAS model was then field verified as a part of this study. Once the updated model geometries were compiled, channel crossings and roughness values were evaluated in the field to ensure the model depicts watershed conditions as accurately as possible.

Building on current analysis and recommendations from previous studies, the proposed improvements focus primarily on new cross-section recommendations at crossings that play a large role in controlling water surface profiles. The hydrologic flow data in the models has been updated to reflect the data developed from the spatially-distributed rainfall-runoff relationships, updated stormwater network, and the streamflow calibrations from available gage data. These updated models can then be used to show the extent of areas of flooding concern in conjunction with the mapped FEMA floodplains.

In 2007, PB Americas studied the culvert configurations on Rocky Branch in detail. Recommendations for upgrading the culverts along Rocky Branch were made under this study. Some of these recommendations for culvert replacements were included as proposed modifications and modeled as a part of this project. New recommendations have also been proposed in the upper areas of Rocky Branch. Two scenarios have been proposed below (**Tables 4.4 and 4.5**), building on the 2007 PB Americas Study. Scenario 1, where culvert replacements have been made up to the railroad crossing below Whaley Street, and Scenario 2, where culvert replacements have been made up to Catawba Street. These proposed culvert replacement scenarios both include the railroad crossing near Olympia Avenue, which was not included in the 2007 PB Americas Study.

For several culvert locations, providing a beveled culvert top edge will improve conveyance. The bevel is proportioned based on the culvert barrel or face dimension and operates by decreasing the flow contraction at the inlet. Adding bevels to a conventional culvert design with a square-edged inlet increases culvert capacity by 5 to 20 percent. The higher increase results from comparing a bevel-edged inlet with a square-edged inlet at high headwaters. The lower increase is the result of comparing inlets with bevels with structures having wingwalls of 30 to 45 degrees.



**Table 4.4 Culvert Analysis Scenario 1: Olympia Avenue, Olympia Railroad, Bluff Road and Southern Railroad 02 Culvert Replacements**

Crossing Type	River Station - Name	Proposed Modification	Existing WSE (Ft)		Proposed WSE (Ft)	
			10-year	100-year	10-year	100-year
Culvert(s)	14883 – Five Points Culvert	Beveled culvert top edge	223.20	223.28	223.18	223.86
Culvert(s)	13190 – Five Points Culvert		211.35	211.40	211.35	211.40
Railroad Bridge	12900 – Southern Railroad 04		209.18	209.28	209.18	209.28
Culvert	11470 – Pickens St	Beveled culvert top edge	205.01	206.21	204.96	206.20
Culvert	10810 – Wheat St	Beveled culvert top edge	202.04	202.52	201.95	202.51
Railroad Bridge	9490 – Southern Railroad 03		192.56	192.90	192.56	192.90
Culvert	9420 – Sumter St		192.31	192.59	192.31	192.59
Culvert	9240 – USC Building	Beveled culvert top edge	188.61	189.02	188.61	189.02
Culvert Dual 8X6	8820 – Catawba St	Beveled culvert top edge	186.56	185.97	186.54	185.97
Culvert Dual 8X5.5	8280 – Whaley St	Beveled culvert top edge	181.89	183.01	178.67	179.05
Culvert 13X11 Arch	7880 – Southern Railroad 02	Dual 12 X 12 Box Culverts	181.87	182.98	178.40	179.55
Culvert Dual 10X8	7430 – Assembly St	Beveled culvert top edge	171.77	173.00	170.75	171.01
Railroad Bridge	7000 – Southern Railroad 01		171.63	173.00	164.69	165.57
Bridge	6755 - Dreyfus Rd	Beveled culvert top edge	171.40	172.81	161.72	162.19
Culvert 14X12 Arch	5800 – Bluff Road	16 X 14 Box Culvert	171.39	172.80	159.79	161.34
Culvert 14X11.5 Arch	5715 – Olympia Railroad	Dual 10 X 12 Box Culverts	171.37	172.76	157.65	160.90
Culvert 12X8.5 Arch	4600 – Olympia Ave	Dual 10 X 10 Box Culverts	148.48	149.19	147.10	148.40
Culvert	2650 – Quarry CMP Arch		135.77	137.26	135.77	137.26



**Table 4.5 Culvert Analysis Scenario 2: Addition of Whaley and Catawba Culvert Replacements to Scenario 1**

Crossing Type	River Station - Name	Proposed Modification	Existing WSE (Ft)		Proposed WSE (Ft)	
			10-year	100-year	10-year	100-year
Culvert(s)	14883 – Five Points Culvert	Beveled culvert top edge	223.20	223.28	223.18	223.86
Culvert(s)	13190 – Five Points Culvert		211.35	211.40	211.35	211.40
Railroad Bridge	12900 – Southern Railroad 04		209.18	209.28	209.18	209.28
Culvert	11470 – Pickens St	Beveled culvert top edge	205.01	206.21	204.96	206.20
Culvert	10810 – Wheat St	Beveled culvert top edge	202.04	202.52	201.95	202.51
Railroad Bridge	9490 – Southern Railroad 03		192.56	192.90	192.56	192.90
Culvert	9420 – Sumter St		192.31	192.59	192.31	192.59
Culvert	9240 – USC Building	Beveled culvert top edge	188.61	189.02	188.61	189.02
Culvert Dual 8X6	8820 – Catawba St	Dual 20 X 6 Box Culverts	186.56	185.97	183.92	185.96
Culvert Dual 8X5.5	8280 – Whaley St	Dual 25X6 Box Culverts	181.87	182.97	178.64	179.71
Culvert 13X11 Arch	7880 – Southern Railroad 02	Dual 12 X 12 Box Culverts	181.87	182.98	178.40	179.55
Culvert Dual 10X8	7430 – Assembly St	Beveled culvert top edge	171.77	173.00	170.75	171.01
Railroad Bridge	7000 – Southern Railroad 01		171.63	173.00	164.69	165.57
Bridge	6755 - Dreyfus Rd	Beveled culvert top edge	171.40	172.81	161.72	162.19
Culvert 14X12 Arch	5800 – Bluff Road	Single 16 X 14 Box Culvert	171.39	172.80	159.79	161.34
Culvert 14X11.5 Arch	5715 – Olympia Railroad	Dual 10 X 12 Box Culverts	171.37	172.76	157.65	160.90
Culvert 12X8.5 Arch	4600 – Olympia Ave	Dual 10 X 10 Box Culverts	148.48	149.19	147.10	148.40
Culvert	2650 – Quarry CMP Arch		135.77	137.26	135.77	137.26

#### 4.3.5 Results from Culvert Analysis

Benefits from culvert replacements are diminished upstream of Assembly Street. This trend was also noted in the 2012 AMEC Study. The addition of the larger culverts at the Whaley and Catawba Street crossings only provide minimal improvements at those locations. **Table 4.6** below shows a comparison of the two scenarios from Catawba Street downstream.

The best locations for future culvert replacements appear to be at the Bluff Road, Olympia Railroad and Olympia Avenue crossings. Also note that the existing 100-year floodplain in the area near Dreyfus St is noted as 172 NAVD. The HEC-RAS model used in this study puts the 100-year WSE at 172.81 NAVD at this location.



**Table 4.6 Comparison of Culvert Analysis Scenarios**

RS - Location	Approx. Road Elev. (Ft)	2-Year WSE (Ft)			10-Year WSE (Ft)			100-Year WSE (Ft)		
		Ex.	Scenario 1	Scenario 2	Ex.	Scenario 1	Scenario 2	Ex.	Scenario 1	Scenario 2
		8820 – Catawba St	185.0	185.97	186.29	183.19	186.56	186.54	183.92	186.30
8280 – Whaley St	178.0	180.28	178.23	177.63	181.89	178.67	178.64	183.01	179.05	179.71
5800 – Bluff Rd	161.0	164.45	157.47	157.47	171.39	159.79	159.79	172.80	161.34	161.34
5715 – Olympia Railroad	N/A	164.28	155.13	155.13	171.37	157.65	157.65	172.76	160.90	160.90
4600 – Olympia Ave	149.0	147.82	144.46	144.46	148.48	147.10	147.10	149.19	148.40	148.40
2650 – Quarry CMP Arch	150.5	134.68	134.68	137.26	135.77	137.26	137.26	137.26	137.26	137.26

**4.3.6 Water Storage Analysis**

As a part of this study, the idea of using MLK Park above Five Points as a detention area was studied. In order to do this, it was modeled in SWMM as a 900 foot trapezoidal channel with an 80 foot width at the bottom, and was sized to store approximately 600,000 cubic feet of water. An invert of a 48 inch pipe was set at 220 feet, giving approximately six feet of storage capacity. This limits the outflow to about 200 CFS during the 2-year event, and almost detains the entire flow. The flow results from SWMM are included in **Table 4.7** below.

**Table 4.7 Comparison of 2016 SWMM Flows with MLK Detention Alternative**

RS	Existing 2-year (CFS)	Existing 10-year (CFS)	Proposed 2-year (CFS)	Proposed 10-year (CFS)
15620	532	662	964	1,057
14883	569	652	198	322
13190	1,367	1,373	555	1,308
12640	1,317	1,358	1,240	1,325
11200	1,592	1,834	1,538	1,778
9640	1,914	2,464	1,823	2,451
6755	2,035	2,837	1,974	2,777

As the water flows down Rocky Branch, other catchments add flows to the system diminishing the effect of the impoundment. However, there should be reductions in flooding in other areas due to the upstream detention and delay of peak along the Rocky Branch mainstem. This scenario nearly detains the 2-year event, and allows water further down Rocky Branch to drain out of the watershed, potentially improving downstream pinch points.

**4.3.7 Recommendations for Future Watershed Studies**

The SWMM model for this project has been developed to provide stream flow for HEC-RAS assessments of flooding problems in the Rocky Branch watershed. SWMM has capabilities that



have not been used in this project that could potentially be useful for future watershed analysis. SWMM models have been used to assess the effectiveness of stormwater detention throughout a watershed, showing where onsite peak flow reduction could lead to higher peaks in downstream channels. SWMM models are also useful for storm drain capacity analysis and analyzing the effectiveness of alternative improvements. The dynamic wave algorithm is particularly effective for analyzing complex improvements such as parallel relief drains, weirs, or other structures.

SWMM also has the capability of modeling pollutant loading; however, the input data needed for the buildup-washoff calculations is generally difficult to derive and simpler spreadsheet models are as effective for estimating benefits of changes in land use or improvements to treat or reduce loads.

Increasing the number of subwatersheds and decreasing their size in the SWMM Model will provide better resolution for identifying and prioritizing problem areas and performing capacity analysis; however, this requires a higher cost in complexity and resources needed. In order to increase the accuracy and create a better overall watershed model additional mapping and surveying is needed. The Mill Villages North, Rosewood and Fair Grounds areas will require further mapping of pipe and ditch conveyance systems in order to be able to better delineate additional subcatchment areas. Further subdivision of catchments will help to provide increased accuracy of flows and peaks in the area of the model around these areas.

The SWMM model could be used to study the use of MLK park to provide some storage capacity to reduce peaks, and shift the timing of the flows from the upper portions of the watershed so that they do not all peak at once. There are very few areas for detention of this sort until further down the main watercourse near the Bluff Road area where their usefulness is diminished. SWMM modeling could determine where in the watershed detention becomes ineffective because of this effect.

Mapping in the area around the intersection of Millwood Avenue and King Street is incomplete, and no maps provided by the City of Columbia had the entire pipe network represented in this area. There is a 24 inch reinforced concrete pipe (RCP) in Millwood Avenue that is believed to tie into a 54 inch RCP at the end of House Street, but this could not be determined with either the maps provided or field visits. Although it is not believed this will affect overall flows out of the SWMM Model, it will be necessary for more in depth watershed studies. Most of the pipe network did not have invert data associated with it. Attaining inverts at key locations of trunk lines will also help to improve the accuracy of the model for more in depth watershed studies.

The City of Columbia should consider adding a gage location upstream of the current Olympia Avenue location, at the Dreyfus Road crossing. The Olympia Avenue, CSX Railroad and Bluff Road crossings are some of the most constrained culvert crossings in the Rocky Branch watershed. A gage location above this area, at the more adequately sized Dreyfus Road culvert crossing would be a better location for calibration of models and prediction of flows.



## 5.0 Subwatershed Ranking

Subwatershed runoff rankings were developed for the eleven subwatersheds in the Rocky Branch Watershed. These rankings are based in part on a typical 2-year storm event modeled in SWMM for existing conditions. Each subwatershed was ranked on percent imperviousness, peak runoff per acre, total volume of runoff, and volume of runoff per acre to produce a total ranking where the lower the total, the lower the integrity of existing conditions for the subwatershed (**Table 5.1**). Based on the 2-year event, the least impacted subwatershed for runoff was the Outlet with an overall rank of 11 and the most impacted subwatershed is Gregg Street with an overall rank of 1. The results of the Cumulative Ranking are shown in **Figure 5.1**.

**Table 5.1 Subwatershed Runoff Rankings (2-year Storm Event)**

Sub-watershed	Acres	Impervious Cover		Peak Discharge		Total Runoff		Unit Runoff		Cumulative Ranking	
		%	Rank	CFS/ac	Rank	MIL gal	Rank	Cubic Feet/ac	Rank	Total Score	Overall Rank
GS	404	70%	1	4.7	5	31.4	1	10,392	1	8	<b>1</b>
USC	173	53%	4	5.9	1	11.2	5	8,680	3	13	<b>2</b>
MV-A	175	54%	2	5.7	3	11.4	4	8,675	4	13	<b>3</b>
UH	125	54%	3	5.9	2	8.6	8	9,224	2	15	<b>4</b>
MLK	503	47%	5	5.1	4	25.7	2	6,828	5	16	<b>5</b>
DB	192	47%	6	3.7	9	9.1	6	6,353	6	27	<b>6</b>
RW	489	41%	8	4	8	20.1	3	5,489	8	27	<b>7</b>
HRH	221	40%	9	4.2	7	8.9	7	5,387	9	32	<b>8</b>
FG	171	46%	7	2.8	11	7.7	9	6,029	7	34	<b>9</b>
MV-B	154	40%	10	4.3	6	6.1	10	5,283	10	36	<b>10</b>
OT	63	11%	11	3.3	10	1.1	11	2,387	11	43	<b>11</b>

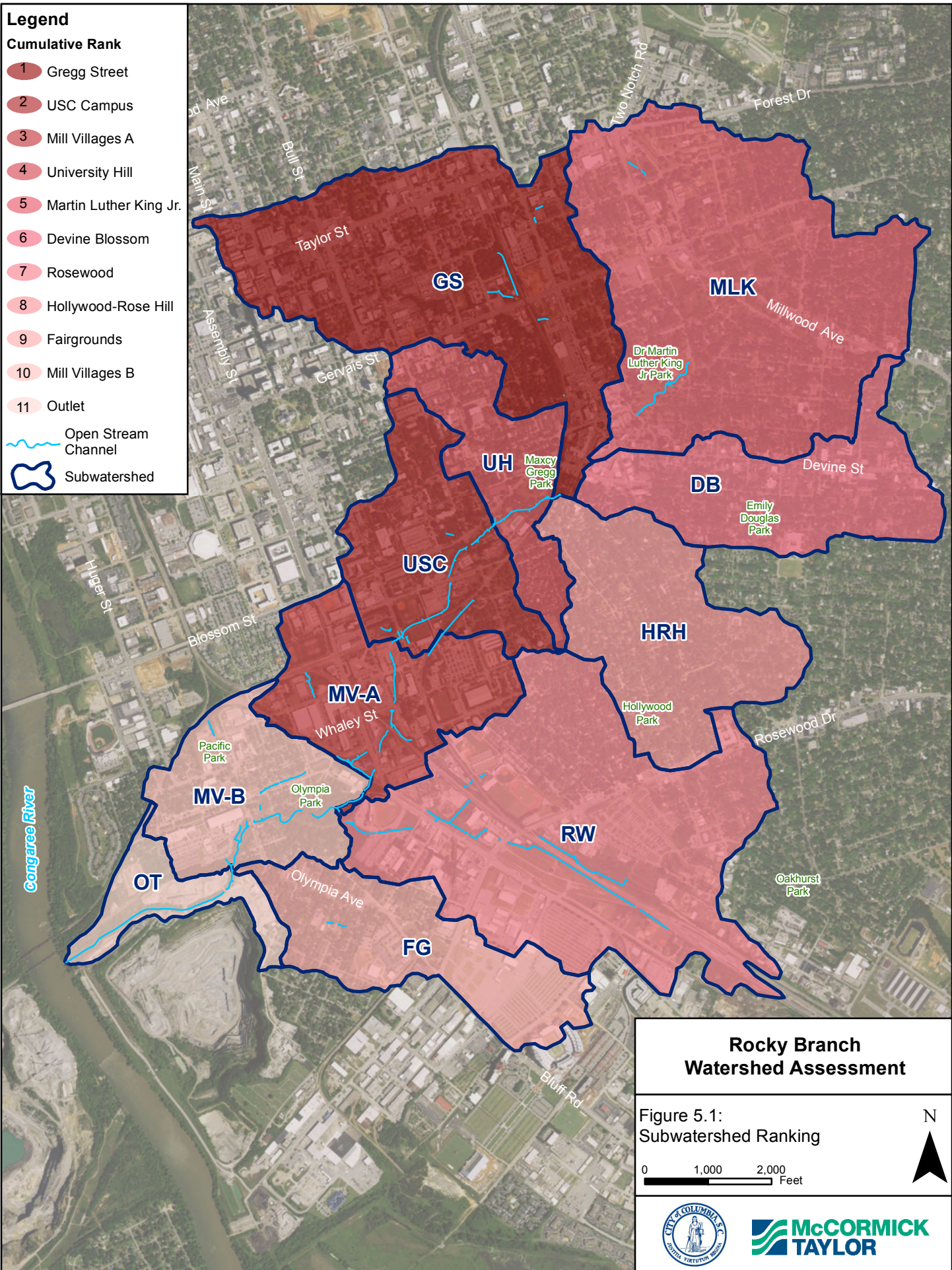
**Legend**

**Cumulative Rank**

- 1 Gregg Street
- 2 USC Campus
- 3 Mill Villages A
- 4 University Hill
- 5 Martin Luther King Jr.
- 6 Devine Blossom
- 7 Rosewood
- 8 Hollywood-Rose Hill
- 9 Fairgrounds
- 10 Mill Villages B
- 11 Outlet

Open Stream Channel

Subwatershed
















## 6.0 Detailed Subwatershed Assessment Results

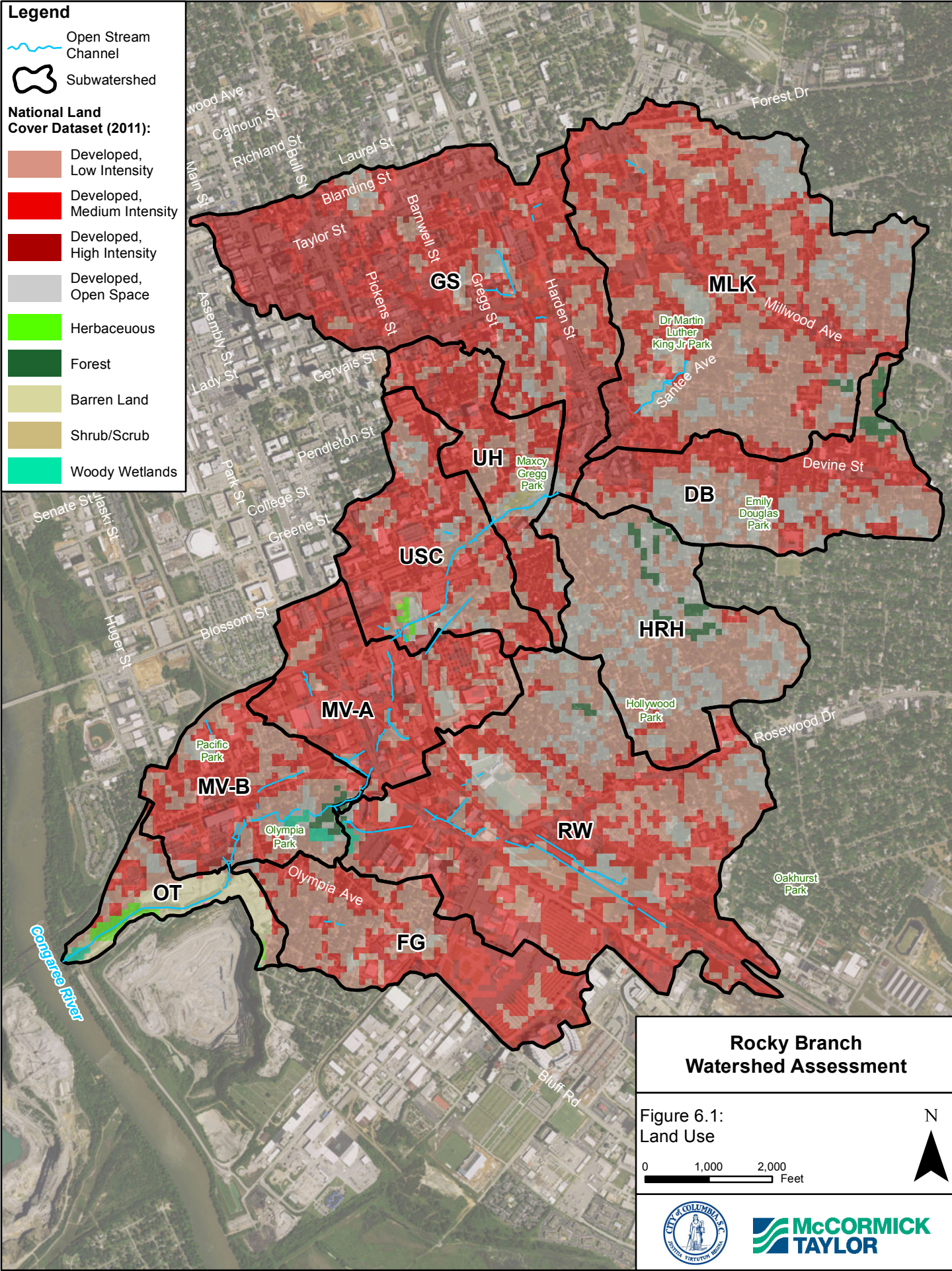
The results of the existing conditions and preliminary restoration opportunities assessments are presented in this section. Each assessment is broken down by subwatershed and includes a general description of the location, land use, imperviousness and soils within each subwatershed. Also included in each assessment is a discussion on existing channel conditions and a SWM assessment of each subwatershed. Potential restoration opportunities have been identified based on the assessment of existing conditions. Each assessment contains descriptive graphics including: existing conditions, soils and restoration opportunities. **Figure 6.1** and **Table 6.1** highlight land use data for the entire subwatershed and are referenced in each subwatershed assessment.

**Legend**

-  Open Stream Channel
-  Subwatershed

**National Land Cover Dataset (2011):**

-  Developed, Low Intensity
-  Developed, Medium Intensity
-  Developed, High Intensity
-  Developed, Open Space
-  Herbaceous
-  Forest
-  Barren Land
-  Shrub/Scrub
-  Woody Wetlands



**Rocky Branch  
Watershed Assessment**

Figure 6.1:  
Land Use

0 1,000 2,000  
Feet





Table 6.1 Subwatershed Land Use

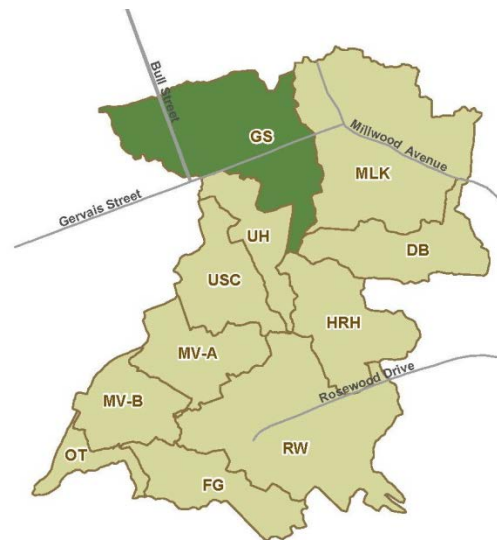
Land Use	OT		FG		MV-B		RW		MV-A		USC		UH		HRH		DB		GS		MLK		Total		
	Acres	%	Acres	%	Acres	%	Acres	%	Acres	%	Acres	%	Acres	%	Acres	%	Acres	%	Acres	%	Acres	%	Acres	%	
Developed, Low Intensity	15.99	25%	65.02	38%	52.46	34%	167.56	34%	27.90	16%	50.19	29%	35.13	28%	127.78	58%	55.40	34%	50.47	12%	231.36	46%	879.26	33%	
Developed, Medium Intensity	8.50	13%	70.14	41%	67.13	44%	194.71	40%	100.67	58%	95.38	55%	69.29	55%	8.82	4%	59.28	36%	160.99	40%	172.26	34%	1007.16	38%	
Developed, High Intensity	1.91	3%	32.37	19%	16.27	11%	66.49	14%	42.93	25%	14.51	8%	9.32	7%	1.55	1%	15.44	9%	180.05	45%	39.07	8%	419.90	16%	
Developed, Open Space	2.48	4%	3.16	2%	10.74	7%	57.04	12%	3.17	2%	11.05	6%	8.82	7%	73.13	33%	28.94	18%	12.26	3%	59.36	12%	270.16	10%	
Herbaceous	5.81	9%									2.00	1%											7.81	0%	
Forest					3.65	2%	1.55	0%	0.37	0%					9.33	4%	5.71	3%				1.11	0%	21.72	1%
Shrub/Scrub													2.67	2%									2.67	0%	
Woody Wetlands	1.75	3%			3.89	3%	1.22	0%															6.86	0%	
Barren Land	26.70	42%	0.26	0%	0.05	0%																	27.01	1%	
Cultivated Crops	0.09	0%																					0.09	0%	
Open Water	0.03	0%																					0.03	0%	
<b>Total</b>	<b>63.26</b>	<b>100%</b>	<b>170.94</b>	<b>100%</b>	<b>154.19</b>	<b>100%</b>	<b>488.56</b>	<b>100%</b>	<b>175.03</b>	<b>100%</b>	<b>173.14</b>	<b>100%</b>	<b>125.23</b>	<b>100%</b>	<b>220.62</b>	<b>100%</b>	<b>164.78</b>	<b>100%</b>	<b>403.76</b>	<b>100%</b>	<b>503.16</b>	<b>100%</b>	<b>2642.68</b>	<b>100%</b>	

## 6.1 Gregg Street (GS) Subwatershed

### Introduction

#### Setting:

- The Gregg Street (GS) subwatershed is the northwestern most subwatershed within the Rocky Branch watershed.
- The subwatershed's southernmost/downstream end falls between the UH and DB subwatersheds, north approximately 1 mile to Taylor Street, and west to approximately 200 feet east of Assembly Street.
- 404 acres or 0.63 square miles in drainage area
- Contains 0.34 miles of open stream channel, and 9.62 miles of mapped storm drain/pipe
- Dominant land use designations (**Figure 6.1, Table 6.1**):
  - Developed, High Intensity: 45%
  - Developed, Medium Intensity: 40%
- Impervious surface cover: 70%



**Figure 6.2 Gregg Street Subwatershed**

**Soils:** Approximate soil type percentages within GS subwatershed include (refer to **Section 3.4** for soil descriptions and **Figure 6.3** for soil distributions):

- Urban land (Ur): 80%
- Orangeburg-Urban land complex, 2 to 6% slopes (OgB): 19%
- Orangeburg-Urban land complex, 6 to 15% slopes (OgD): 1%




#### Overview:

With the densely urbanized Five Point neighborhood within the southern limits, and the heart of Downtown Columbia within the northwestern limits, GS is highly developed. The majority of the Five Points neighborhood is within this subwatershed and contains large commercial buildings with associated parking facilities. Other than street trees and other localized residential/commercial plantings, Five Points is almost completely impermeable. The portion of downtown Columbia within the subwatershed is also extensively urbanized, but contains a few small parks and mature street plantings.

### Existing Conditions

**Figure 6.4** highlights existing conditions that were either captured during the stream cruising effort or developed using GIS data.

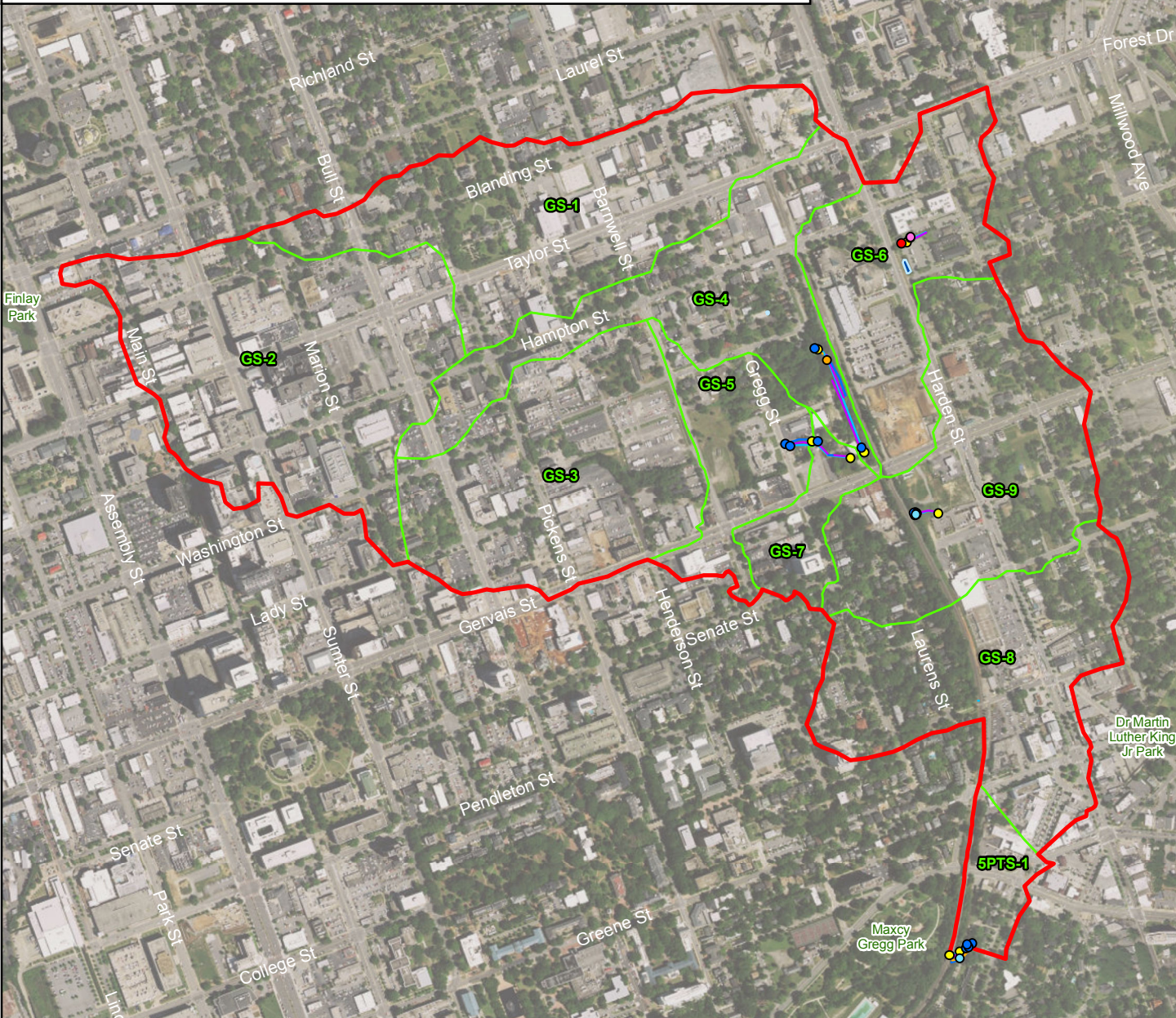
**Legend**

-  Open Stream Channel
-  Soils
-  Subwatershed



**Legend**

- Trash Dumping
- Pipe Outfall
- Near Stream Construction
- Possible Fish Barrier
- Exposed Pipe
- Bedrock
- Unmanaged Runoff
- Unusual Condition
- ~ Open Stream Channel
- Erosion Site
- Channel Alteration
- Inadequate Forest Buffer
- SWM Facility
- SWMM Subcatchment
- Subwatershed





Existing Condition	Count
Exposed Pipes	5
Pipe Outfalls	13
Unmanaged Runoff	1
Unusual Condition	8
Trash Dumping	1
Possible Fish Barrier	0
Linear Feet	
Erosion Site	204
Channel Alteration	625
Inadequate Forest Buffer	2,580

**Rocky Branch  
Watershed Assessment**

Figure 6.4:  
Gregg St Subwatershed  
Existing Conditions

N  
▲

0 500 1,000  
Feet

### Channel Conditions:

The northern most section of open stream channel lies between two parking lots southeast the intersection of Harden and Hampton Street. The stream emerges from an outfall, flows for 25 feet and then is piped underneath the southern parking lot. A 110-foot long dry swale converges from the east with the channel. There is some herbaceous vegetation in the channel and a large amount of residential trash has accumulated around the northern outfall.



The most significant length of open channel is located southeast of the corner of Washington and Cherokee Street. Flow originates from a 72-inch reinforced concrete pipe (RCP) outfall. The upstream extent exhibits evidence of expansion scour adjacent to the pipe outfall and has resulted in a 10-foot high, eroded right bank. Recent slope repairs were made to the left bank along an approximately 18-foot tall railroad embankment. Riprap placed along the steep railroad embankment has slumped into the channel bed. The right bank was also stabilized with riprap at this

location. Channel substrate is locked in with the prevalence of masonry brick and concrete functioning as bed material. At the downstream extent, the channel enters a large pipe just north of Gervais Street.

To the southwest of the stream previously described is an open channel stream segment that emerges from an arched brick outfall at Gregg Street. Both of the 3 to 4-foot tall banks are stabilized with riprap at the upstream limit. The bed substrate is primarily sand and gravel with point bars present in the bends. The channel flows through a box culvert at a commercial driveway and is open again for a short segment before entering a concrete pipe conveying flow underneath Gervais Street.

Another small segment of open stream channel is located south of the intersection of Gervais and Laurens Street. This stream segment receives all flow from previously described open channel. The stream originates from a stone block masonry arch emerging from underneath the railroad. Two 36-inch reinforced concrete pipes enter the channel from the left bank. A significant headcut has formed behind the pipes as a result of overland flow and concentrated runoff from Laurens Street and a parking lot adjacent to the stream. Two sanitary lines are exposed in the stream bed and one sanitary line runs along the right bank from a manhole stack into the railroad culvert. The 3 to 4-foot tall banks are vegetated with herbaceous cover and are stable. The channel substrate consists primarily of cobble, with some concrete and rubble from the banks slumped into the bed. The stream then flows into twin concrete pipes flanked by stone walls on either side.





The most southern and downstream segment of open channel in the GS subwatershed is located between Maxcy Gregg Park and Saluda Avenue. The upstream limit of the longest segment of open mainstem channel in Rocky Branch, the contributing drainage area encompasses the GS, MLK, and DB subwatersheds. The stream emerges from a concrete arched culvert and an adjacent concrete box culvert, both originating from Five Points. The segment ends at the subwatershed boundary 120 feet downstream, where it passes under a dilapidated railroad trestle and enters

Maxcy Gregg Park. This segment of open channel is the recipient of large volumes of concentrated unmanaged piped runoff from the Five Points neighborhood, which is likely a contributor to the poor water quality and bank instability. Just downstream of the culvert is a large scour pool with cloudy, green water. The left bank is approximately 20-feet high and highly unstable, threatening infrastructure and posing a public safety concern. A manhole stack is exposed in the left bank. Vegetation is thick and chaotic with fallen growth, a competing mid-story, and vines climbing established trees and encompassing portions of the ground cover. A large depositional sand bar defines the right bank up to the railroad embankment. The awkward channel alignment relative to the railroad embankment puts further stress upon the trestle crossing. The city has recently purchased several properties adjacent to this reach (543-545, 547-549, and 601-603 Saluda Avenue) and is planning on using the property to access this highly impaired reach for restoration work.

### *Ecology*

Stream habitat quality is generally poor within the GS subwatershed. Lack of riparian buffer and bank vegetation, sedimentation, bank instability, excessive channel alteration and poor epifaunal substrate/available cover are common impairments throughout the scattered open channel segments. The least degraded habitat within the subwatershed was observed in the small segment of open channel at Gervais and Laurens Street; suboptimal vegetative protection, bank stability, epifaunal substrate/available cover and decreased sedimentation resulted in a fair score (120) for this reach. There were several areas of extremely poor water quality, mainly near the outfall at Washington and Cherokee Street and in the scour pool downstream of Five Points on the Rocky Branch Mainstem. Blue-green, cloudy water was observed in both areas.

Approximately 80% of the open channel network in the GS subwatershed has less than a 35-foot wide riparian buffer. The only significant area of vegetation is a small forested parcel on the right at the upstream end of the reach at Washington and Cherokee Street. The majority of the other stream segments have small trees, shrubs, and herbaceous vegetation on the banks, but little to no riparian buffer.



---

**Constraints:**

- Property Ownership:
  - Overall GS open channel:
    - Public: 37%
    - Private: 63%
  - Within 50 foot wide open channel buffer:
    - Public: 5%
    - Private: 95%
- Mapped Drainage Network:
  - Drain Pipe: 97%
  - Open Stream Channel: 3%
- One longitudinal channel interruption
- Channel encroachments: railroad, parking lots, and commercial buildings

**SWM Assessment:**

*Facilities*

One stormwater management (SWM) facility was mapped within the GS subwatershed. This fenced BMP receives stormwater runoff from the large First Calvary Baptist Church parking lot.

*Outfalls*

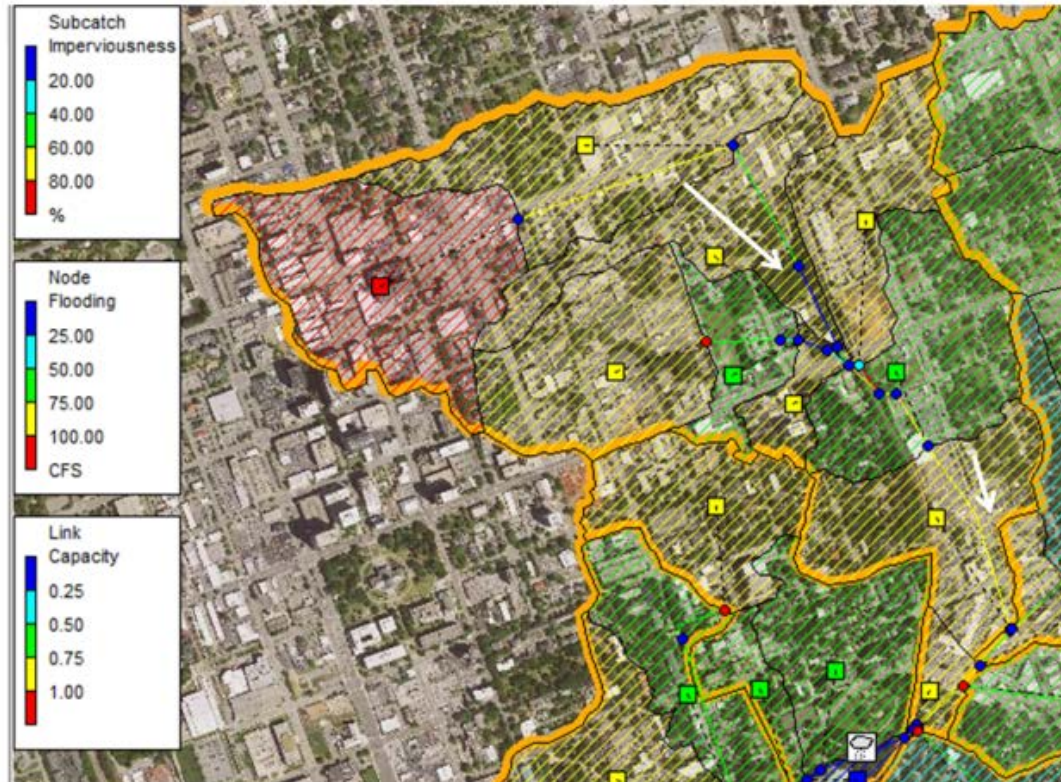
A total of 16 outfalls were identified within the GS subwatershed, five of which were noted to be in severe condition and three were in very severe condition. The outfall southeast of the corner of Gregg and Cherokee Street is experiencing expansion scour in the downstream channel and the water is a cloudy blue green color, indicative of a possible sewage leak. The outfall emerging from underneath the railroad embankment at the southern end of Laurens Street was also identified as being in very severe condition; the embankment is slumping behind the headwall and a sanitary line runs parallel within the pipe, restricting capacity and at risk for trapping debris. The third outfall in very severe condition is upstream of the northern end of Maxcy Gregg Park, west of Saluda Avenue. This outfall, along with two large concrete outfalls in severe condition, discharge into a large scour pool filled with cloudy blue green water. This area receives concentrated flow piped from the highly impervious Five Points neighborhood. The severe rating of the outfalls in this segment is based on the quality of the water discharged and the severe erosion of the nearby banks.

*SWMM*

The GS subwatershed is one of three that drains into the Five Points area of convergence. Based on the SWMM modeling for the GS subwatershed, it is estimated to produce 4.7 peak cfs/acre during a 2-year storm event. This amount is the fifth highest within the watershed. The total quantity of runoff predicted during a 2-year storm event is 31.39 million gallons, which is far and away the highest amount within the Rocky Branch watershed and well above the average of 12.8 million gallons. The GS subwatershed also has the highest runoff per area at 10,392 cubic feet/acre. This high runoff volume (22% of the total watershed volume for a 2-year storm) is in

part attributed to the subwatershed being the third largest at 404 acres, and having the highest impervious surface percentage at 70%. The GS subwatershed received the highest overall subwatershed runoff ranking within the Rocky Branch Watershed based on a combined scoring, indicating that it has a large influence on the timing and quantity of runoff in the watershed.

**Figure 6.5 GS SWMM Model**



The GS subwatershed was modeled as 10 subcatchments in SWMM. These subcatchments all ultimately drain to dual 72 inch RCPs, which connect underground to the culverts in the Five Points area. The flows from the GS subwatershed converging here cause frequent flash flooding in this area during moderate rain events. The SWMM Model shows this line is at almost 80% capacity during a 2-year event where it ties into these culverts, and indicates flooding is initiated in several areas of the subwatershed for this frequency of event.

**Total Subwatershed Runoff Ranking: 1**



---








## **Restoration Opportunities**

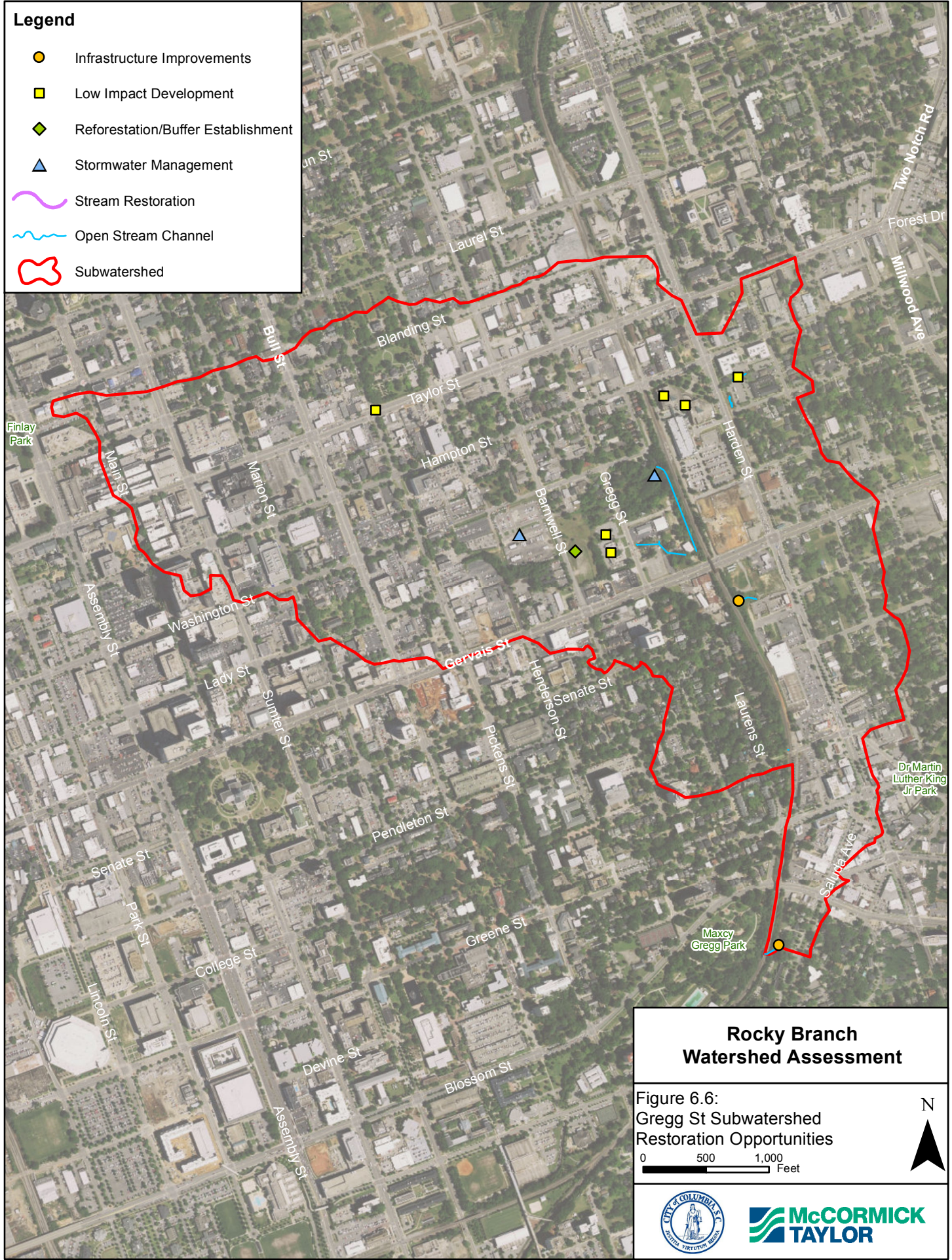
The following projects or similar improvements may be considered to address conditions identified in the GS subwatershed. These projects are included in **Figure 6.6**.

### **Recommended Improvements:**

- Culverts extending underneath of Five Points should be inspected for any blockages as well as for structural integrity.
- Opportunities for infiltration and storage should be investigated here to reduce peaks downstream.
  - Install a pocket wetland or pond behind the First Calvary Baptist Church at Harden Street.
  - Install an underground quantity storage with infiltration or bioretention at the Barnwell Street Lot.
  - Install a bioretention area or sand filter at the SC Probation Services building, install a green roof, and plant trees where feasible.
  - Add a retention pond within the property between Gregg and Laurens Street.
  - Install green roof units and bioretention areas or sand filters to all Richland County Government Buildings
  - Install tree boxes with underground detention cells along Taylor Street.
- South of Gervais, at the railroad west of Harden Street, stabilize the embankment behind the headwall at the railroad and stabilize outfalls at the south end of Laurens Street
- Stabilize the channel at the outfalls behind the Eden's property west of Saluda Avenue and downstream of Five Points.
- Addition of imperviousness is not recommended for this watershed without storage for excess runoff.

**Legend**

-  Infrastructure Improvements
-  Low Impact Development
-  Reforestation/Buffer Establishment
-  Stormwater Management
-  Stream Restoration
-  Open Stream Channel
-  Subwatershed



**Rocky Branch  
Watershed Assessment**

Figure 6.6:  
Gregg St Subwatershed  
Restoration Opportunities

0 500 1,000 Feet

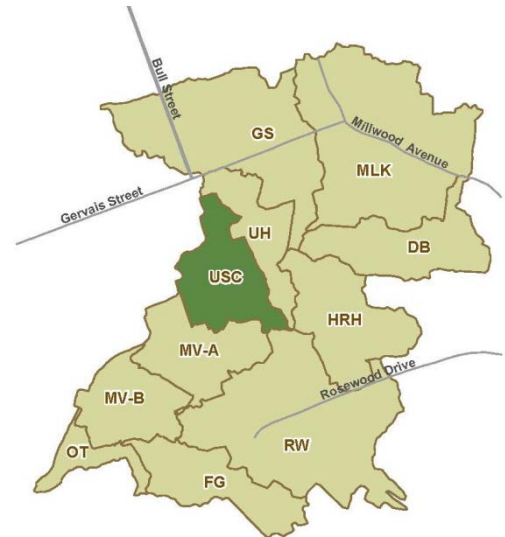


## 6.2 University of South Carolina Campus (USC) Subwatershed

### Introduction

#### Setting:

- The University of South Carolina Campus (USC) subwatershed is centrally located within the Rocky Branch watershed. USC is north of the MV-A subwatershed and northwest of the RW subwatershed.
- The subwatershed contains a large portion of the USC campus and portions of the Wales Garden neighborhood.
- 173 acres or 0.27 square miles in drainage area
- Contains 0.80 miles of open stream channel, and 8.17 miles of mapped storm drain/pipe
- Dominant land use designations (**Figure 6.1, Table 6.1**):
  - Developed, Medium Intensity: 55%
  - Developed, Low Intensity: 29%
- Impervious surface cover: 53%



**Figure 6.7 University of South Carolina Subwatershed**

**Soils:** Approximate soil type percentages within USC subwatershed include (refer to **Section 3.4** for soil descriptions and **Figure 6.8** for soil distributions):

- Urban land (Ur): 89%
- Orangeburg-Urban land complex, 2 to 6% slopes (OgB): 6%
- Fuquay-Urban land complex, 0 to 6% slopes (FyB): 5%




#### Overview:

The USC subwatershed incorporates a large portion of the USC campus and spans from Senate Street south to Whaley Street. Land use in USC is highly developed with large academic buildings, parking garages, and community buildings. Areas of developed green space such as Gibbes Green, provide refuge from the urbanized surroundings. Although the area is heavily developed, the campus has been landscaped to include trees, shrubs and other plantings.

### Existing Conditions

**Figure 6.9** highlights existing conditions that were either captured during the stream cruising effort or developed using GIS data.

**Legend**

-  Open Stream Channel
-  Soils
-  Subwatershed



**Rocky Branch  
Watershed Assessment**

Figure 6.8:  
USC Campus Subwatershed  
Soils

0 500 1,000 Feet



**Legend**

- Trash Dumping
- Pipe Outfall
- Near Stream Construction
- Possible Fish Barrier
- Exposed Pipe
- Bedrock
- Unmanaged Runoff
- Unusual Condition
- ~ Open Stream Channel
- Erosion Site
- Channel Alteration
- Inadequate Forest Buffer
- ☪ SWM Facility
- ☪ SWMM Subcatchment
- ☪ Subwatershed





Existing Condition	Count
Exposed Pipes	5
Pipe Outfalls	38
Unmanaged Runoff	4
Unusual Condition	2
Trash Dumping	0
Possible Fish Barrier	2
	<b>Linear Feet</b>
Erosion Site	98
Channel Alteration	983
Inadequate Forest Buffer	6,039

**Rocky Branch  
Watershed Assessment**

Figure 6.9:  
USC Campus Subwatershed  
Existing Conditions

N  
▲

0 500 1,000  
Feet

### Channel Conditions:



The upstream limit of open stream channel in the USC subwatershed is the Rocky Branch Mainstem within Maxcy Gregg Park. Stream banks are steep yet stable, with a thick layer of small trees and shrubs. Past riprap stabilization can be seen scattered along banks and in the stream bed. The channel substrate is primarily boulder and cobble material. The channel passes through a triple box culvert under Pickens Street and then continues downstream with similar channel conditions. This segment ends at the twin box culvert under Wheat Street.

South (downstream) of Wheat Street, the entire stream channel has been straightened and converted to a flat bottom concrete bed and vertical concrete banks. The concrete channel ends 500 feet downstream of Wheat Street. The channel bed is downcut into a large scour pool at the downstream limit of the concrete channel and the left bank is also highly unstable in this location. The channel is highly confined through this reach with the Solomon Blatt Physical Education Center and athletic fields along the right bank and the railroad embankment along the steep left bank. A balcony from the Physical Education Center overhangs the stream channel with pier supports within the active bed. The channel substrate is mostly coarse, with some fine deposition in the pools and some coarse mid-channel bars. The stream takes an abrupt turn at Sumter Street, through a road culvert identified as being in severe condition. This area acts as a pinch point and is modeled to produce a backwater condition at a 2-year storm event. The mainstem channel downstream of Sumter Street has concrete bed and banks that extend to the subwatershed boundary.



### *Ecology*

Stream habitat quality is fair within the upstream segment of open channel in Maxcy Gregg Park, then degrades downstream of Wheat Street. Within Maxcy Gregg Park, the channel is impacted by sedimentation, poor epifaunal substrate/available cover, and a lack of riparian buffer. The concrete channel downstream of Wheat Street offers uniformly poor habitat, though rigid bank stability. The reach downstream of the concrete channels exhibits similar issues as the segment within Maxcy Gregg Park.

Approximately 80% of the open stream channel within the USC subwatershed has a riparian buffer width narrower than 35 feet. Within Maxcy Gregg Park, the majority of the riparian buffer is narrow and invasive species have established along the banks and floodplain. In the section of natural channel downstream of Wheat Street, there are small trees and shrubs stabilizing the bank face, but channel encroachments do not support a riparian buffer on either side of the stream. The sections of concrete channel have no riparian vegetation.



---

## Constraints:

- Property Ownership:
  - Overall USC open channel:
    - Public: 28%
    - Private: 72%
  - Within 50 foot wide open channel buffer:
    - Public: 15%
    - Private: 85%
- Mapped Drainage Network:
  - Drain Pipe: 91%
  - Open Stream Channel: 9%
- Four longitudinal channel interruptions
- Channel encroachments: USC property, parking lots, railroad, and infrastructure

## SWM Assessment:

### *Facilities*

GIS data has identified three existing SWM facilities located within the USC subwatershed. The northernmost facility is located northwest of the intersection of Blossom Street and Pickens Street. The second SWM facility in the USC subwatershed is associated with Sustainable Carolina partnered with the USC Green Quad Learning Community. The final SWM facility in this subwatershed is located parallel to Sumter Street east of the bridge crossing for the Rocky Branch mainstem.

### *Outfalls*

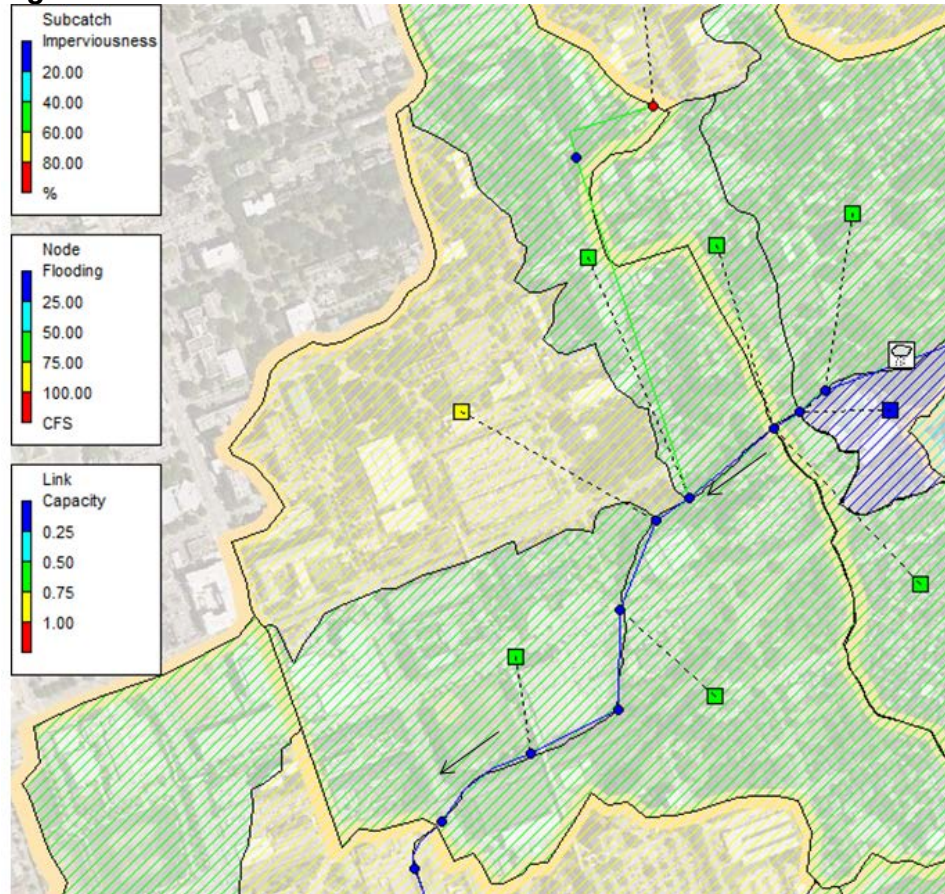
A field assessment of the USC subwatershed identified 38 outfalls, two of which were determined to be in severe condition. One of these outfalls is located off the southwest corner of the Solomon Blatt Physical Education Center. The headwall is partially undermined and a concrete stormwater flume leading to the back side of the headwall has shifted and segments are disconnected. The second outfall in severe condition is in the right bank approximately 150 feet upstream of Wheat Street. There is an eight foot vertical drop from this outfall to the mainstem and the headwall is partially undermined. Blue/green staining was noted in the discharge.

### *SWMM*

The USC subwatershed contains a dense assortment of university buildings combined with relatively high landscape slopes. The 173-acre subwatershed has an above average amount of impervious surface at 53%. Based on the SWMM modeling for a 2-year storm event, the subwatershed would produce approximately 5.9 peak cfs/acre, which is the highest amount among the entire watershed. The total runoff volume predicted for this type of storm is 11.2 million gallons, the fifth highest volume despite being only the seventh largest subwatershed. The runoff per area is predicted to be 8,690 cubic feet/acre, the third highest amount. As a result,

the USC subwatershed is ranked as the second highest for subwatershed runoff ranking, indicating that this subwatershed provides many opportunities for improvement.

**Figure 6.10 USC SWMM Model**



The USC subwatershed consists of four subcatchments in SWMM, all of them connecting directly to Rocky Branch. In this subwatershed, most of the hydraulic improvements recommended are along the Rocky Branch channel itself.

### **Total Subwatershed Runoff Ranking: 2**

### **Restoration Opportunities**

The following projects or similar improvements may be considered to address conditions identified in the USC subwatershed. These projects are included in **Figure 6.11**.








#### **Recommended Improvements:**

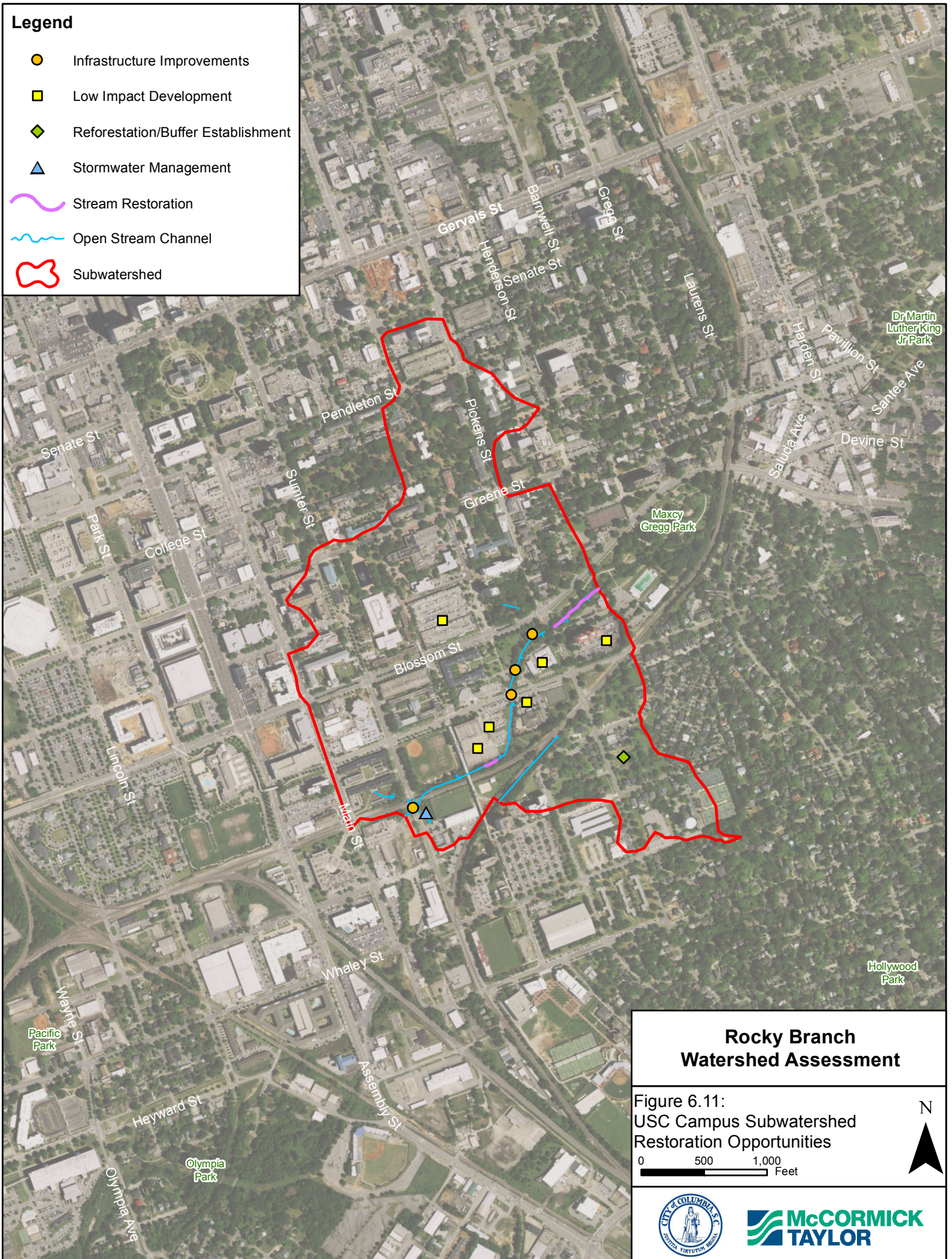
- Opportunities for infiltration and storage should be investigated here to reduce peaks downstream.
  - Retrofit the SWM pond at the USC Dance Facility Building, expand the footprint and convert to a shallow marsh



- For the Solomon Blatt Physical Education Center, install a green roof and add a bioretention area or sand filter to the parking lot
- Install bioretention boxes at the Children's Center at USC.
- Install a linear bioretention area to the parking garage at Blossom, Bull and Devine Streets
- Install a bioretention area to 1600 Park Circle
- At the ROTC building at USC, add a bioretention area to the parking lot.
- At Maxcy Gregg Park and northeast of Catawba and Pickens Streets, and Rice and Pickens Streets, add tree plantings where feasible.
- Bevel the top and sides at the entrance to the Wheat Street culvert over Rocky Branch to reduce entrance losses into the culvert. This structure is modeled to produce a backwater in existing conditions during a 2-year storm event.
- Modify the bridge at Pickens Street over Rocky Branch to remove the existing barriers and to create a beveled entrance in order to improve routing through the structure. Currently it is creating a backwater in existing conditions during a 2-year storm event.
- Restore the eroded outfall discharging into the stream behind the ROTC building
- Stabilize the stream bank behind the Solomon Blatt building
- Relocate the utility pipes away from the culvert at Sumter Street over Rocky Branch. This structure is modeled to produce a backwater condition at a 2-year storm event, and removing these pipes would provide greater capacity.
- Repair undercut sanitary line in stream bed within Maxcy Gregg Park, downstream of Pickens Street
- Addition of imperviousness is not recommended for this watershed without storage for excess runoff

**Legend**

-  Infrastructure Improvements
-  Low Impact Development
-  Reforestation/Buffer Establishment
-  Stormwater Management
-  Stream Restoration
-  Open Stream Channel
-  Subwatershed



## 6.3 Mill Villages A (MV-A) Subwatershed

### Introduction

#### Setting:

- The Mill Villages A (MV-A) subwatershed is located to the north of the MV-B subwatershed and to the west of the RW subwatershed.
- Within the subwatershed are portions of the USC campus, Olympia-Granby, and Wales Garden neighborhoods.
- 174 acres or 0.27 square miles in drainage area
- Contains 0.98 miles of open stream channel, and 5.0 miles of mapped storm drain/pipe
- Dominant land use designations (**Figure 6.1, Table 6.1**):
  - Developed, Medium Intensity: 58%
  - Developed, High Intensity: 25%
  - Developed, Low Intensity: 16%
- Impervious surface cover: 54%



**Figure 6.12 Mill Villages A Subwatershed**

**Soils:** Approximate soil type percentages within MV-A subwatershed include (refer to **Section 3.4** for soil descriptions and **Figure 6.13** for soil distributions):

- Urban land (Ur): 86%
- Orangeburg-Urban land complex, 6 to 15% slopes (OgD): 8%
- Orangeburg-Urban land complex, 2 to 6% slopes (OgB): 5%
- Lakeland-Urban land complex (LkB): 1%




#### Overview:

MV-A is the most urbanized subwatershed within the Rocky Branch watershed. The majority of area within the MV-A subwatershed is occupied by large buildings, athletic fields, and parking lots, ground cover is impermeable with little to no natural vegetation. This subwatershed encompasses the southern end of the USC campus. Assembly Street runs roughly mid-way through the subwatershed and is characterized by a straight thoroughfare, lack of curb and gutter in most locations, and an undivided roadway.

### Existing Conditions

**Figure 6.14** highlights existing conditions that were either captured during the stream cruising effort or developed using GIS data.

**Legend**

-  Open Stream Channel
-  Soils
-  Subwatershed



**Rocky Branch  
Watershed Assessment**

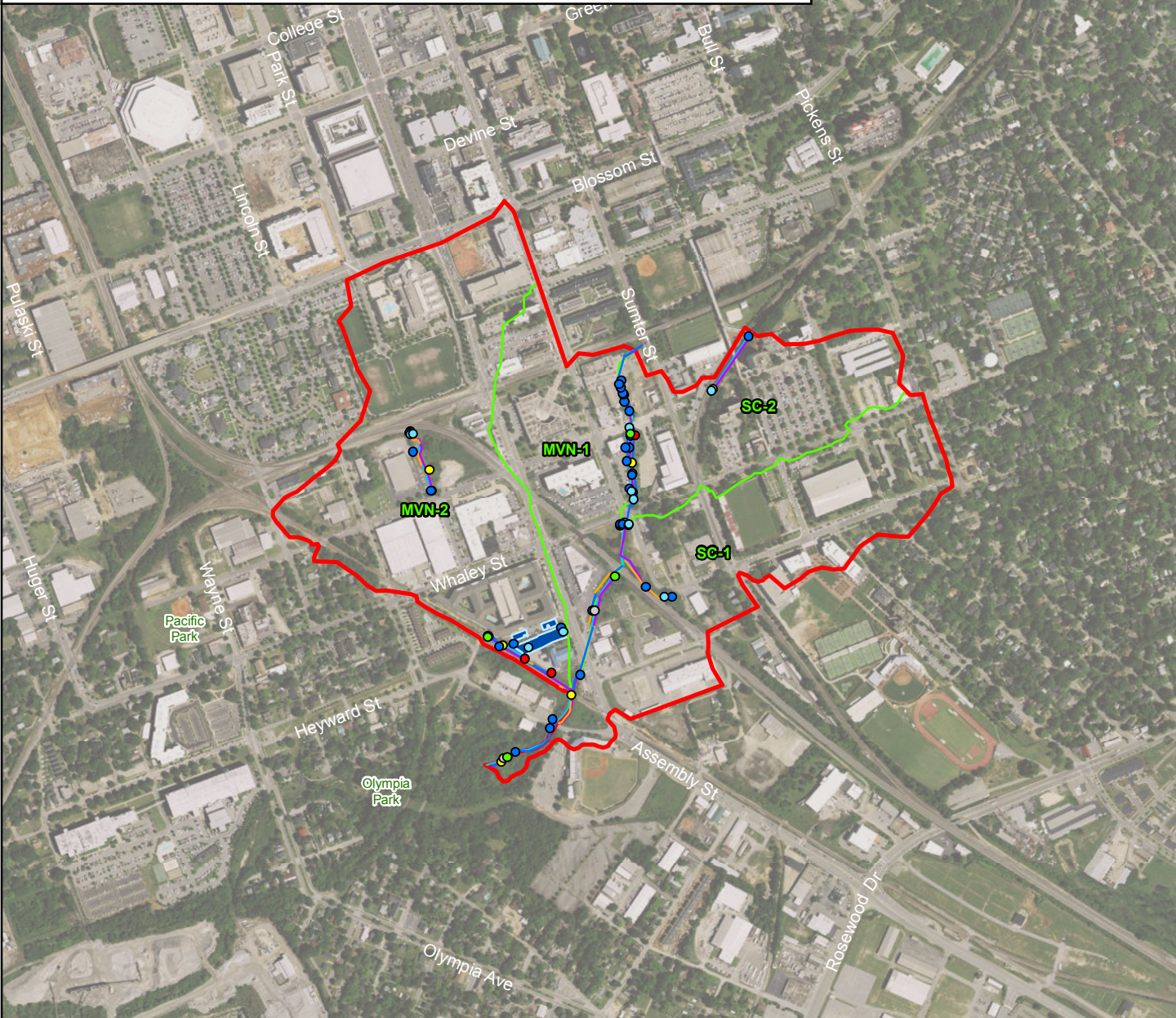
Figure 6.13:  
Mill Villages A Subwatershed  
Soils

0 500 1,000 Feet



**Legend**

- Trash Dumping
- Pipe Outfall
- Near Stream Construction
- Possible Fish Barrier
- Exposed Pipe
- Bedrock
- Unmanaged Runoff
- Unusual Condition
- ~ Open Stream Channel
- Erosion Site
- Channel Alteration
- Inadequate Forest Buffer
- ☪ SWM Facility
- ☪ SWMM Subcatchment
- ☪ Subwatershed





Existing Condition	Count
Exposed Pipes	5
Pipe Outfalls	13
Unmanaged Runoff	1
Unusual Condition	8
Trash Dumping	1
Possible Fish Barrier	0
	<b>Linear Feet</b>
Erosion Site	204
Channel Alteration	625
Inadequate Forest Buffer	2,580

**Rocky Branch  
Watershed Assessment**

Figure 6.14:  
Mill Villages A Subwatershed  
Existing Conditions

N  
▲

0 500 1,000  
Feet

### Channel Conditions:



The mainstem channel in the MV-A subwatershed begins just downstream of the Sumter Street crossing. The bed and banks are contained within a concrete trapezoidal channel with approximately 7-foot tall banks. The stream is open for a short segment before being covered by a 160-foot long bridge adjacent to the USC College of Engineering and Information Technology building. The stream emerges as open channel for 270 feet before passing under Catawba Street. The culvert at Catawba Street and the concrete crossing adjacent to the Engineering building were

both considered to be in severe condition due to the extent and condition of channel alteration and evidence of recent flooding. Downstream of Catawba Street, the concrete channel continues for 190 feet. Buckling and cracks were observed along the concrete bed downstream of Catawba. Downstream from the end of the concrete bed, the banks are stabilized with concrete for a short length along the right bank and timber retaining walls over the remainder of the bank surface. The channel then passes through a double box culvert under Whaley Street.

The downstream end of the culvert under Whaley Street opens up into a scour pool with large deposits of sand and gravel. A brick wall with multiple pipe outfalls stabilizes the left bank at the corner of Whaley and Main Street. The bed is mostly sand with cobble and gravel along the riffles. The stream passes through a large CMP culvert underneath a railroad crossing that show signs of bed incision and headwall cracking upstream. The skewed angle of entry and volume of flow at this junction likely contributes to reported flooding upstream. There is a steep concrete apron downstream of the culvert outfall and a deep scour pool immediately downstream of the apron. The concrete apron and scour pool may hinder fish passage due to the relatively large difference in elevation between the apron and the downstream channel and the shallow fast flow along the apron. The right bank downstream is approximately 12-foot tall and eroded, with pockets of gabion basket and riprap stabilization. The left bank is low and vegetated. The channel substrate is primarily sand, with some boulder, cobble, gravel and exposed bedrock along riffles. The downstream limit of this segment is at a double box culvert that conveys the stream under Assembly Street.



A tributary converges with the mainstem upstream of the railroad culvert. The channel is narrow and deeply incised, with approximately 10- to 12-foot tall banks. The channel is eroding parts of the railroad embankment along the left bank, causing slumping of embankment material.



Downstream of the road culvert at Assembly Street, the channel appears to have been historically straightened, with broken concrete, riprap, and gabion baskets stabilizing the 15-foot tall banks. The bed substrate consists primarily of sand, riprap and concrete. The stream passes under a railroad trestle and the substrate shifts to a higher concentration of boulder and cobble. Higher concentrations of trash were observed in this section, including a dumpster lodged underneath the railroad trestle. Bank heights are similar to the upstream region, although the left bank is eroding along most of the length between the railroad trestle and the culvert at Dreyfuss Road.

Upstream of the railroad trestle, a tributary converges with the mainstem on the right bank. The tributary is pinched between the railroad embankment to the south and a church parking lot and residential development to the north. The tributary initiates from a piped segment northeast of the Bluff Road and Cottonplace Lane intersection. Bank erosion is jeopardizing a gravel parking lot on the left bank and the channel is eroding parts of the railroad embankment along the right bank, causing severe slumping of embankment material. The right bank is 12 feet tall with an exposed, raw bank face. The channel substrate is mostly sand, with some gravel and cobble in the riffles.



The last mainstem segment passes through a forested parcel located west of the City baseball stadium and downstream of the culvert at Dreyfuss Road. Large broken concrete slabs are present throughout the channel, which may indicate past channelization or attempts to stabilize the banks. Despite the unnatural appearance of concrete rubble, stream banks are stable. The concrete slabs in the channel create small cascades that could potentially block fish passage. The channel substrate is primarily sand, with some large boulder, exposed bedrock, cobble and gravel.



A small open channel segment is located north of the Catawba Street and Park Street intersection, adjacent to the Richland Industrial building. The left floodplain is saturated and likely a wetland. The upstream end of this segment begins with two outfalls emerging from the railroad embankment. Approximately 20% of the banks are eroded, occurring on alternating banks along the outside of bends. The channel substrate is mostly gravel, with some sand and cobble.



Another short isolated stream segment exists adjacent to the railroad south of the USC Dance Company building. The channel is ephemeral, following the railroad, with low, stable banks and sand and gravel substrate.

### *Ecology*

Stream habitat quality within the streams of the MV-A subwatershed is generally poor. The channel segment adjacent to the USC College of Engineering and Information Technology building has greatly diminished habitat quality as a result of the concrete bed and banks providing no vegetative cover or riparian buffer, little epifaunal substrate/available cover, and excessive channel alteration. Downstream of the concrete channel, habitat improves marginally, though is degraded by sedimentation, lack of epifaunal substrate/ available cover and channel alteration. Sedimentation and marginal epifaunal substrate/available cover continues downstream of Whaley Street and bank stability and vegetative cover decreases as the channel conveys through the railroad culvert. West of Assembly Street, bank instability and poor vegetative cover continues to be an issue. Bank stability improves downstream of Dreyfuss Road, but sedimentation increases. Habitat quality within the isolated segment north of Catawba Street is in poor condition, impacted by marginal epifaunal substrate/available cover, high channel alteration, bank instability and marginal vegetative cover.

Approximately 80% of the banks are lacking riparian buffer width greater than 35 feet. The only stream reach that has adequate riparian vegetation is located in the downstream extent of the subwatershed, near the City Stadium. The floodplain in this area consists of mature trees and a well-established understory.

### **Constraints:**

- Property Ownership:
  - Overall MV-A open channel:
    - Public: 26%
    - Private: 74%
  - Within 50 foot wide open channel buffer:
    - Public: 16%
    - Private: 84%
- Mapped Drainage Network:
  - Drain Pipe: 84%
  - Open Stream Channel: 16%
- Eight longitudinal channel interruptions
- Channel encroachments: parking lots, railroad, commercial buildings

### **SWM Assessment:**

#### *Facilities*

Within the MV-A subwatershed, there are three mapped BMP locations included in City GIS data. Upon field inspection, it appears the three individual SWM facilities are all connected, two of which appear to be incorporated into the parking lot of the Aspyre at Assembly Station

apartment building, at Assembly and Heyward Streets. The largest facility of the three is adjacent to the two parking lot BMP's upslope.

### *Outfalls*

Thirty-eight outfalls were identified within the MV-A subwatershed during the field assessment. Two of these outfalls rated severe and one was rated very severe. The outfall rated very severe and one outfall rated severe are located south of the railroad at the head of the channel north of the Catawba Street and Park Street intersection. The railroad embankment has scoured and slumped behind the headwall, the headwall is undermined and cracked. Erodible soils and heavy erosion above and around the pipe are endangering the railroad embankment from which the outfall emerges. The other outfall in severe condition is located in the channel segment south of Catawba street. The pipe is fully inundated at baseflow, with 75% of the opening blocked with deposition

### *SWMM*

The MV-A subwatershed lies to the south of the USC area and has the second highest value of impervious surface at 54%. The MV-A subwatershed is only 175 acres, but the SWMM model predicts for a 2-year storm event that the area will produce 11.4 million gallons of runoff, which is the fourth highest in the watershed. The discharge per acre for a 2-year storm event is modeled at 5.7 peak cfs/acre, putting it at the third highest amount within Rocky Branch, and 8,675 cubic feet/acre, which is fourth highest among the subwatersheds. As a result, the MV-A subwatershed received a higher subwatershed runoff ranking.

**Figure 6.15 MV-A SWMM Model**





This subwatershed is modeled as four subcatchments in SWMM. The flows from these subcatchments are linked directly to Rocky Branch. The model does not indicate any flooding occurring in the subcatchments as a result of overburdened drainage pipes.

### **Total Subwatershed Runoff Ranking: 3**








#### **Restoration Opportunities**

The following projects or similar improvements may be considered to address conditions identified in the MV-A subwatershed. These projects are included in **Figure 6.16**.

#### **Recommended Improvements:**

- Opportunities for infiltration and storage should be investigated here to reduce peaks downstream.
  - Opportunity for a BMP or additional storage in the open space between Whaley Street and the downstream railroad bridge.
  - Retrofit the pond at Assembly and Heyward, expanding the footprint and converting to a shallow marsh or infiltration basin.
- Remove biological barriers and potentially enlarge the culvert at the railroad bridge between Whaley and Assembly Streets. This structure is modeled to create a backwater in existing conditions during a 2-year storm event.
- Increase the size of the culverts at Catawba and Whaley Streets to dual 20-foot by 6-foot and dual 25-foot by 6-foot.
- Daylight the channel of the mainstem of Rocky Branch from Sumter to Whaley.
- Remove the poured concrete structures partially blocking the culvert entrance and exit near the USC Building above Catawba Street.
- At the Catawba Street crossing of Rocky Branch, remove the old concrete structures on either side of the channel at the top. In addition, bevel the top of the culvert and trim vegetation downstream. This structure is modeled to produce a backwater in existing conditions for a 2-year storm event.
- Stabilize the streambanks of the segments between Assembly Street and the railroad, behind the Church of Jesus Christ, and between Dreyfuss Road the railroad.
- Restore the tributary between Catawba Street and the railroad by Richland Industrial.
- Addition of imperviousness is not recommended for this watershed without storage for excess runoff.

**Legend**

-  Infrastructure Improvements
-  Low Impact Development
-  Reforestation/Buffer Establishment
-  Stormwater Management
-  Stream Restoration
-  Open Stream Channel
-  Subwatershed



**Rocky Branch  
Watershed Assessment**

Figure 6.16:  
Mill Villages A Subwatershed  
Restoration Opportunities

0 500 1,000  
Feet

N

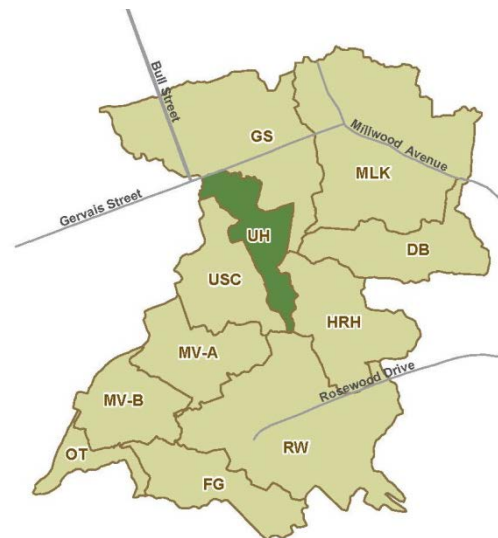


## 6.4 University Hill (UH) subwatershed

### Introduction

#### Setting:

- The University Hill (UH) subwatershed is centrally located within the Rocky Branch watershed. The USC subwatershed is to the southwest of the UH subwatershed and the RW subwatershed is to the south.
- This subwatershed is the second smallest within the watershed and is situated to the northeast of the USC campus, with Gervais Street at the northwest boundary and Enoree Avenue to the southeast.
- 125 acres or 0.20 square miles in drainage area
- Contains 0.25 miles of open stream channel, and 4.44 miles of mapped storm drain/pipe
- Land use designations (**Figure 6.1, Table 6.1**):
  - Developed, Medium Intensity: 55%
  - Developed, Low Intensity: 28%
- Impervious surface cover: 54%



**Figure 6.17 University Hill Subwatershed**

**Soils:** Approximate soil type percentages within UH subwatershed include (refer to **Section 3.4** for soil descriptions and **Figure 6.18** for soil distributions):

- Urban land (Ur): 82%
- Fuquay-Urban land complex, 0 to 6% slopes (FyB): 13%
- Orangeburg-Urban land complex, 2 to 6% slopes (OgB): 5%
- Orangeburg-Urban land complex, 6 to 15% slopes (OgD): <1%




#### Overview:

The UH subwatershed includes portions of the USC campus. The western region contains academic buildings, hard landscaping, and recreational facilities. To the east and south, single-family detached and attached homes and apartment buildings are prevalent. The UH subwatershed is home to the Maxcy Gregg Park and Pool. This park is landscaped with trees, shrubs, mowed grass, and other plantings, contains lighting, and a meandering mixed use path that travels along the stream. A large area of this park is occupied by the public pool and associated facilities.

### Existing Conditions

**Figure 6.19** highlights existing conditions that were either captured during the stream cruising effort or developed using GIS data.

**Legend**

-  Open Stream Channel
-  Soils
-  Subwatershed



**Rocky Branch  
Watershed Assessment**

Figure 6.18:  
University Hill Subwatershed  
Soils

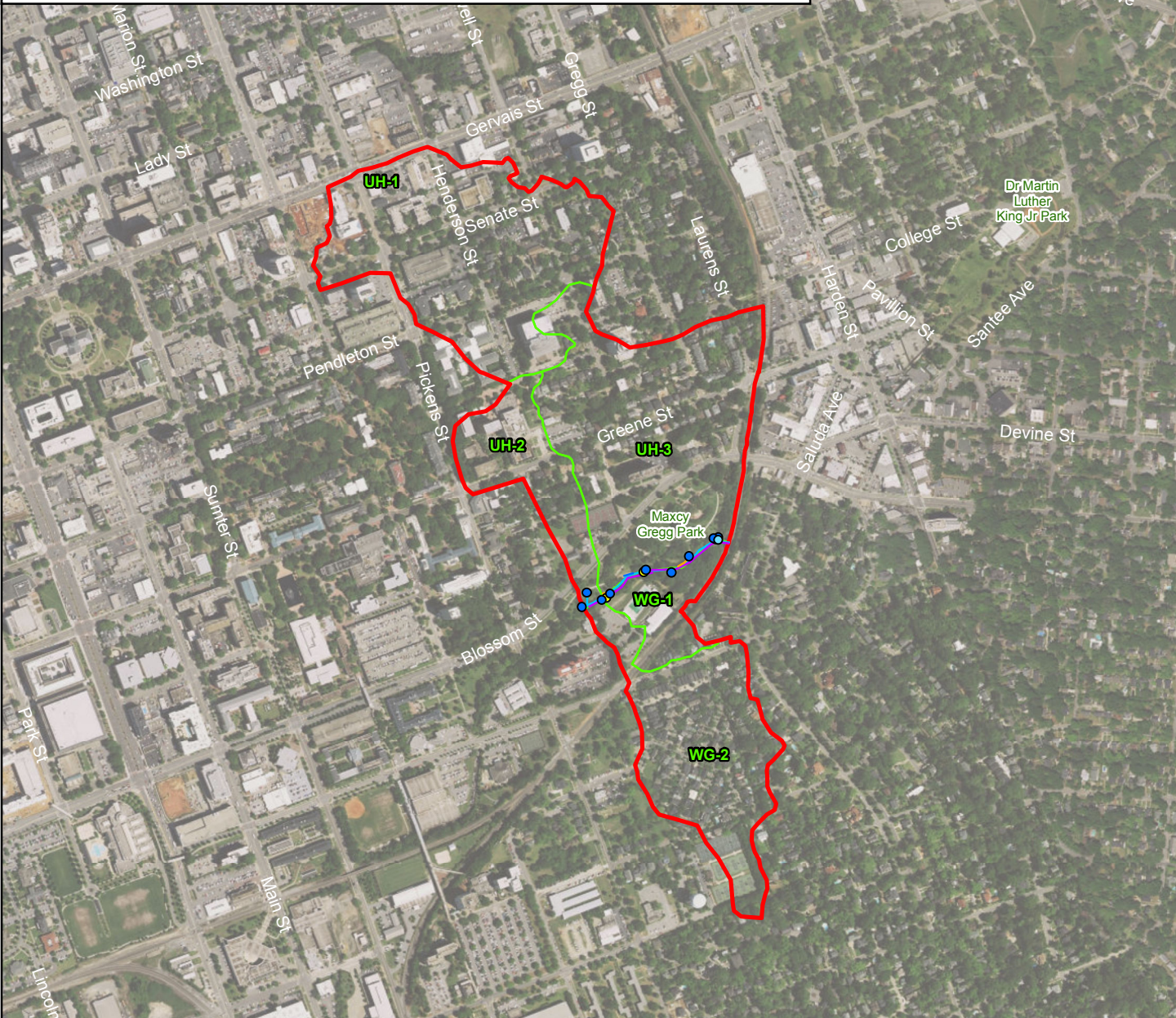
0 500 1,000  
Feet

N



**Legend**

- Trash Dumping
- Pipe Outfall
- Near Stream Construction
- Possible Fish Barrier
- Exposed Pipe
- Bedrock
- Unmanaged Runoff
- Unusual Condition
- ~ Open Stream Channel
- Erosion Site
- Channel Alteration
- Inadequate Forest Buffer
- SWM Facility
- SWMM Subcatchment
- Subwatershed



Existing Condition	Count
Exposed Pipes	1
Pipe Outfalls	9
Unmanaged Runoff	0
Unusual Condition	3
Trash Dumping	0
Possible Fish Barrier	0
	<b>Linear Feet</b>
Erosion Site	173
Channel Alteration	59
Inadequate Forest Buffer	1,501

**Rocky Branch  
Watershed Assessment**

Figure 6.19:  
University Hill Subwatershed  
Existing Conditions

0 500 1,000  
Feet

N

## Channel Conditions:



The UH subwatershed contains a small section of open channel along the mainstem of Rocky Branch and located entirely within Maxcy Gregg Park. The upstream limit is an old, degrading railroad trestle that crosses the stream at the subwatershed boundary. A sanitary line is exposed along the bed spanning 50 feet directly beneath the railroad trestle. Immediately downstream of the trestle, a stacked stone wall is along the right stream bank and riprap stabilizes the left. Several isolated sections of bank erosion occur along the right bank throughout Maxcy

Gregg Park. Stream banks have been armored with riprap throughout the park. The channel substrate is primarily boulder and cobble, with some sandy depositional bars intermittently located throughout the reach.

## Ecology

Stream habitat is in fair condition within the UH subwatershed. Sedimentation issues, a poor velocity/depth regime and a lack of epifaunal substrate/ available cover were the greatest impairments to the general habitat quality. At the upstream end near the railroad trestle, a very strong chemical odor and cloudy, green water color was observed. Approximately 70% of the stream banks had less than a 35-foot riparian buffer width. The upstream portion of the left bank had the most established vegetative growth. The remainder of the buffer had sporadic mature tree growth among mowed grass and low herbaceous vegetation.

## Constraints:

- Property Ownership:
  - Overall UH open channel:
    - Public: 42%
    - Private: 58%
  - Within 50 foot wide open channel buffer:
    - Public: 94%
    - Private: 6%
- Mapped Drainage Network:
  - Drain Pipe: 95%
  - Open Stream Channel: 5%
- One longitudinal channel interruption
- Channel encroachments: park infrastructure including a pedestrian bridge, railroad at the upstream limit



**SWM Assessment:**

*Facilities*

There are no SWM facilities located within the UH subwatershed.

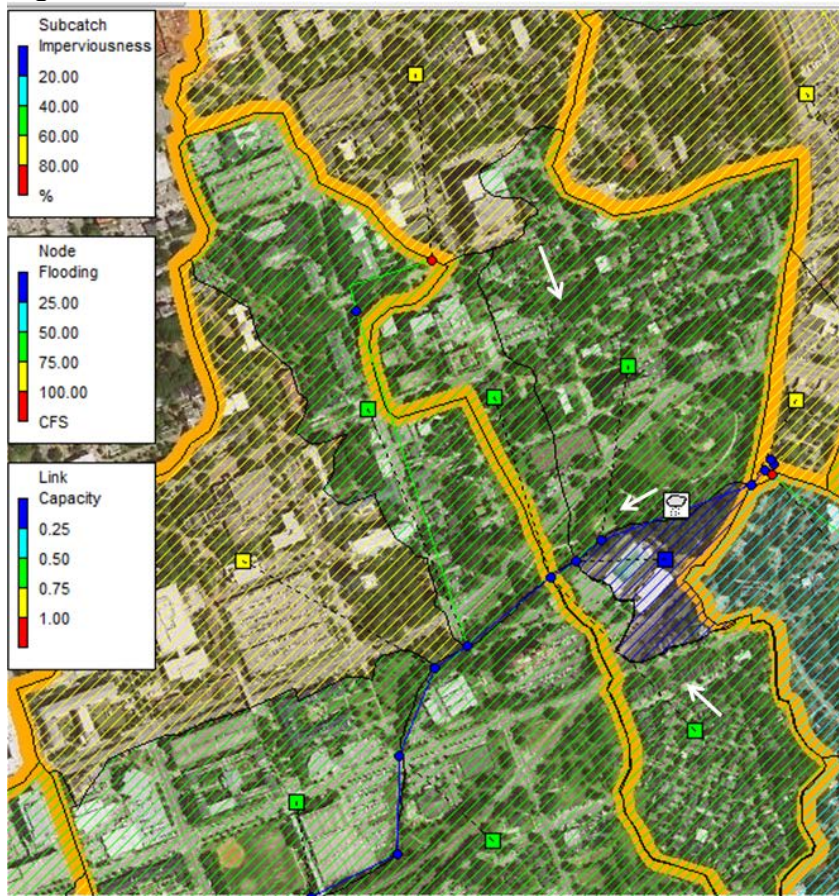
*Outfalls*

All outfalls within the UH subwatershed were observed to be in minor to moderate condition.

*SWMM*

The UH subwatershed is one of the smaller subwatersheds at 125 acres, but it has a higher than average amount of impervious surface at 54%. As a result, the SWMM model predicts that a 2-year storm event will produce 5.9 peak cfs/acre, the second highest value for the watershed. The total runoff volume is below the watershed average (12.8) at 8.6 million gallons for a 2-year storm event. However, the runoff per area is the second highest in the watershed at 9,224 cubic feet/acre. The higher impervious surface and runoff per area values lead to this subwatershed being ranked in the upper subwatershed runoff rankings as shown below.

**Figure 6.20 UH SWMM Model**





The UH subwatershed consists of five subcatchments in SWMM, with four of them having flows connecting directly to Rocky Branch. At the 2-year event, the pipes modeled are at approximately 70% capacity and flooding is indicated at the upper end of the watershed.

**Total Subwatershed Runoff Ranking: 4**








**Restoration Opportunities**

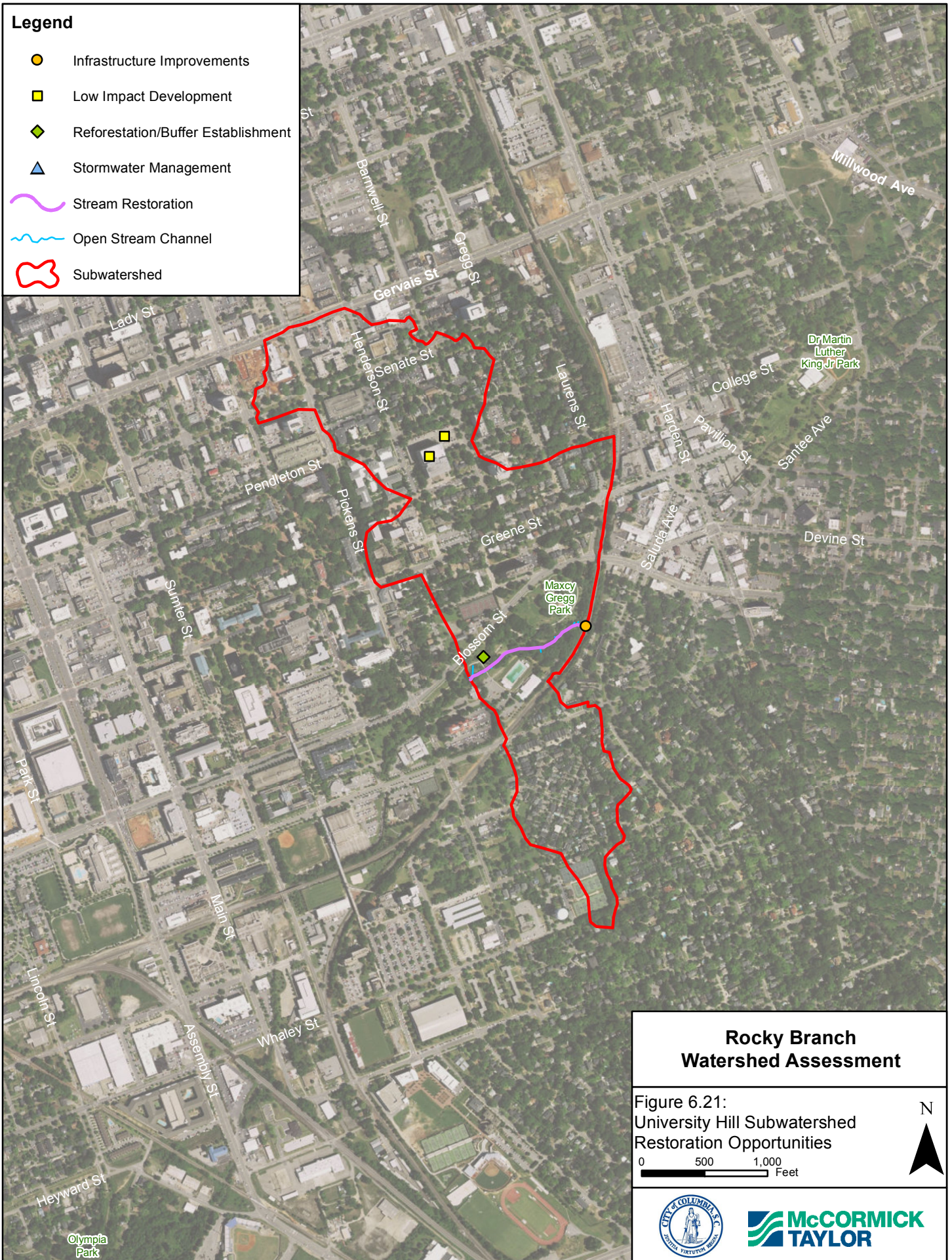
The following projects or similar improvements may be considered to address conditions identified in the UH subwatershed. These projects are included in **Figure 6.21**.

**Recommended Improvements:**

- Opportunities for infiltration and storage should be investigated here to reduce peaks downstream.
  - Install green roof units and add a bioretention area and sand filter to the Close-Hipp Building.
- Replace the railroad bridge above Maxcy Gregg Park with a full span structure. It is near the end of its service life and there is substantial scour upstream of the bridge.
- Restore the mainstem Rocky Branch within Maxcy Gregg Park, removing invasive species, stabilizing banks, reconnecting the floodplain, and establishing a riparian buffer.
- Addition of imperviousness is not recommended for this watershed without storage for excess runoff.

**Legend**

-  Infrastructure Improvements
-  Low Impact Development
-  Reforestation/Buffer Establishment
-  Stormwater Management
-  Stream Restoration
-  Open Stream Channel
-  Subwatershed

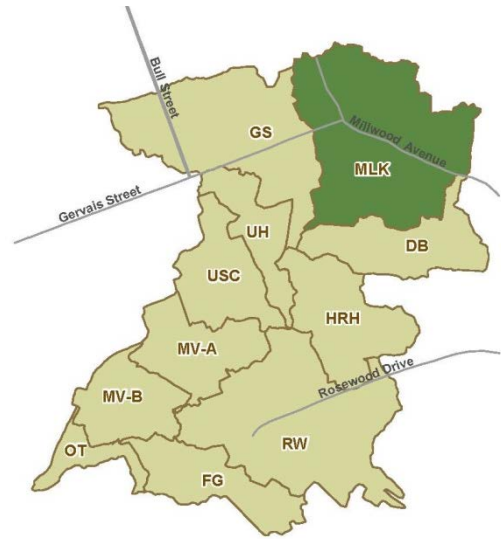


## 6.5 Martin Luther King Jr. (MLK) Subwatershed

### Introduction

#### Setting:

- The Martin Luther King JR. (MLK) subwatershed is the northeastern most, and largest, subwatershed within the Rocky Branch watershed.
- MLK’s downstream end falls between the GS and DB subwatersheds, extends north approximately 1 mile to slightly north of Forest Drive. The Gervais Street, Millwood Avenue intersection is at the northwest.
- 503 acres or 0.79 square miles in drainage area
- Contains 0.35 miles of open stream channel, and 11.61 miles of mapped storm drain/pipe
- Dominant land use designations (**Figure 6.1, Table 6.1**):
  - Developed, Low Intensity: 46%
  - Developed, Medium Intensity: 34%
  - Developed, Open Space: 12%
- Impervious surface cover: 47%



**Figure 6.22 Martin Luther King Jr. Subwatershed**

**Soils:** Approximate soil type percentages within MLK subwatershed include (refer to **Section 3.4** for soil descriptions and **Figure 6.23** for soil distributions):

- Urban land (Ur): 56%
- Orangeburg-Urban land complex, 2 to 6% slopes (OgB): 16%
- Dothan-Urban land complex, 0 to 6% slopes (DuB): 16%
- Orangeburg-Urban land complex, 6 to 15% slopes (OgD): 11%
- Vauclose loamy sand, 10 to 15% slopes (VaD): <1%




#### Overview:

The MLK subwatershed is not only the largest basin within the Rocky Branch watershed, with diverse in land use. Commercial districts, parks and recreational facilities, open space, and residential communities are all represented. Along with the DB and GS subwatersheds, MLK encompasses a portion of the Five Points neighborhood. This is the most densely developed area in MLK with large commercial buildings along with associated parking lots. Millwood Avenue is also a commercial oriented corridor within MLK. Parks include MLK Park at the southern end of the subwatershed, and Anna Mae Dickson Mini Park and St. Anna’s Park to the north.

### Existing Conditions

**Figure 6.24** highlights existing conditions that were either captured during stream cruising efforts or developed using GIS data.

**Legend**

-  Open Stream Channel
-  Soils
-  Subwatershed



**Rocky Branch  
Watershed Assessment**

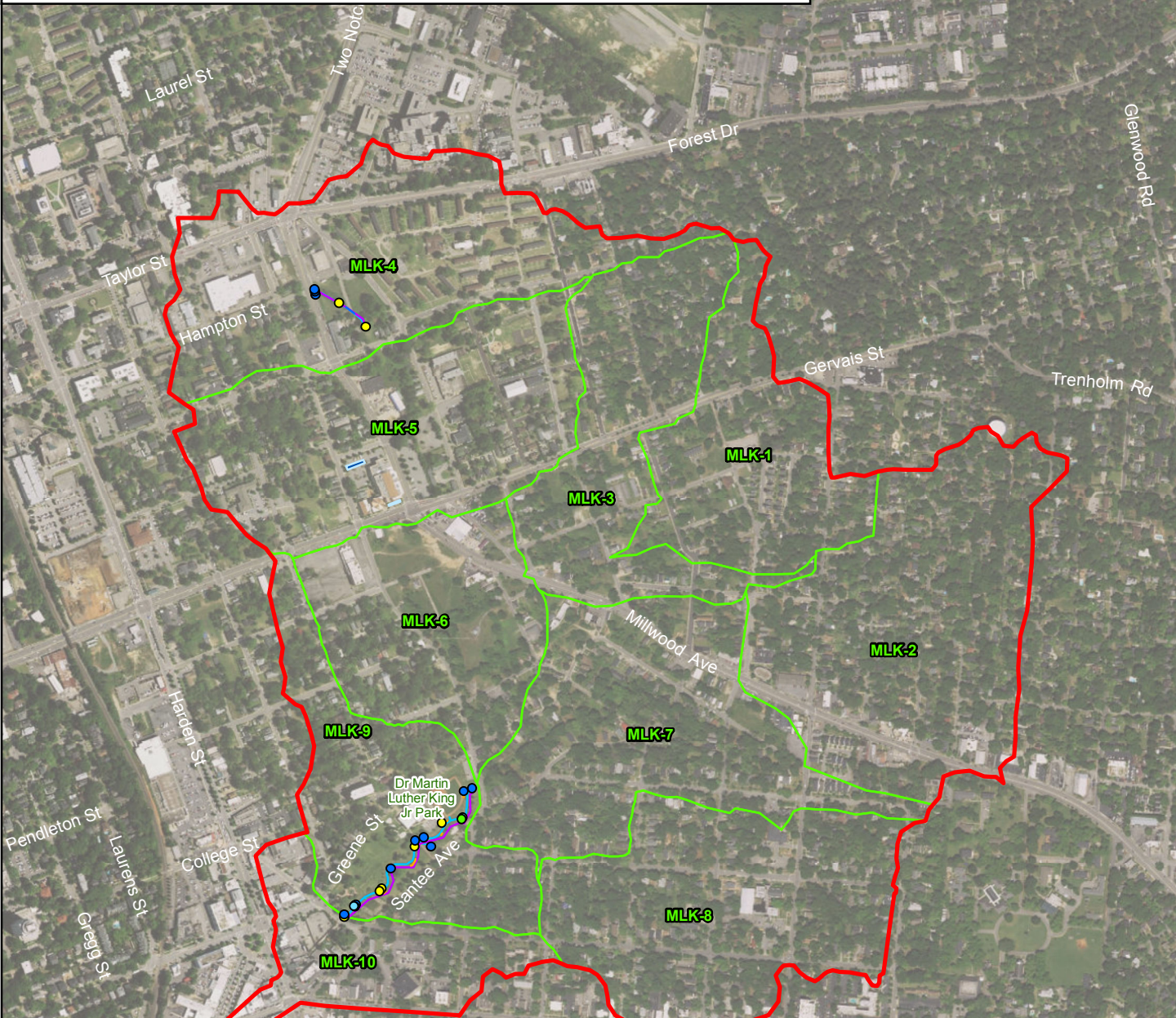
Figure 6.23:  
Martin Luther King Jr. Subwatershed  
Soils

0 500 1,000  
Feet



**Legend**

- Trash Dumping
- Pipe Outfall
- Near Stream Construction
- Possible Fish Barrier
- Exposed Pipe
- Bedrock
- Unmanaged Runoff
- Unusual Condition
- ~ Open Stream Channel
- Erosion Site
- Channel Alteration
- Inadequate Forest Buffer
- 🏊 SWM Facility
- 🏊 SWMM Subcatchment
- 🏊 Subwatershed





Existing Condition	Count
Exposed Pipes	2
Pipe Outfalls	13
Unmanaged Runoff	0
Unusual Condition	7
Trash Dumping	0
Possible Fish Barrier	1
Linear Feet	
Erosion Site	274
Channel Alteration	88
Inadequate Forest Buffer	3,491

**Rocky Branch  
Watershed Assessment**

Figure 6.24:  
Martin Luther King Jr. Subwatershed  
Existing Conditions

N  
▲

0 500 1,000  
Feet



### Channel Conditions:



There are only two segments of open channel in the entire subwatershed. The first, and smaller of the two segments, is located in the northern portion of the subwatershed, east of the Hampton Street and North Millwood Avenue intersection. The channel segment begins at a gabion headwall at North Millwood Avenue and contains three individual stormwater outfalls. The banks are stabilized with thick vegetation primarily consisting of small trees and shrubs. The stream bed substrate consists primarily of sand and silt. Previous flooding levels are indicated

by organic matter along the stream banks and refuse scattered throughout tree limbs approximately three to four feet above the channel bed. Ground cover and soils directly adjacent to the current stream channel appear to be saturated. The stream is conveyed through a road culvert at Ontario Street and is open for a short segment before entering the piped network north of Washington Street.

The second open channel segment in this subwatershed begins at the northeastern edge of MLK Park, where the stream emerges from underneath Heidt Street. The open channel section within MLK Park was recently restored using natural channel design and stabilization techniques. The entire stream corridor within the park is fenced in. Grade controls including large boulders across the bed and bank stabilization are present throughout this segment. Isolated areas of erosion are located along the outsides of bends, resulting in sediment sloughing off of the 6 to 7-foot banks and portions of the park fence falling down the eroding slopes. Adjacent to Heidt Street, an exposed 18-inch sanitary pipe was observed crossing the stream. A cross vane structure is located immediately downstream of this pipe crossing. Erosion was observed along the left bank caused by the channel flanking the structure. A beaver dam located downstream of the park pedestrian bridge has altered the restored channel by causing localized backwater conditions. Further downstream, another exposed sanitary pipe was observed, and is spanning above base flow. The stream then enters a culvert beneath Pavilion Avenue and is piped through the Five Points neighborhood, eventually emerging in the southern portion of the Gregg Street subwatershed.



### *Ecology*

Stream habitat quality is generally poor along both of the open channel segments in the MLK subwatershed. Common impairments observed included lack of riparian buffer, sedimentation issues and poor epifaunal substrate/available cover. The segment in the northern part of the subwatershed also had poor channel flow status (baseflow condition) and inadequate velocity/depth regime representation. Petroleum (fuel-like) odors were observed within this



segment. The reach within MLK Park had higher proportions of unstable/eroding banks compared to other reaches within the MLK subwatershed, but was generally in slightly better ecological condition.

The entire stream network within the MLK subwatershed has riparian buffer narrower than 35 feet. While some vegetation was observed along the stream banks of both segments, the riparian buffer region consists primarily of mowed grass.

**Constraints:**

- Property Ownership:
  - Overall MLK open channel:
    - Public: 31%
    - Private: 69%
  - Within 50 foot wide open channel buffer:
    - Public: 83%
    - Private: 17%
- Mapped Drainage Network:
  - Drain Pipe: 97%
  - Open Stream Channel: 3%
- Two longitudinal channel interruptions
- Channel encroachments: utility lines, parks and recreation facilities, parking lots, community buildings

**SWM Assessment:**

*Facilities*

Based on GIS data, the following BMPs were documented within the MLK subwatershed. At 1231 Heidt Street, two BMPs are included in City GIS. During field review, no facilities were visible. It is possible that the BMPs are underground

*Outfalls*

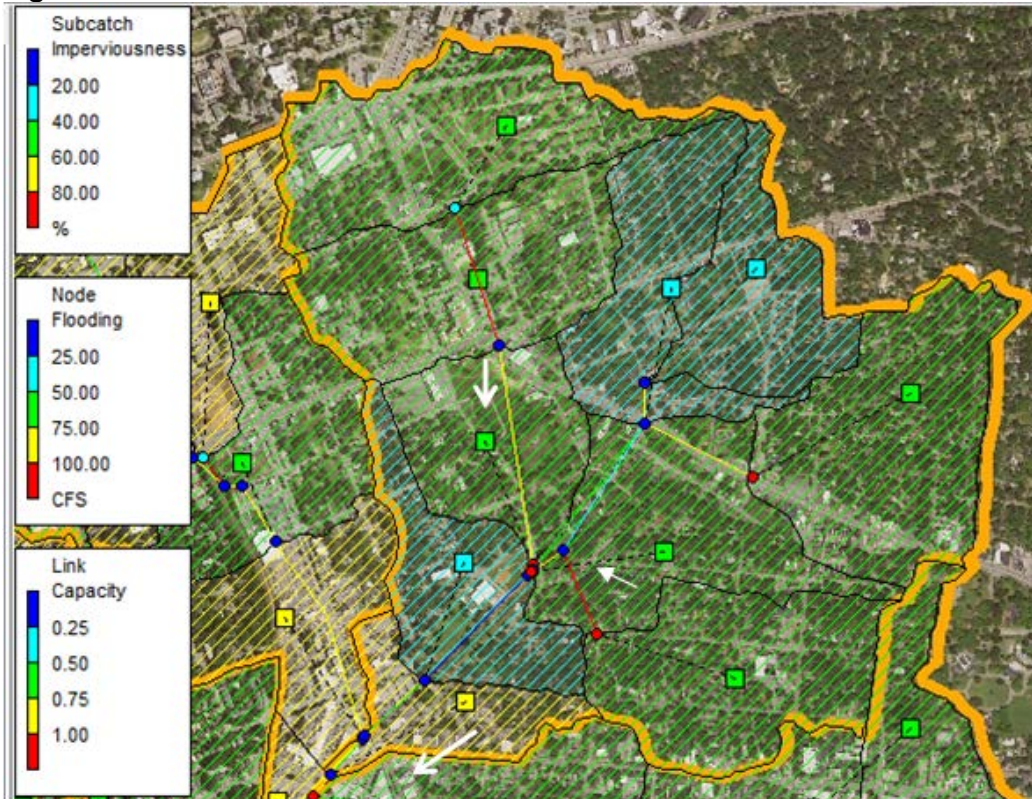
Fifteen outfalls were identified within the MLK subwatershed. All outfalls were characterized in fair to good condition.

*SWMM*

The MLK subwatershed is one of the three contributing subwatersheds to Five Points and is also primarily residential. The SWMM modeling for the MLK subwatershed predicts that a 2-year storm event would produce a peak of 5.1 peak cfs/acre, which is the fourth highest amount for the watershed. The MLK subwatershed has just above average impervious surface (47%) compared to the rest of the watershed, but higher slopes contribute to quicker and higher runoff peaks. In addition, the subwatershed is the largest in size at 503 acres, and as a result, the total runoff volume modeled for a 2-year storm event is 25.7 million gallons, the second highest

within the watershed. However, its runoff per area is modeled at 6,828 cubic feet/acre, which is only the fifth highest among the subwatersheds.

**Figure 6.25 MLK SWMM Model**



The MLK subwatershed was modeled as 10 subcatchments draining through various trunk lines to final outlets at MLK Park. Flooding is modeled to begin at the 2-year event, as the storm drains are at or near capacity.

**Total Subwatershed Runoff Ranking: 5**

### Restoration Opportunities

The following projects or similar improvements may be considered to address conditions identified in the MLK subwatershed. These projects are included in **Figure 6.26**.








### **Recommended Improvements**

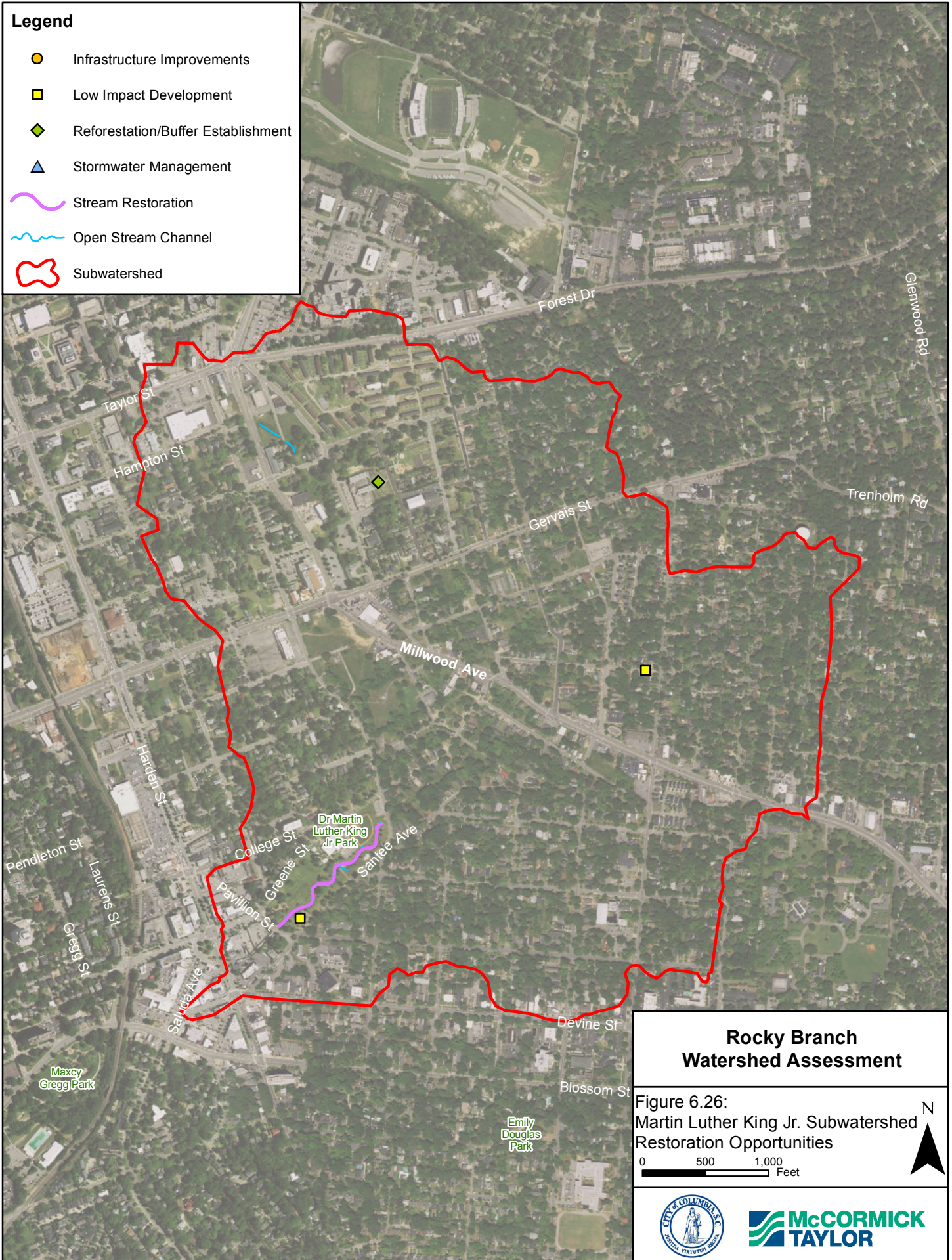
- Culverts extending underneath of Five Points should be inspected for any blockages as well as for structural integrity
- Opportunities for infiltration and storage should be investigated here to reduce peaks downstream
  - Add tree plantings to St. Anna's Park
  - Install a bioretention area or sand filter within MLK Park



- Apply green streets template to reduce runoff from Melrose Heights and Old Shandon neighborhoods
- Stabilize the banks within the stream segment in MLK Park
- Addition of imperviousness is not recommended for this watershed without storage for excess runoff.
- Perform further SWMM modeling in this area locate infrastructure in need of improvement

**Legend**

-  Infrastructure Improvements
-  Low Impact Development
-  Reforestation/Buffer Establishment
-  Stormwater Management
-  Stream Restoration
-  Open Stream Channel
-  Subwatershed



**Rocky Branch  
Watershed Assessment**

Figure 6.26:  
Martin Luther King Jr. Subwatershed  
Restoration Opportunities

0 500 1,000  
Feet



## 6.6 Devine Blossom (DB) Subwatershed

### Introduction

#### Setting:

- The Devine Blossom (DB) subwatershed is located directly north of the HRH subwatershed
- This subwatershed encompasses the northwest portion of the Shandon neighborhood from Wilmot Avenue to its northernmost point at Millwood Avenue (US-378). The east-west boundaries are from Sims Avenue to Saluda Avenue.
- 165 acres or 0.26 square miles in drainage area
- Contains no open stream channel, and 3.40 miles of mapped storm drain/pipe
- Dominant land use designations (**Figure 6.1, Table 6.1**):
  - Developed, Medium Intensity: 36%
  - Developed Low Intensity: 34%
  - Developed, Open Space: 18%
- Impervious surface cover: 47%



**Figure 6.27 Devine Blossom Subwatershed**

**Soils:** Approximate soil type percentages within DB subwatershed include (refer to **Section 3.4** for soil descriptions and **Figure 6.28** for soil distributions):

- Orangeburg-Urban land complex, 2 to 6% slopes (OgB): 37%
- Orangeburg-Urban land complex, 6 to 15% slopes (OgD): 21%
- Urban land (Ur): 42%




#### Overview:

The DB subwatershed is widely residential with single-family detached, single-family attached homes, and condominiums prevalent. However, the eastern/downstream limits of this subwatershed include a portion of Five Points, which is almost entirely impermeable groundcover. Other than street plantings, large commercial buildings and parking lots leave no open green space within Five Points. Devine Street is an east-west roadway traversing through the DB subwatershed. A commercial oriented corridor, this area is tree lined, lots are landscaped, and businesses are within detached buildings.

### Existing Conditions

**Figure 6.29** highlights existing conditions that were either captured during the stream cruising effort or developed using GIS data.

**Legend**

-  Open Stream Channel
-  Soils
-  Subwatershed



**Rocky Branch  
Watershed Assessment**

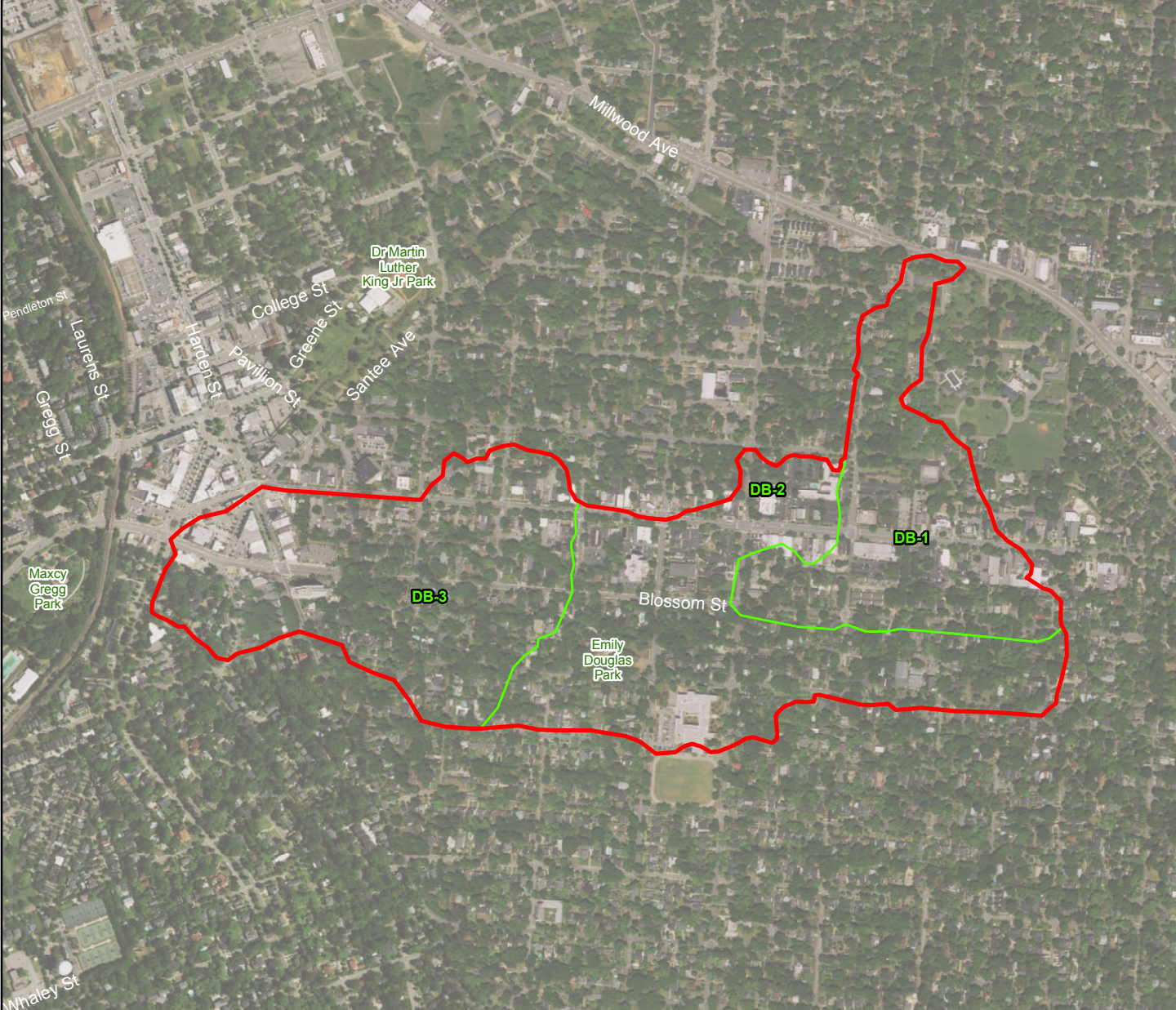
Figure 6.28:  
Devine Blossom Subwatershed  
Soils

0 500 1,000  
Feet



**Legend**

- Trash Dumping
- Pipe Outfall
- Near Stream Construction
- Possible Fish Barrier
- Exposed Pipe
- Bedrock
- Unmanaged Runoff
- Unusual Condition
- ~ Open Stream Channel
- Erosion Site
- Channel Alteration
- Inadequate Forest Buffer
- SWM Facility
- SWMM Subcatchment
- Subwatershed





Existing Condition	Count
Exposed Pipes	0
Pipe Outfalls	0
Unmanaged Runoff	0
Unusual Condition	0
Trash Dumping	0
Possible Fish Barrier	0
Linear Feet	
Erosion Site	0
Channel Alteration	0
Inadequate Forest Buffer	0

**Rocky Branch  
Watershed Assessment**

Figure 6.29:  
Devine Blossom Subwatershed  
Existing Conditions

0 500 1,000  
Feet

N  
▲



---

### **Channel Conditions:**

There are no open stream channel segments in the DB subwatershed.

### **Constraints:**

- Property ownership
  - Overall DB open channel:
    - Public: 32%
    - Private: 68%
  - Within 50 foot wide open channel buffer:
    - Public: N/A
    - Private: N/A
- Mapped Drainage Network:
  - Drain Pipe: 100%
  - Open Stream Channel: 0%

### **SWM Assessment:**

#### *Facilities*

There are no mapped SWM facilities located within the DB subwatershed.

#### *Outfalls*

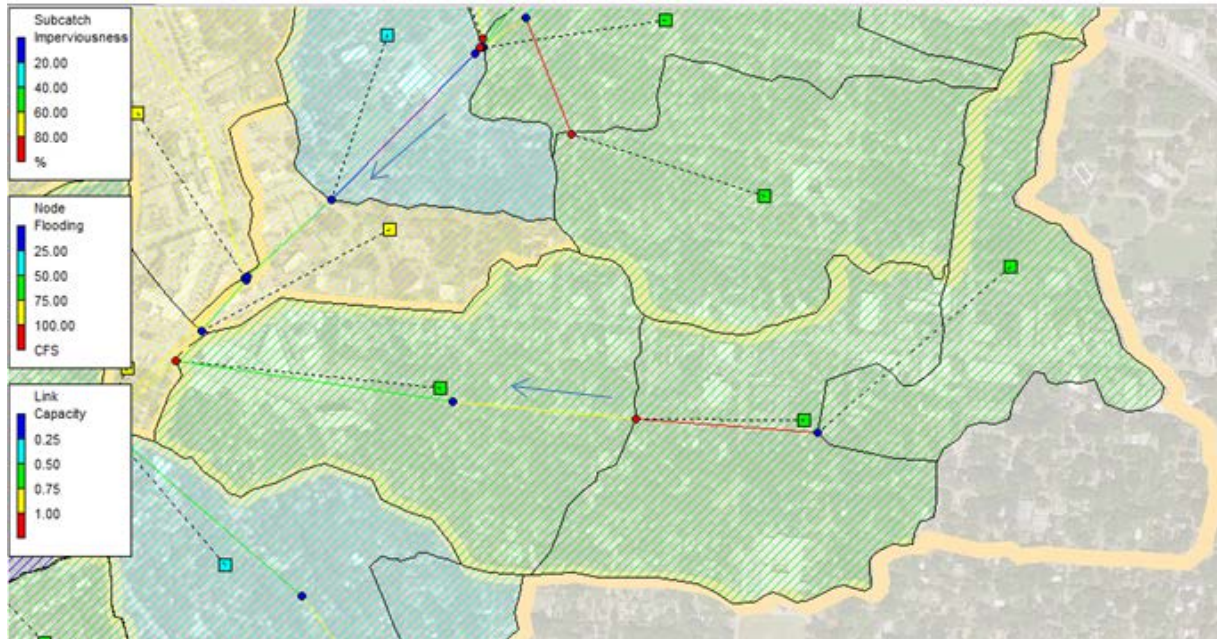
There were no outfalls identified in the DB subwatershed.

#### *SWMM*

Based on the SWMM modeling, the DB subwatershed is estimated to produce approximately 3.7 peak cfs/acre for a typical 2-year storm event. Of the 11 subwatersheds within the watershed, this discharge ranks as ninth highest, indicating the DB subwatershed is on the lower end of peak discharges for the 2-year event. The 192-acre subwatershed is modeled to create approximately 9.1 million gallons of runoff during the 2-year event, approximately the sixth largest contributor in the watershed based on total volume, and 6,353 cubic feet/acre. Its impervious surface is approximately 47%, mid-range among the subwatersheds.

Drainage in the DB subwatershed flows through three modeled subcatchments, and connects underground to the large culverts running through the Five Points area with a 4 foot by 6.5 foot box culvert. In the SWMM model, this line is reaching at least 70% capacity during a 2-year event and some flooding is modeled at its eastern end. Flooding is also modeled where the pipe connects underneath Five Points.

### **Total Subwatershed Runoff Ranking: 6**

**Figure 6.30 DB SWMM Model**








### **Restoration Opportunities**

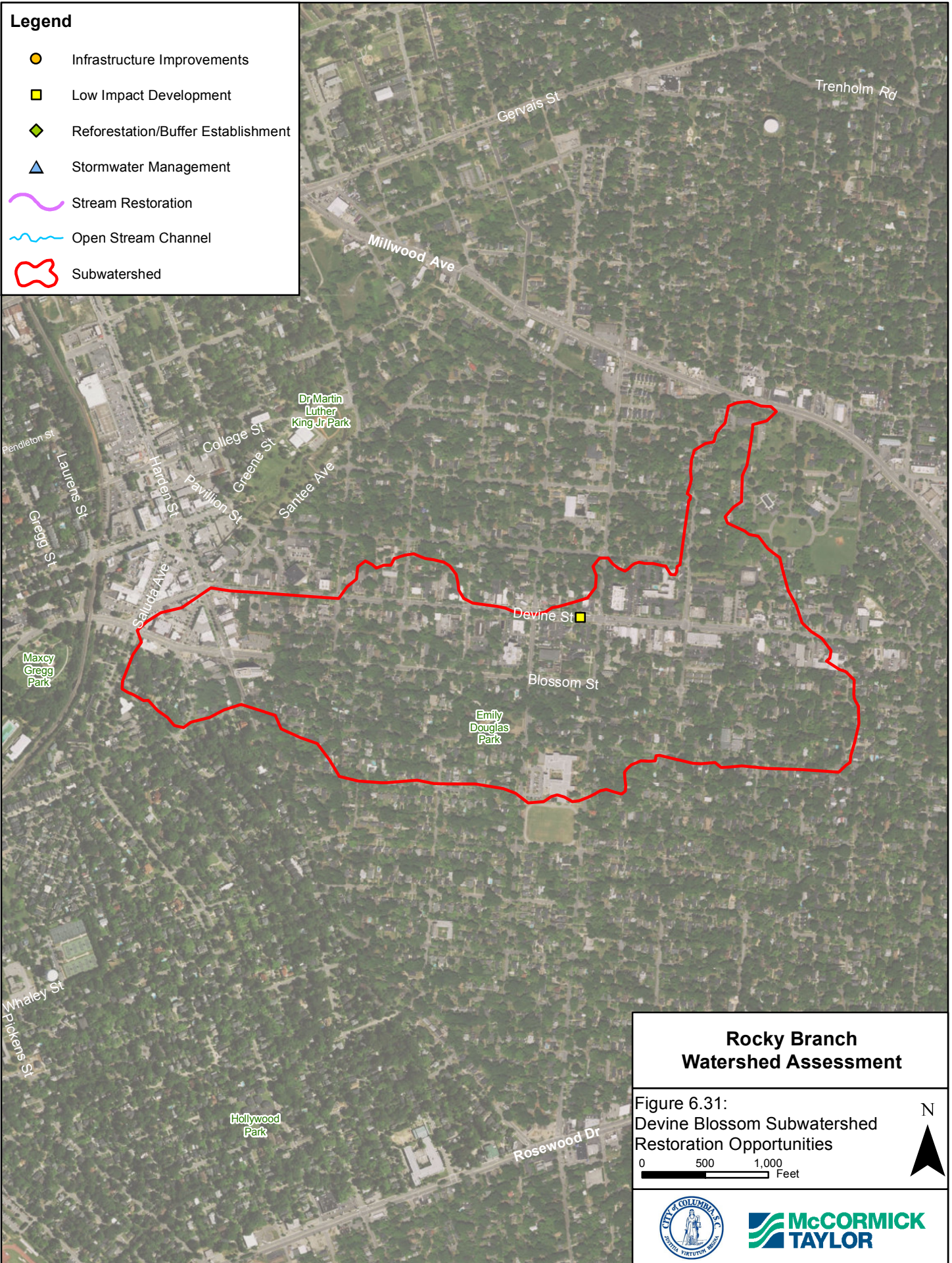
The following projects or similar improvements may be considered to address conditions identified in the DB subwatershed. These projects are included in **Figure 6.31**.

#### **Recommended Improvements:**

- Opportunities for infiltration and storage should be investigated here to reduce peaks downstream.
  - Apply green streets template to reduce runoff from Devine Blossom neighborhood.
- Addition of imperviousness is not recommended for this watershed without storage for excess runoff.
- Determine if the peak of this watershed can be adjusted or lowered to improve conditions in the Five Points area.

**Legend**

-  Infrastructure Improvements
-  Low Impact Development
-  Reforestation/Buffer Establishment
-  Stormwater Management
-  Stream Restoration
-  Open Stream Channel
-  Subwatershed

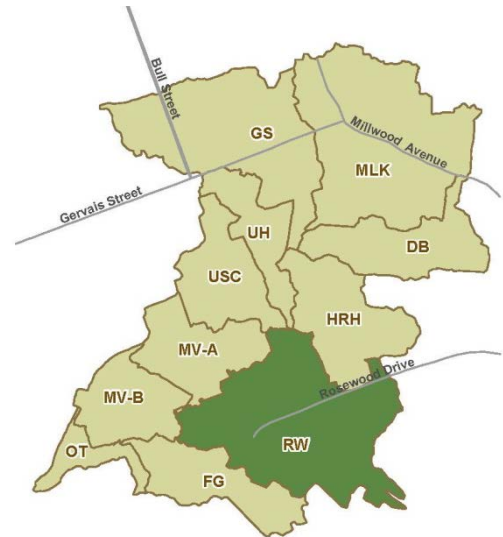


## 6.7 Rosewood (RW) Subwatershed

### Introduction

#### Setting:

- The Rosewood (RW) subwatershed is located to the southeast and is the second largest subwatershed within the Rocky Branch watershed.
- The subwatershed encompasses Capital City Stadium and the USC sports facilities complex. Rosewood Drive intersects the northern boundary along with portions of the Wales Garden and the Hollywood-Rose Hill neighborhoods.
- 489 acres or 0.76 square miles in drainage area
- Contains 1.48 miles of open stream channel, and 5.81 miles of mapped storm drain/pipe
- Dominant land use designations (**Figure 6.1, Table 6.1**):
  - Developed, Medium Intensity: 40%
  - Developed, Low Intensity: 34%
  - Developed, High Intensity: 14%
- Impervious surface cover: 41%



**Figure 6.32 Rosewood Subwatershed**

**Soils:** Approximate soil type percentages within RW subwatershed include (refer to **Section 3.4** for soil descriptions and **Figure 6.33** for soil distributions):

- Lakeland-Urban land complex (LkB): 37%
- Urban land (Ur): 23%
- Orangeburg-Urban land complex, 6 to 15% slopes (OgD): 20%
- Orangeburg-Urban land complex, 2 to 6% slopes (OgB): 13%
- Dothan-Urban land complex, 0-6% slopes (DuB): 7%




#### Overview:

The RW subwatershed is represented by a variety of land uses. The southern region is comprised of commercial lots, a portion of the USC Williams-Brice Stadium parking facility, and the Capital City Stadium. A railroad separates the heavily industrialized area from residential neighborhoods and community buildings. The USC sports facilities complex which includes tennis courts, baseball field, track, and soccer fields is located north of Rosewood Drive. The remaining northeastern portion of the subwatershed is mainly residential with the largest building in this area the AC Moore Elementary School.

### Existing Conditions

**Figure 6.34** highlights existing conditions that were either captured during the stream cruising effort or developed using GIS data.

**Legend**

-  Open Stream Channel
-  Soils
-  Subwatershed



**Rocky Branch  
Watershed Assessment**

Figure 6.33:  
Rosewood Subwatershed  
Soils

0 500 1,000 Feet

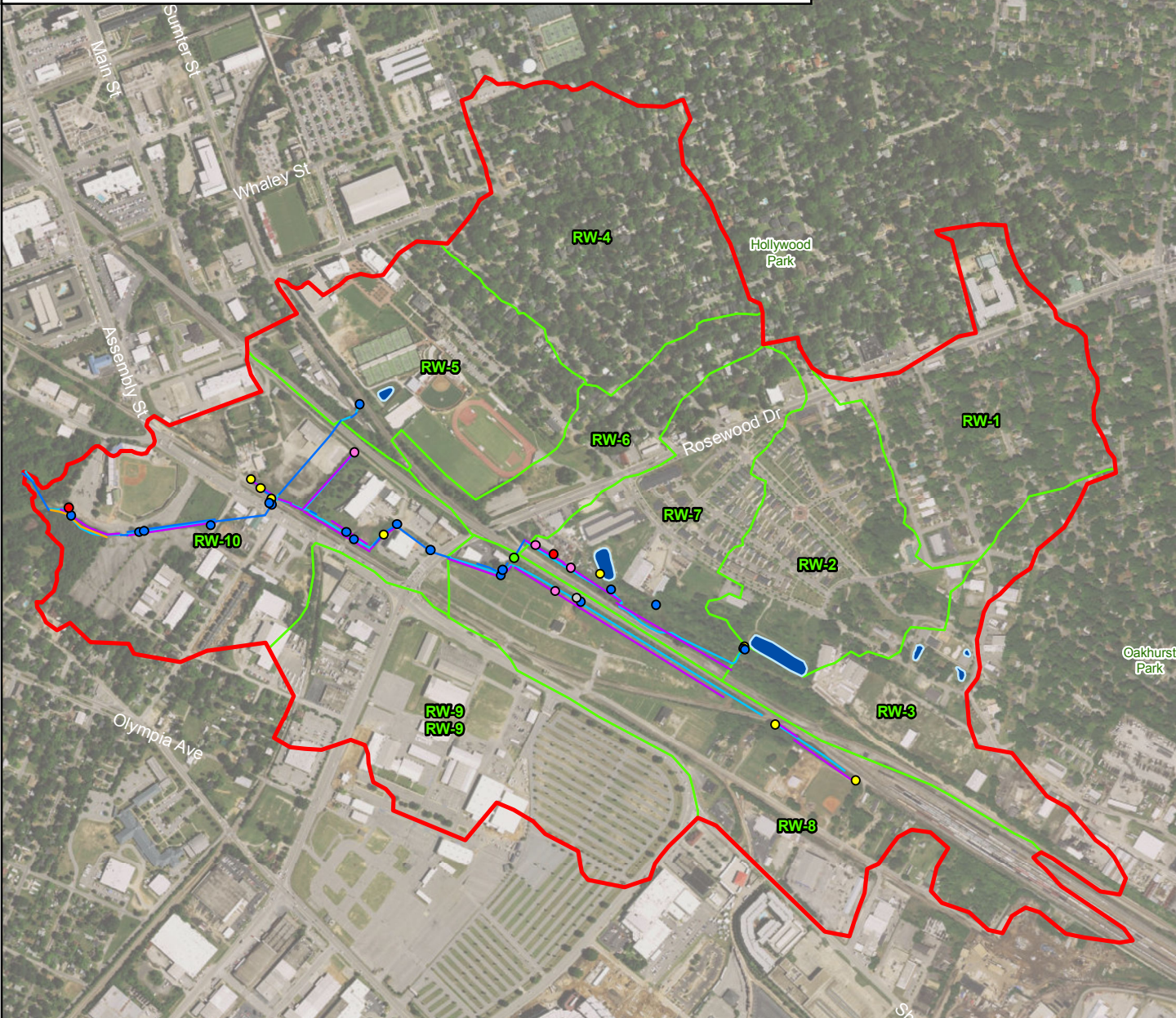
N





**Legend**

- Trash Dumping
- Pipe Outfall
- Near Stream Construction
- Possible Fish Barrier
- Exposed Pipe
- Bedrock
- Unmanaged Runoff
- Unusual Condition
- ~ Open Stream Channel
- Erosion Site
- Channel Alteration
- Inadequate Forest Buffer
- SWM Facility
- SWMM Subcatchment
- Subwatershed





Existing Condition	Count
Exposed Pipes	5
Pipe Outfalls	13
Unmanaged Runoff	1
Unusual Condition	8
Trash Dumping	1
Possible Fish Barrier	0
Linear Feet	
Erosion Site	204
Channel Alteration	625
Inadequate Forest Buffer	2,580

**Rocky Branch  
Watershed Assessment**

Figure 6.34:  
Rosewood Subwatershed  
Existing Conditions

N  
▲

0 500 1,000  
Feet



### Channel Conditions:



The channel network in the eastern portion of the RW subwatershed consists of two drainage swales adjacent to the railroad, one to the north of the railroad and one to the south. The channel on the southern side of the railroad is narrow and vegetated. The left bank is low and adjacent to a field used for overflow parking for the USC stadium. The right bank is limited by the railroad embankment. The channel on the northern side of the railroad is a wetland-like saturated system lacking defined banks for much of its length east of Rosewood Hills Drive. At the point where a second

stormwater pond outlet enters the stream, east of Rosewood Hills Drive, the channel becomes narrower and more defined. There are old, abandoned pipes in the channel bed and trash throughout this section. The banks are low and the bed primarily consists of silt and sand, with some saprolitic clay at the downstream end. The northern channel passes underneath the railroad east of Rosewood Drive and converges with the channel on the southern side of the railroad. It is likely the stream was historically channelized and straightened between the railroad and Rosewood Drive where a business encroaches on the channel from the right bank and the USC overflow parking lot encroaches on the left bank. The stream flows into twin 40 inch pipes at Rosewood and emerges for 20 feet before flowing into twin 48 inch pipes conveying flow underneath a commercial property south of East Broadway Street.

The stream is channelized between roads and businesses in the central region of the watershed. At the upstream end, near Rosewood Avenue, the channel runs between two parking lots; the left bank is defined by a 5-foot tall stone wall stabilizing the edge of the parking lot. The channel then turns to the right, running parallel to the railroad along South Assembly Street. The channel is narrow and pinched between a 5-foot tall railroad embankment on the left and a more gradual slope to a business on the right. The stream passes through two culverts under abandoned road crossings in this segment. A small channel originating from a wetland seep draining from the right bank converges with the main channel downstream of the abandoned road crossings. Two smaller tributaries converge with the main channel before the receiving channel passes underneath South Assembly Street.



The culvert that traverses beneath the railroad north of the Assembly Street and Virginia Street intersection was considered to be in severe condition. The culvert is showing signs of significant degradation with active scouring around and behind the right pipe and heavy debris blocks the left pipe. The pipes have separated at terminal section joints. Soil slumping around these pipes is a severe threat to the railroad embankment that crosses this culvert.



The final open channel segment, in the western part of the subwatershed, is located mostly within the City Stadium parking lot. This area is currently cited as a new Kroger Development. At the upstream end, the stream is confined to a masonry-lined channel that extends between parking lots. There are large sandy deposits in the bed and some vegetation has established along the margins and sand bars. There is one bridge crossing connecting parking lots within the masonry-lined portion. Downstream of the masonry-lined section, the bed and banks become natural

material and there is evidence of channel incision. Both banks are approximately 4-feet high; the left bank is well vegetated and stable, while the right bank is vertically eroded with vegetation mowed to the top of the bank. The bed substrate remains mostly sandy. The natural channel segment extends 430 feet before flowing into a 48 inch pipe. The stream is piped for 215 feet and then the channel is open for 75 feet between the piped segment and the confluence with the mainstem at the watershed boundary.

### *Ecology*

Stream habitat quality is poor throughout the RW subwatershed. Common impairments include lack of riparian buffer, excessive channel alteration, embeddedness, and lack of bed diversity. The only segment that had fair habitat quality was the tributary originating from the wetland seep in the middle of the watershed. This stream had better epifaunal substrate/ available cover and less channel alteration.

The vast majority of the stream channel in RW has an inadequate buffer, with approximately 60% of the banks lacking a vegetated width of at least 35 feet. This is due to the primarily commercial nature of the subwatershed adjacent to the stream channel. The only substantial areas of forest cover are at the eastern end of the watershed north of the railroad, at the center of the watershed east of the wetland seep, and at the eastern end of the watershed south of the City Stadium.

### **Constraints:**

- Property Ownership:
  - Overall RW open channel:
    - Public: 29%
    - Private: 71%
  - Within 50 foot wide open channel buffer:
    - Public: 5%
    - Private: 95%
- Mapped Drainage Network:
  - Drain Pipe: 80%
  - Open Stream Channel: 20%
- 10 longitudinal channel interruptions
- Channel encroachment: parking lots, commercial buildings, park facilities, railroad



## **SWM Assessment:**

### *Facilities*

The RW subwatershed has the highest number of mapped SWM facilities per subwatershed within the Rocky Branch watershed at six sites. The westernmost BMP is a detention pond located adjacent to the USC Beckham Field. The second SWM facility is located off Superior Street adjacent to City Garage and Body Shop. The third BMP within the RW subwatershed is southeast of the pervious facility, between Superior Street and the railroad. The remaining three SWM facilities are located within Edisto Discovery Park.

### *Outfalls*

A total of 18 outfalls were noted within the RW subwatershed during the stream cruising walk, three of which were determined to be in severe condition. Two outfalls in severe condition contribute flow to the open stream channel north of the Assembly Street, Virginia Street intersection. The grade at which the western outfall is positioned allows baseflow from the mainstem to drain into the pipes. The severity of these pipes is also indicative of the complexity in drainage confluence at this point where cumulative conveyance from upstream appears to be larger than the receiving road culvert downstream. Downstream, an outfall on the southwest side of the City Stadium parking lot has an alignment almost parallel with the main channel and upstream bank erosion threatens to expose the pipe.

### *SWMM*

The RW subwatershed is the second largest subwatershed at 489 acres and occupies the southeastern corner of the watershed. The SWMM model predicts that the subwatershed would produce 4.0 peak cfs/acre for a 2-year storm event, which is below the watershed average of 4.5 peak cfs/acre. This moderate value may be due to a lower than average impervious surface value of 41%. With its size, the RW subwatershed is predicted to produce 20.1 million gallons of runoff during a 2-year storm event, which is the third highest amount within the watershed, and 5,489 cubic feet/acre of runoff, which is the eighth lowest value. Given these values, this subwatershed received a moderate subwatershed runoff ranking of 7.

The RW subwatershed was modeled as 10 subcatchments draining through two primary routes to a central drainage canal. There is a pond modeled in one of the subcatchments that collects water from the Rosewood Hills Neighborhood. The pipes and channels coming from the northern side of the subwatershed down are at much higher capacity (over 80%) at the 2-year event than the ditch system conveying water east to west. There is little flooding modeled in the RW subwatershed during a 2-year event.

**Total Subwatershed Runoff Ranking: 7**

**Figure 6.35 RW SWMM Model**








### Restoration Opportunities

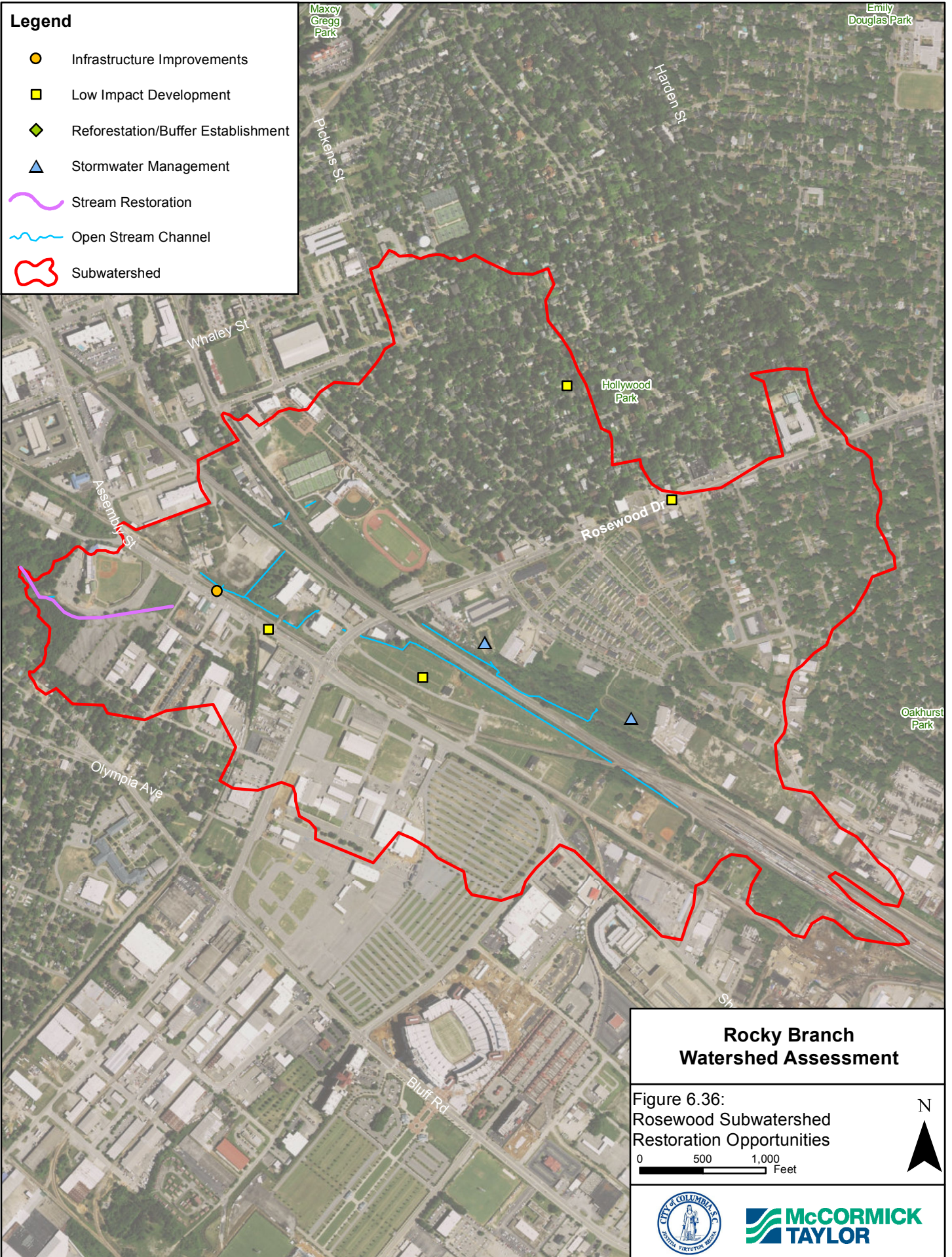
The following projects or similar improvements may be considered to address conditions identified in the RW subwatershed. These projects are included in **Figure 6.36**.

#### **Recommended Improvements:**

- Opportunities for infiltration and storage should be investigated here to reduce runoff and peaks downstream.
  - Install a bioretention area or sand filters to the Olympia Learning Center, State Fairgrounds parking and overflow parking facility for USC complex
  - Add tree boxes with underground detention cells to Rosewood Drive and Assembly Street
  - Retrofit the ponds off Superior Street to prevent short-circuiting
- Replace culvert at Assembly Street west of Rosewood Street with an adequate sized structure. Stabilize stream channel and headcut upstream of culvert.
- Addition of imperviousness is not recommended for this watershed without storage for excess runoff

**Legend**

-  Infrastructure Improvements
-  Low Impact Development
-  Reforestation/Buffer Establishment
-  Stormwater Management
-  Stream Restoration
-  Open Stream Channel
-  Subwatershed



**Rocky Branch  
Watershed Assessment**

Figure 6.36:  
Rosewood Subwatershed  
Restoration Opportunities

0 500 1,000  
Feet

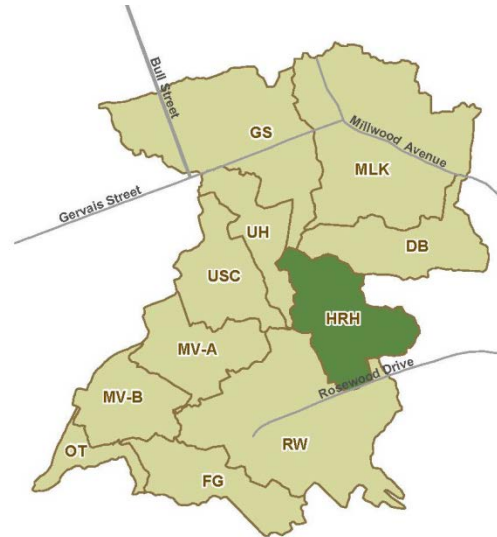


## 6.8 Hollywood-Rose Hill (HRH) Subwatershed

### Introduction

#### Setting:

- The Hollywood-Rose Hill (HRH) subwatershed is centrally located on east side of the Rocky Branch watershed. The UH subwatershed is to the west and the RW subwatershed is to the south of HRH.
- This subwatershed is north of Rosewood Drive and the Hollywood-Rosewood, Wales Garden, and Shandon neighborhoods are located within it.
- 221 acres or 0.35 square miles in drainage area
- Contains no open stream channel and approximately 4.14 miles of mapped storm drain/pipe
- Dominant land use designations (**Figure 6.1, Table 6.1**):
  - Developed, Low Intensity: 58%
  - Developed, Open Space: 33%
- Impervious surface cover: 40%



**Figure 6.37 Hollywood-Rose Hill Subwatershed**

**Soils:** Approximate soil type percentages within HRH subwatershed include (refer to **Section 3.4** for soil descriptions and **Figure 6.38** for soil distributions):

- Orangeburg-Urban land complex, 2 to 6% slopes (OgB): 64%
- Orangeburg-Urban land complex, 6 to 15% slopes (OgD): 34%
- Fuquay-Urban land complex, 0 to 6% slopes (FyB): 1%
- Urban land (Ur): 1%




#### Overview:

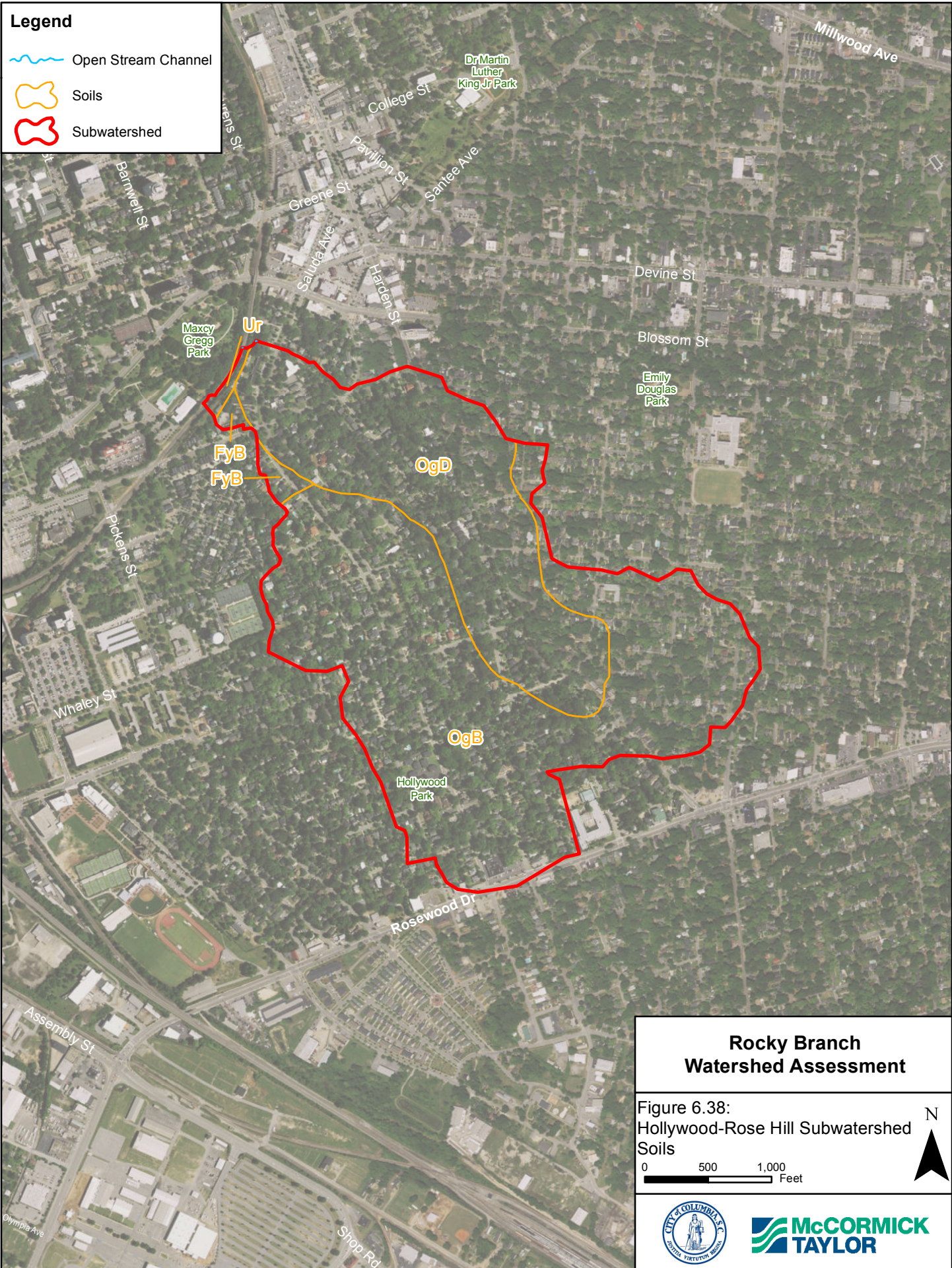
Of the 11 subwatersheds within the Rocky Branch watershed, the HRH subwatershed contains the lowest percentage of commercial and industrial properties. This community is mainly single-family detached homes, with a mature tree canopy, and pedestrian friendly with its incorporation of sidewalks. The southernmost boundary of HRH is at Rosewood Drive between South Edisto Avenue and South Saluda Avenue, which is the most commercial portion of the subwatershed.

### Existing Conditions

**Figure 6.39** highlights existing conditions that were either captured during a stream cruising effort or developed using GIS data.

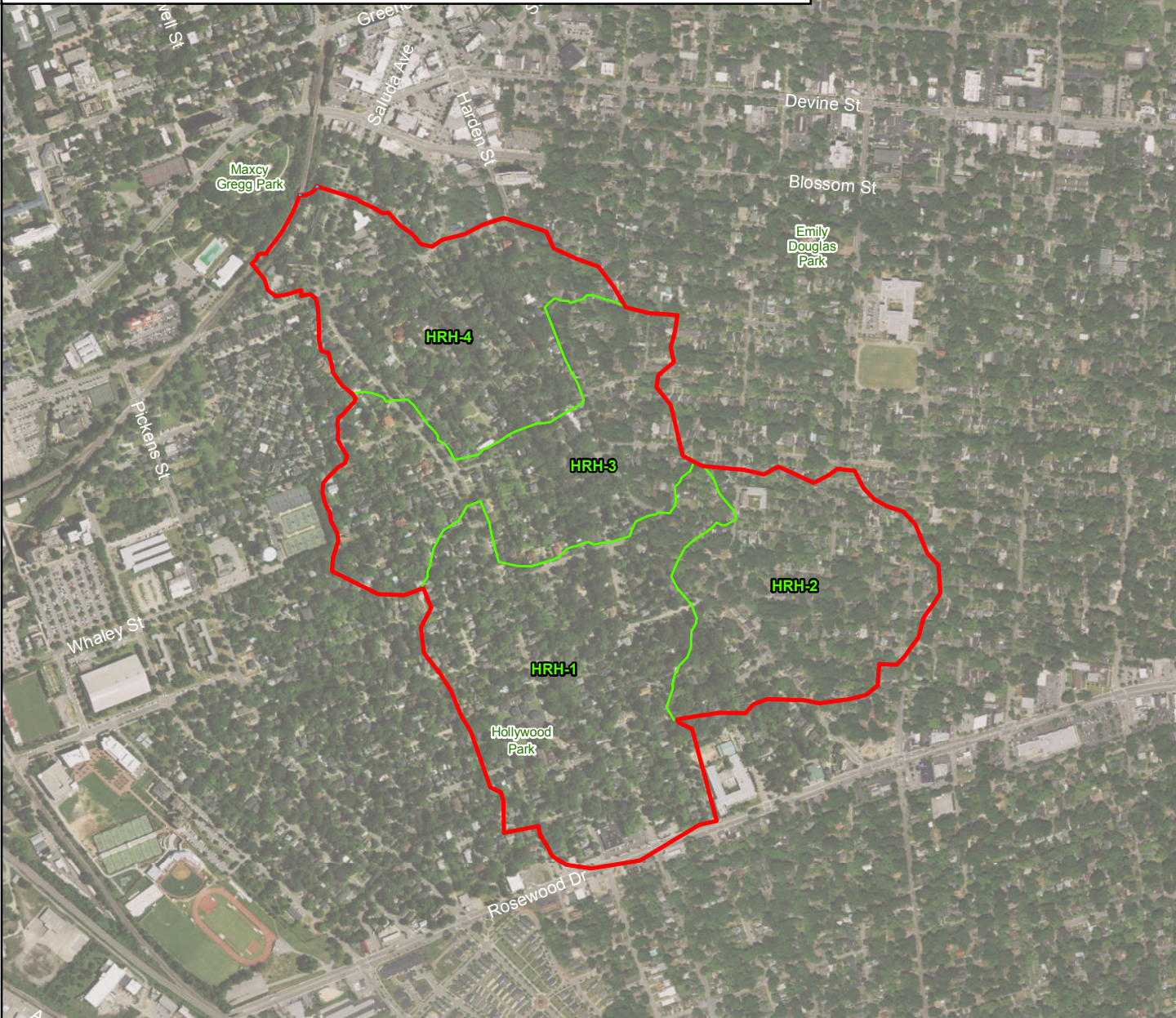
**Legend**

-  Open Stream Channel
-  Soils
-  Subwatershed



**Legend**

- Trash Dumping
- Pipe Outfall
- Near Stream Construction
- Possible Fish Barrier
- Exposed Pipe
- Bedrock
- Unmanaged Runoff
- Unusual Condition
- ~ Open Stream Channel
- Erosion Site
- Channel Alteration
- Inadequate Forest Buffer
- ☾ SWM Facility
- ☾ SWMM Subcatchment
- ☾ Subwatershed



**Rocky Branch  
Watershed Assessment**

Figure 6.39:  
Hollywood-Rose Hill Subwatershed  
Existing Conditions



Existing Condition	Count
Exposed Pipes	0
Pipe Outfalls	0
Unmanaged Runoff	0
Unusual Condition	0
Trash Dumping	0
Possible Fish Barrier	0
Linear Feet	
Erosion Site	0
Channel Alteration	0
Inadequate Forest Buffer	0





---

**Channel Conditions:**

There are no open stream channel segments in the HRH subwatershed.

**Constraints:**

- Property Ownership:
  - Overall HRH open channel:
    - Public: 26%
    - Private: 73%
  - Within 50 foot wide open channel buffer:
    - Public: N/A
    - Private: N/A
- Mapped Drainage Network:
  - Drain Pipe: 100%
  - Open Stream Channel: 0%

**SWM Assessment:**

*Facilities*

There are no mapped SWM facilities located within the HRH subwatershed.

*Outfalls*

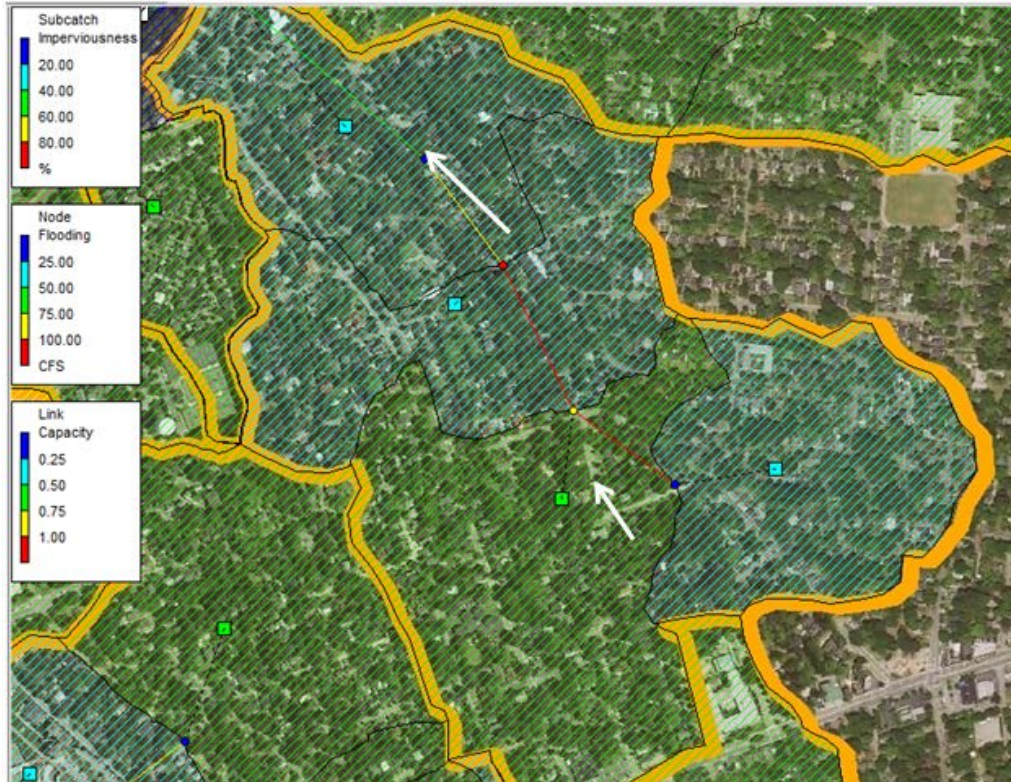
There were no outfalls identified in the HRH subwatershed.

*SWMM*

The HRH subwatershed has a lower than average impervious surface percentage at 40% and a mid-size acreage of 221 acres. Based on the SWMM modeling, a 2-year storm event in this subwatershed would produce approximately 4.2 peak cfs/acre, which is just under the average (4.5 peak cfs/acre) for the watershed. The total runoff predicted for a 2-year storm event is also in the mid-range at 8.9 million gallons, which is ranked seventh within the watershed, and the subwatershed is modeled to produce 5,387 cubic feet/acre.

The HRH subwatershed was modeled as four subcatchments that all ultimately drain to a 72 inch RCP, which outfalls at the same point as the culverts below Five Points. Flooding can be seen in the middle of the subwatershed during the 2-year event, when the trunk lines are at absolute capacity all the way to the final watershed outfall.

**Total Subwatershed Runoff Ranking: 8**

**Figure 6.40 HRH SWMM Model**








### **Restoration Opportunities**

The following projects or similar improvements may be considered to address conditions identified in the HRH subwatershed. These projects are included in **Figure 6.41**.

#### **Recommended Improvements:**

- Opportunities for infiltration and storage should be investigated here to reduce runoff and peaks downstream
  - Apply green streets template to reduce runoff from Hollywood-Rose Hill neighborhood
  - Add tree plantings to Hollywood Park where feasible
- Addition of imperviousness is not recommended for this watershed without storage for excess runoff.

**Legend**

-  Infrastructure Improvements
-  Low Impact Development
-  Reforestation/Buffer Establishment
-  Stormwater Management
-  Stream Restoration
-  Open Stream Channel
-  Subwatershed



**Rocky Branch  
Watershed Assessment**

Figure 6.41:  
Hollywood-Rose Hill Subwatershed  
Restoration Opportunities

0 500 1,000  
Feet



## 6.9 Fairgrounds (FG) Subwatershed

### Introduction

#### Setting:

- Fairgrounds (FG) is the southernmost subwatershed within the Rocky Branch watershed
- This subwatershed spans from the Vulcan Materials mine northwest/downstream to the Williams-Brice Stadium to the southeast
- 171 acres or 0.27 square miles in drainage area
- Contains 0.04 miles of open stream channel, and 0.93 miles of mapped stream drain/pipe
- Dominant land use designations (**Figure 6.1, Table 6.1**):
  - Developed, Medium Intensity: 41%
  - Developed, Low Intensity: 38%
  - Developed, High Intensity: 19%
- Impervious surface cover: 46%



**Figure 6.42 Fairgrounds Subwatershed**

**Soils:** Approximate soil type percentages within FG subwatershed include (refer to **Section 3.4** for soil descriptions and **Figure 6.43** for soil distributions):

- Lakeland-Urban land complex (LkB): 85%
- Urban land (Ur): 15%




#### Overview:

The western portion of this subwatershed is mainly single-family residential with some community buildings and small businesses. Streets are lined with trees and other vegetation and residential lots are widely permeable. Impervious land use increases to the eastern side of the subwatershed. This area incorporates portions of the Williams-Brice Stadium, the SC State Fairgrounds, and the majority of the stadium parking facilities. Although retrofitted to incorporate grassed medians and tree plantings, these large parking lots are paved, impermeable surfaces. GIS data shows no stormwater facilities or drain pipes in the vicinity of this area.

### Existing Conditions

**Figure 6.44** highlights existing conditions that were either captured during the stream cruising effort or developed using GIS data.

**Legend**

-  Open Stream Channel
-  Soils
-  Subwatershed



**Legend**

- Trash Dumping
- Pipe Outfall
- Near Stream Construction
- Possible Fish Barrier
- Exposed Pipe
- Bedrock
- Unmanaged Runoff
- Unusual Condition
- ~ Open Stream Channel
- Erosion Site
- Channel Alteration
- Inadequate Forest Buffer
- SWM Facility
- SWMM Subcatchment
- Subwatershed



**Rocky Branch  
Watershed Assessment**

Figure 6.44:  
Fairgrounds Subwatershed  
Existing Conditions

0 500 1,000 Feet

N

Existing Condition	Count
Exposed Pipes	0
Pipe Outfalls	4
Unmanaged Runoff	0
Unusual Condition	2
Trash Dumping	0
Possible Fish Barrier	0
Erosion Site	0
Channel Alteration	174
Inadequate Forest Buffer	336



### Channel Conditions:



There is minimal open channel length in the FG subwatershed. There is one short section that flows underneath Ohio Street, between Whitney Street and Olympia Avenue. The stream is channelized, located between private properties, and has low, stable banks. The channel bed lacks feature diversity and the substrate includes mostly sand and silt.

### Ecology

The habitat in this stream segment is poor overall. The main habitat impairments observed include embeddedness, lack of riparian buffer, little bed feature diversity, and poor epifaunal substrate/available cover. Approximately 70% of the open channel segment lacks a 35-foot wide or greater riparian buffer, with herbaceous vegetation typically mowed, including portions of the stream banks. Some small shrubs and vines are present along the right bank toward upstream end of the reach.

### Constraints:

- Property ownership
  - Overall FG open channel:
    - Public: 46%
    - Private: 54%
  - Within 50 foot wide open channel buffer:
    - Public: 17%
    - Private: 83%
- Mapped Drainage Network:
  - Drain Pipe: 96%
  - Open Stream Channel: 4%
- One longitudinal channel interruption
- Channel encroachment: residential use

### SWM Assessment:

#### Facilities

There are no mapped SWM facilities located within the FG subwatershed.

## Outfalls

Four outfalls were identified within the FG subwatershed, all of which were considered to be in minor or moderate condition.

## SWMM

The SWMM modeling of existing conditions showed that the FG subwatershed has a simulated 2.8 peak cfs/acre for a typical 2-year storm event, which is the lowest amount for the Rocky Branch Watershed. The 171-acre subwatershed is modeled to create approximately 7.7 million gallons of runoff during the 2-year event, which is also on the lower end for the watershed, and 6,029 cubic feet/acre, which is mid-range for the watershed. The FG subwatershed is approximately 46% impervious, which is just above the average value for the watershed. The lower slopes in this subwatershed likely contribute to less peak discharge being modeled during storm events.

**Figure 6.45 FG SWMM Model**



The FG subwatershed consists of 3 modeled subcatchments. Most of the drainage flows from east to west through a 60 inch RCP. Even though this RCP was determined to outfall into the Vulcan Materials mine, it was modeled as if it is attached to Rocky Branch in order to simulate flows. The line is very close to capacity during the 2-year event, and flooding begins to occur at this point based on the model. The western portion of this subwatershed does not flood until the 10-year event at existing culvert capacities.

**Total Subwatershed Runoff Ranking: 9**



---








## **Restoration Opportunities**

The following projects or similar improvements may be considered to address conditions identified in the FG subwatershed. These projects are included in **Figure 6.46**.

### **Recommended Improvements:**

- Opportunities for infiltration and storage should be investigated here to reduce runoff and peaks downstream.
  - Apply green streets template to reduce runoff from Olympia-Granby neighborhood.
  - Plant trees where feasible in the lot east of Hastings Street and north of Olympia Avenue.
- Field reconnaissance suggests that a large portion of this basin drains into the Vulcan Materials mine through a 60 inch RCP on Georgia Street. The City of Columbia should work with Vulcan to reroute this drainage down Delaware Street. This would also help with flooding problems locally.

**Legend**

-  Infrastructure Improvements
-  Low Impact Development
-  Reforestation/Buffer Establishment
-  Stormwater Management
-  Stream Restoration
-  Open Stream Channel
-  Subwatershed



**Rocky Branch  
Watershed Assessment**

Figure 6.46:  
Fairgrounds Subwatershed  
Restoration Opportunities

0 500 1,000  
Feet

N

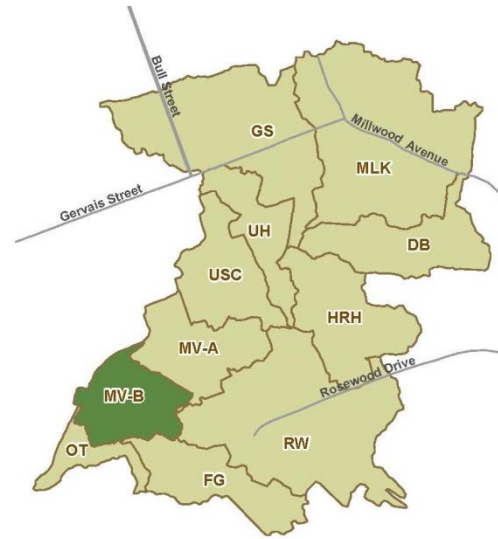


## 6.10 Mill Villages B (MV-B) Subwatershed

### Introduction

#### Setting:

- The Mill Villages B (MV-B) subwatershed is located directly to the northeast of the Outlet (OT) subwatershed.
- The subwatershed extends from Pacific Park at the western end to the Capital City Stadium at the eastern/upstream edge, and to the Vulcan Materials mine to the south/downstream.
- 154 acres or 0.24 square miles in drainage area
- Contains 0.74 miles of open stream channel, and 1.57 miles of mapped storm drain/pipe
- Dominant land use designations (**Figure 6.1, Table 6.1**):
  - Developed, Medium Intensity: 44%
  - Developed, Low Intensity: 34%
- Impervious surface cover: 40%



**Figure 6.47 Mill Villages B Subwatershed**

**Soils:** Approximate soil type percentages within MV-B subwatershed include (refer to **Section 3.4** for soil descriptions and **Figure 6.48** for soil distributions):

- Orangeburg-Urban land complex (OgB): 61%
- Lakeland-Urban land complex (LkB): 31%
- Urban land (Ur): 8%




#### Overview:

This subwatershed is mostly residential with a pocket of businesses to the north. Most residential properties are single-family detached; however, there are two large apartment buildings sitting on 20 acres in the southwest portion of the subwatershed. To the east, multiple single-family attached buildings and Olympia Park. Olympia Park is a small historic park in the Olympia neighborhood providing access to Mill Villages Riverlink, a section of Columbia's Three Rivers Greenway trail.

### Existing Conditions

**Figure 6.49** highlights existing conditions that were either captured during a field effort or developed using GIS data.

**Legend**

-  Open Stream Channel
-  Soils
-  Subwatershed



**Rocky Branch  
Watershed Assessment**

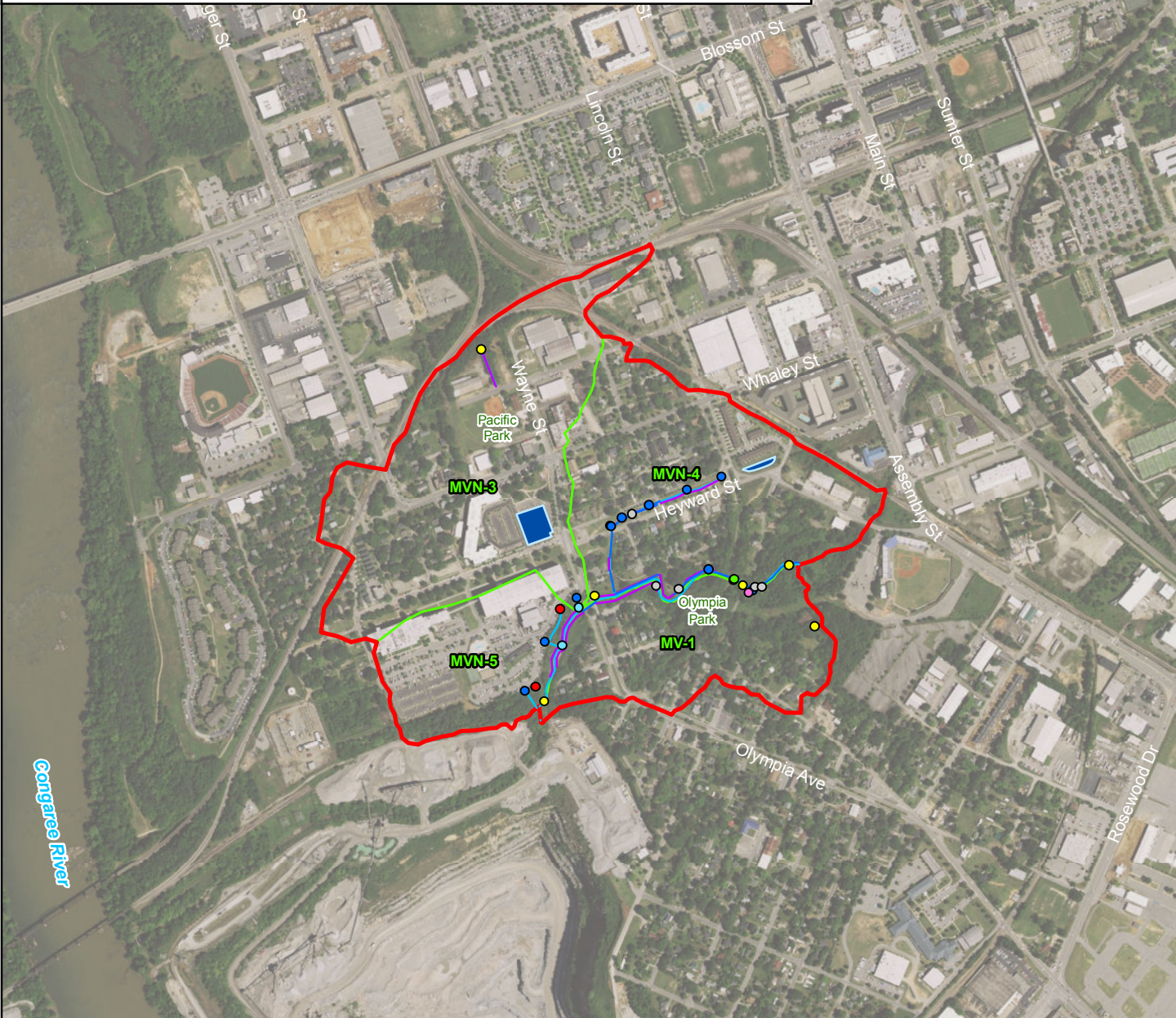
Figure 6.48:  
Mill Villages B Subwatershed  
Soils

0 500 1,000  
Feet



**Legend**

- Trash Dumping
- Pipe Outfall
- Near Stream Construction
- Possible Fish Barrier
- Exposed Pipe
- Bedrock
- Unmanaged Runoff
- Unusual Condition
- Open Stream Channel
- Erosion Site
- Channel Alteration
- Inadequate Forest Buffer
- SWM Facility
- SWMM Subcatchment
- Subwatershed



Existing Condition	Count
Exposed Pipes	5
Pipe Outfalls	13
Unmanaged Runoff	1
Unusual Condition	8
Trash Dumping	1
Possible Fish Barrier	0
Linear Feet	
Erosion Site	204
Channel Alteration	625
Inadequate Forest Buffer	2,580

**Rocky Branch  
Watershed Assessment**

Figure 6.49:  
Mill Villages B Subwatershed  
Existing Conditions

0 500 1,000  
Feet

N

### Channel Conditions:



The MV-B subwatershed channel network begins at the confluence with a tributary on the left bank west of the Capital City Stadium, within a forested parcel. Large broken concrete slabs throughout the channel suggest past channelization and create small cascades within an otherwise sandy bed. The banks are approximately 5 to 7 feet tall and stabilized by the concrete and established vegetation. This segment ends at the culvert underneath Bluff Road.

Downstream of Bluff Road, the channel is open for 50 feet before flowing through a culvert underneath an abandoned railroad. This culvert was considered to be in very severe condition because of slope failure along the railroad embankment on the upstream side of the culvert. The segment downstream of the railroad is within Olympia Park. The right bank has been stabilized with riprap at the upstream end. There is a utility right of way with power lines that cross the stream 250 feet downstream of the abandoned railroad culvert. The bed consists of large deposits of sand, exposed bedrock outcroppings, and some riprap.



The stream is then conveyed through a road culvert at Olympia Avenue; the culvert was considered to be in very severe condition because of damage to the upstream headwall with the brick facade missing on the left side. There is a large scour hole immediately downstream of the Olympia Avenue culvert. The downstream channel segment has large sand and gravel deposits and an exposed sanitary line spanning over the mainstem supported by concrete and brick piers within the active bed. The stream runs between a parking lot for the Granby Apartments on the right bank and a utility right of way on the left.



A small tributary converges with the mainstem on the right bank 130 feet upstream of Olympia Avenue. The tributary begins at a stormwater pond at the northeast corner of Heyward and Lincoln Street and continues downstream through a mowed grass swale in the median of Heyward Street. Within the median, the channel banks are low and stable and the channel bed is mostly sand. The channel is then piped into the mainstem at Olympia Park, with a small 80-foot open channel segment adjacent to the Olympia Park playground.

There is an isolated segment of perennial channel at the northwestern edge of the subwatershed, confined between two commercial properties at the northwest corner of Catawba and Wayne



Street. The channel is narrow, with low, stable banks and the bed substrate primarily consists of gravel.

### *Ecology*

Stream habitat quality ranges from poor to barely fair throughout the MV-B subwatershed. The upstream extents of the Rocky Branch mainstem have stable banks and a wide riparian buffer, though the reach is impacted by extensive channel alteration, sediment deposition, and embeddedness. The reach within Olympia Park and downstream of Olympia Avenue has similar sedimentation issues, though less channel alteration and a narrower riparian buffer. The segment within the median of Heyward Street provides the lowest quality habitat in the subwatershed; it functions more as a drainage swale than a stream system even though it appears to carry perennial flow. The isolated segment to the northwest has less channel alteration and more vegetative protection than the other stream segments, though similar sedimentation issues. Downstream, an odor was apparent during the field assessment, with a bright green substrate film, and white-yellow foam collecting on the water's surface.

Over half of the open channel segments (59%) within the MV-B subwatershed lack a riparian buffer of 35 feet or greater. The upstream extent has the most established vegetated riparian zone, with mature trees and an established understory. The left bank within Olympia Park and the downstream extent also have an adequate riparian buffer.

### **Constraints:**

- Property Ownership:
  - Overall MV-B open channel:
    - Public: 29%
    - Private: 71%
  - Within 50 foot wide open channel buffer:
    - Public: 52%
    - Private: 48%
- Mapped Drainage Network:
  - Drain Pipe: 68%
  - Open Stream Channel: 32%
- Five longitudinal channel interruptions
- Channel encroachments: railroad, parks and recreation areas, residential development

### **SWM Assessment:**

#### *Facilities*

Within the MV-B subwatershed, two SWM facilities are mapped within the City's GIS data. A field review of the first location at Heyward Street and Wayne Street proves to be a parking lot. It is possible this may be a location of an underground BMP. The second SWM facility is located at Lincoln Street and Heyward Street.

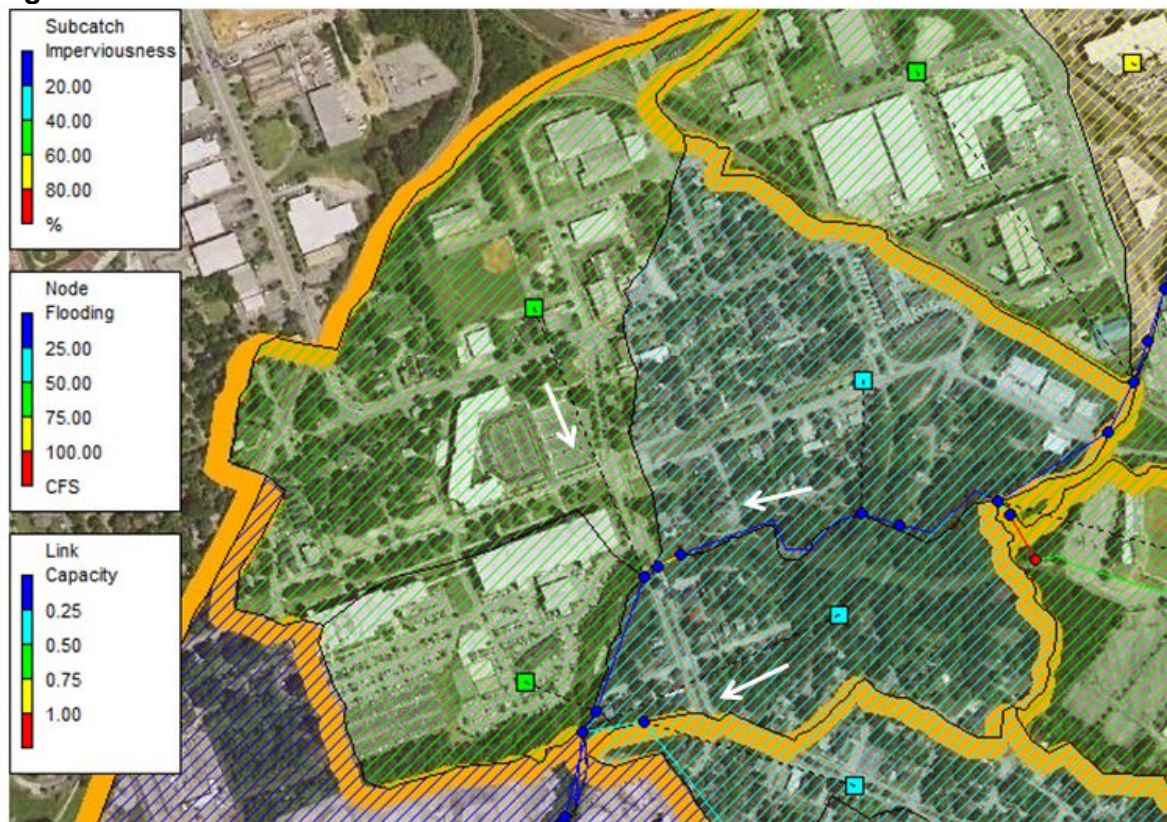
### Outfalls

Ten outfalls were identified within the MV-B subwatershed during the field investigation. One outfall was considered to be in severe condition, located northwest of the Olympia Avenue, Alabama Street intersection. The channel is incised and instability at the head of the channel, and water quality discharging into the mainstem is poor. The outfall is overgrown with roots, vines, and other vegetation, and overland flow enters the head of the channel from multiple directions, including unmanaged runoff from Olympia Avenue.

### SWMM

The MV-B subwatershed is adjacent and to the south of MV-A. MV-B has almost 15% less impervious surface than its northern counterpart and the second lowest impervious value for the watershed. With its smaller size of 154 acres, the MV-B subwatershed is modeled with SWMM to produce only 6.1 million gallons of runoff for a 2-year storm event, the tenth lowest amount for the watershed. The runoff per area is also low at 5,283 cubic feet/acre. The discharge per acre for the 2-year event is in the mid-range at 4.3 peak cfs/acre. Due to these attributes, the MV-B subwatershed received the second lowest subwatershed runoff ranking.

**Figure 6.50 MV-B SWMM Model**





The MV-B subwatershed was modeled as four subcatchments in SWMM. The flows from these subcatchments are linked directly to Rocky Branch, so the model does not indicate any flooding is occurring in the subcatchments as a result of overburdened drainage pipes. Portions of this subwatershed are within the 10-year floodplain for Rocky Branch.

### **Total Subwatershed Runoff Ranking: 10**








#### **Restoration Opportunities**

The following projects or similar improvements may be considered to address conditions identified in the MV-B subwatershed. These projects are included in **Figure 6.51**.

#### **Recommended Improvements:**

- Opportunities for infiltration and storage should be investigated here to reduce runoff and peaks downstream.
  - Install a bioretention area or sand filter to the Granby Mills Student Housing, Olympia Park, Catawba and Wayne Streets, and the median of Heyward and Lincoln Streets.
- Remove the old pipe supports and other low-flow obstacles from the railroad crossing upstream of Olympia Avenue. In addition, upgrade the culvert to dual 10 foot by 12 foot culverts; it currently is modeled as producing a backwater in existing conditions at a 2-year storm event.
- Upgrade the crossing at Olympia Avenue to dual 10 foot by 10 foot culverts. The old brick culvert is degraded and undersized for the location; the structure is modeled to create a backwater in existing conditions at a 2-year storm event.
- Remove the former railroad bridge downstream of Olympia Avenue and restore the channel to a natural condition.
- Replace the sanitary line that crosses the channel west of Olympia Avenue.
- Restore the segment of mainstem Rocky Branch between Bluff and Dreyfuss Road.
- Addition of imperviousness is not recommended for this watershed without storage for excess runoff.

**Legend**

-  Infrastructure Improvements
-  Low Impact Development
-  Reforestation/Buffer Establishment
-  Stormwater Management
-  Stream Restoration
-  Open Stream Channel
-  Subwatershed



**Rocky Branch  
Watershed Assessment**

Figure 6.51:  
Mill Villages B Subwatershed  
Restoration Opportunities

0 500 1,000  
Feet



## 6.11 Outlet (OT) Subwatershed

### Introduction

#### Setting:

- Outlet (OT) subwatershed is the southwestern most subwatershed within the Rocky Branch watershed and includes the confluence with the Congaree River
- Situated to the north and northeast of the Vulcan Materials mine
- 63 acres or 0.10 square miles in drainage area
- Contains 0.62 miles of open stream channel, and 0.01 miles of mapped storm drain/pipe
- Dominant land use designations (**Figure 6.1, Table 6.1**):
  - Barren Land: 42%
  - Developed, Low Intensity: 25%
  - Developed, Medium Intensity: 13%
- Impervious surface cover: 11%



**Figure 6.52 Outlet Subwatershed**

**Soils:** Approximate soil type percentages within OT subwatershed include (refer to **Section 3.4** for soil descriptions and **Figure 6.53** for soil distributions):

- Urban land (Ur): 54%
- Orangeburg-Urban land complex (OgB): 33%
- Lakeland-Urban land complex (LkB): 10%
- Toccoa loam (To): 3%




#### Overview:

The OT subwatershed is primarily industrial land use. The majority of the area is a mine site operated by Vulcan Materials. This area has been a sand and gravel mine for the past 100+ years; over that time Rocky Branch has been relocated numerous times. A large power station is situated at the northwest portion of the subwatershed and is adjacent to a railroad extending along the Rocky Branch watershed boundary. A small strip of vegetation buffers perimeter sections of the mine from single-family residential housing to the northeast and the southeast of the subwatershed.

### Existing Conditions

**Figure 6.54** highlights existing conditions that were either captured during the stream cruising effort or developed using GIS data.

**Legend**

-  Open Stream Channel
-  Soils
-  Subwatershed



**Rocky Branch  
Watershed Assessment**

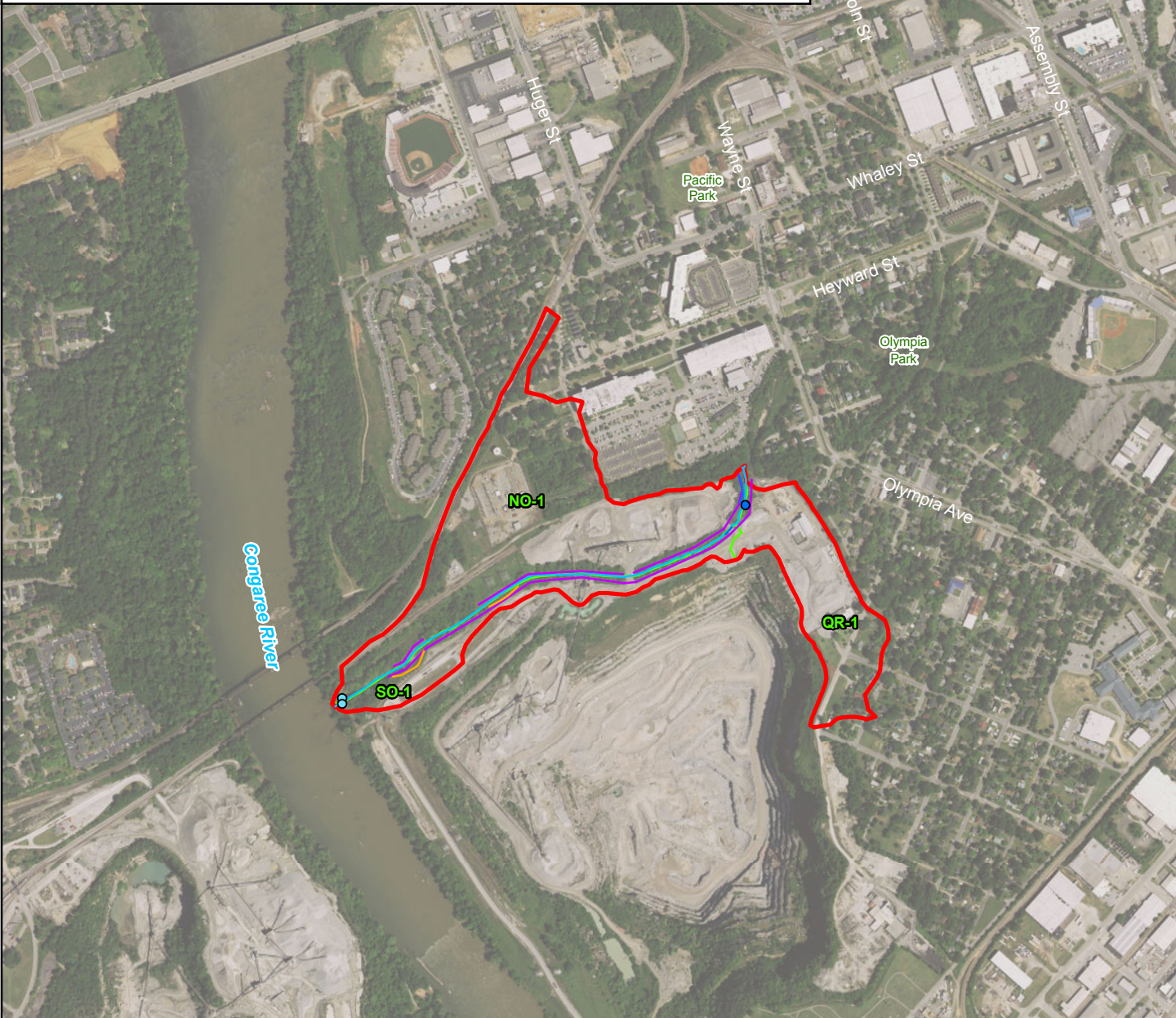
Figure 6.53:  
Outlet Subwatershed  
Soils

0 500 1,000  
Feet



**Legend**

- Trash Dumping
- Pipe Outfall
- Near Stream Construction
- Possible Fish Barrier
- Exposed Pipe
- Bedrock
- Unmanaged Runoff
- Unusual Condition
- ~ Open Stream Channel
- Erosion Site
- Channel Alteration
- Inadequate Forest Buffer
- SWM Facility
- SWMM Subcatchment
- Subwatershed





Existing Condition	Count
Exposed Pipes	2
Pipe Outfalls	1
Unmanaged Runoff	0
Unusual Condition	0
Trash Dumping	0
Possible Fish Barrier	0
	<b>Linear Feet</b>
Erosion Site	509
Channel Alteration	236
Inadequate Forest Buffer	5,065

**Rocky Branch  
Watershed Assessment**

Figure 6.54:  
Outlet Subwatershed  
Existing Conditions

N  
▲

0 500 1,000  
Feet

### Channel Conditions:



The channel network within the OT subwatershed begins along the Rocky Branch mainstem at the northern edge of the mine. Both banks are influenced by the mine throughout this segment, leading to steep banks and channel encroachment. There are two stretches of severe erosion where the channel traverses through the mine. The upstream instance of bank erosion is underneath overhead transmission lines and banks are raw and 30 to 35 feet tall. There are several bridges and utility crossings that span the channel. The channel is generally incised, with bank heights up

to 40 feet as it approaches the Congaree River. Throughout this segment, the channel substrate is mainly defined by steep vegetated banks with locations of riprap slumping off the banks and sand deposition in the pools. The downstream 400 feet of the channel segment is influenced at baseflow by the backwater from the confluence with the Congaree River.

### *Ecology*

Stream habitat quality throughout this segment is mostly fair, with decreasing impairment towards the upstream limit and poorer conditions observed near the confluence with the Congaree River. Embeddedness and heavy sediment deposition are common issues within the stream bed, while lack of vegetative protection on the banks and little to no riparian buffer is impacting overall bank stability. The backwater conditions at the mouth of Rocky Branch have created a deep pool with a thick layer of deposited sand and silt within the bed, greatly reducing the quality of the habitat in this segment.

The narrow stream valley and proximity to the mine and railroad has limited space available for a riparian buffer, though there are small pine trees growing on the steep banks in some locations. Approximately 80% of the stream banks were observed to be lacking a 35-foot or greater riparian buffer width. Some portions of the right bank at the downstream limits of the reach and on the left bank at the mouth of Rocky Branch had an adequate vegetated width.

### Constraints:

- Property Ownership:
  - Overall OT open channel:
    - Public: 0%
    - Private: 100%
  - Within 50 foot wide open channel buffer:
    - Public: 0%
    - Private: 100%
- Mapped Drainage Network:
  - Drain Pipe: 2%
  - Open Stream Channel: 98%
- Two longitudinal channel interruptions



- Channel encroachments: railroad, private property
- Potentially upsetting dormant contaminants from mining

**SWM Assessment:**

*Facilities*

There are no mapped SWM facilities located within the OT subwatershed.

*Outfalls*

Only one outfall was identified during a field review in the OT subwatershed. This outfall was observed to be in moderate condition.

*SWMM*

The OT subwatershed is unique in that it occupies the very downstream limit of the watershed and is comprised of only 63 acres. With 11% impervious surface, the OT subwatershed is the lowest within the watershed. As a result, the values from the SWMM model for a 2-year event also place the OT subwatershed in the lower end: the subwatershed is modeled to produce 3.3 peak cfs/acre, the lowest overall in the watershed, and 1.1 million gallons of runoff, the second smallest amount in the watershed. The runoff per area is also modeled as the smallest value in the watershed at 2,387 cubic feet/acre. These existing conditions give the OT subwatershed the highest (least impaired) runoff ranking in the watershed and indicate that has the lowest relative need of hydraulic improvement in the Watershed.

**Figure 6.55 OT SWMM Model**





The OT subwatershed was modeled as three subcatchments in SWMM. The flows from these subcatchments are linked directly to the Rocky Branch mainstem. Most of the OT subwatershed is within the Vulcan Materials mine.

**Total Subwatershed Runoff Ranking: 11**








**Restoration Opportunities**

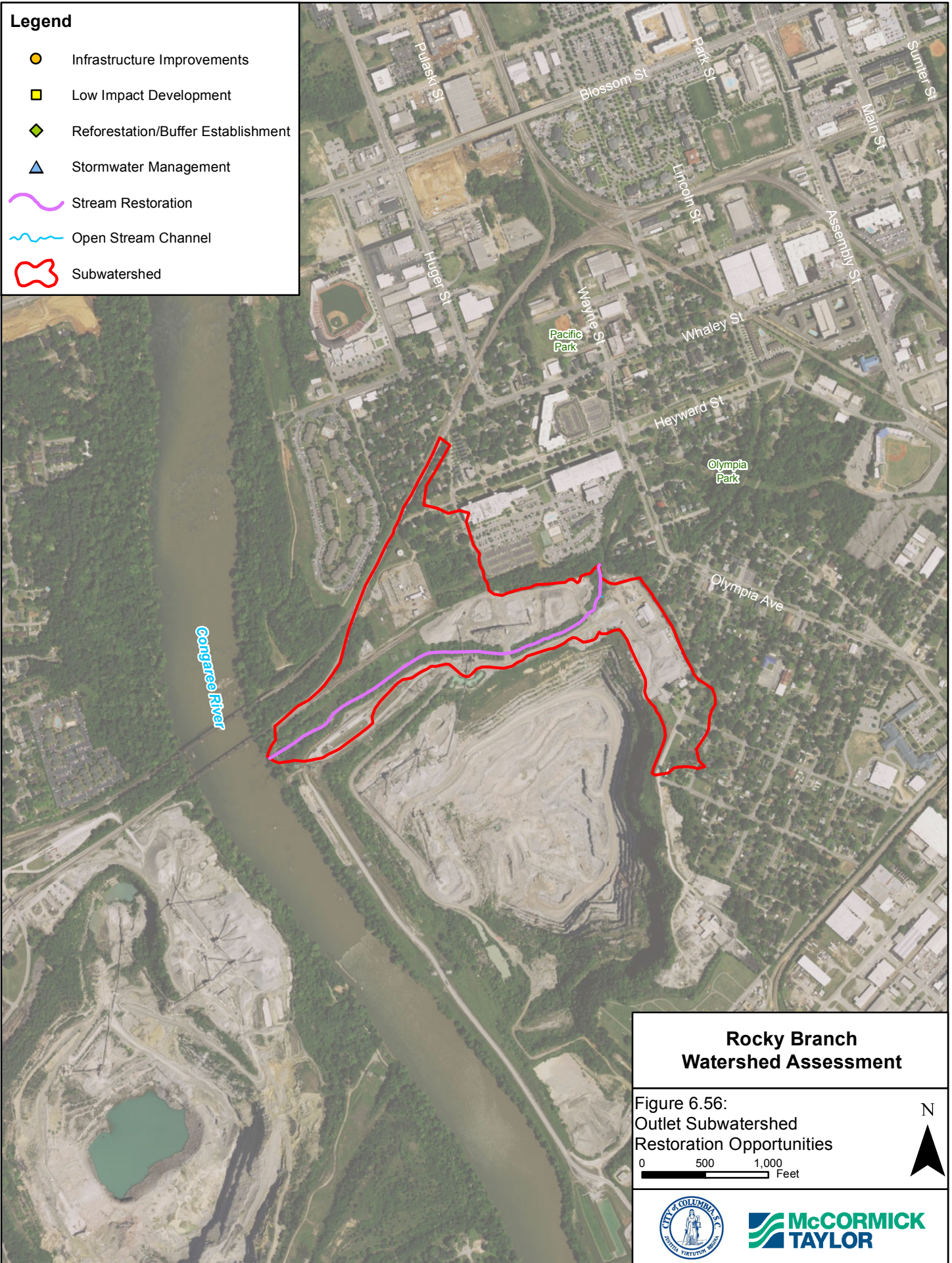
The following projects or similar improvements may be considered to address conditions identified in the OT subwatershed. These projects are included in **Figure 6.56**.

**Recommended Improvements:**

- Restore the mainstem Rocky Branch that is inside the Vulcan Material mine. Mine closure is anticipated for 2030, after which the reach should be restored for the entire length.

**Legend**

-  Infrastructure Improvements
-  Low Impact Development
-  Reforestation/Buffer Establishment
-  Stormwater Management
-  Stream Restoration
-  Open Stream Channel
-  Subwatershed



**Rocky Branch  
Watershed Assessment**

Figure 6.56:  
Outlet Subwatershed  
Restoration Opportunities

0 500 1,000  
Feet

N





## 7.0 Restoration Strategies

This chapter presents an overview of the key restoration strategies proposed for improving the water quality and flood-prone conditions of the Rocky Branch watershed. A complete list of actions proposed for the watersheds including goals and objectives targeted, performance measures, and cost estimates is included in **Section 8.0**. Although only key, quantifiable restoration strategies are the focus of this chapter, it is important to remember that a combination and variety of restoration practices, from capital stream restoration projects or stormwater BMP retrofits, to public education and outreach, are needed to engage citizens and meet watershed-based goals and objectives.

The restoration of the Rocky Branch watershed will occur as a partnership between the local government (City of Columbia and Richland County), watershed groups (Rocky Branch Watershed Alliance and Sustainable Midlands), businesses, and citizens. The actions of each partner are critical to the success of the overall watershed restoration strategy. Local governments are able to implement large capital projects such as culvert/bridge replacements, large-scale stormwater retrofits, stream restoration, changes in municipal operations, and large-scale public awareness. Watershed groups and citizens are able to implement locally-based programs such as tree plantings, storm drain marking, and downspout disconnection. Therefore, key restoration strategies are divided into two broad categories: municipal and institutional strategies (**Section 7.1**) and citizen-based strategies (**Section 7.2**). It is important that restoration occurs at all levels to ensure that a wide range and variety of projects is implemented. This will encourage citizen participation and awareness, which is also critical to the success of restoration efforts.

### 7.1 *Municipal and Institutional Strategies*

The City of Columbia and Richland County are actively working to improve the conditions of their watersheds, receiving streams and improve water quality through capital improvement projects and municipal management activities (e.g. development review, buffer zone implementation, sanitary sewer upgrades, etc.). This plays an important role in the application of this Integrated Watershed Management Plan implementation process. Key municipal strategies proposed for improving the conditions of the Rocky Branch Watershed are discussed in the following sections.

Increased importance of water quality and water resource protection has led to the development of the 2014 City of Columbia Best Management Practice (BMP) Design Manual, which provided BMP design standards and environmental incentives. Rocky Branch is considered a vital water resource for the City and because of this has additional criteria which have to be met. The additional water quality criteria for this watershed include the following items:

- All sites which disturb greater than one acre shall have a post construction water quality BMP in place to treat at least the runoff from the entire site for a 1.2 inch rainfall event.
- All sites which disturb greater than one acre shall have a post construction channel protection volume (CPv) BMP in place to treat at least the runoff from the entire site for a 1-year storm event.
- Pretreatment device shall be provided prior to any BMP



- Developments with commercial land use or a parking lot which exceeds 2,000 square feet must include the ability to capture hydrocarbons either in pretreatment or in the main BMP.
- If it is impractical to route all impervious areas to a BMP, an exemption may be sought, however, the volume must still be stored within the facility.
- All discharge points shall include energy dissipation features.

Additional details on these increased water quality criteria may be found within the 2014 Design Manual, Section 1.2.3 Critical Water Bodies. Additionally, if the site discharges to an impaired water body that is on SCDHEC's 303(d) list additional measures must be taken. For sites less than 25 acres, evaluation of the BMPs chosen to control pollution must be provided. For sites greater than 25 acres, a comprehensive quantitative and qualitative analysis must be provided. This would include determining the sites pollutant loading, effectiveness of the chosen BMPs and insurance that runoff discharged through the last water quality BMP has a water quality level equal to or better than the in-stream standard.

The 2014 guidelines reflect the general shift towards adopting low-impact practices that mimic natural hydrologic processes and achieve pre-development conditions. The 2014 City of Columbia Best Management Practice (BMP) Design Manual takes those principles one step further through the implementation of Better Site Planning to the maximum extent practicable via nonstructural BMPs and/or other better site design techniques. The intent of better site planning is to distribute flow throughout a development site and reduce stormwater runoff leaving the site. This will also reduce pollutant loads and prevent stream channel erosion.

All development within the City that require a land disturbing permit are required to provide water quality BMPs to treat either the 0.60 inch rainfall event for wet pools or the 1.2 inch rainfall event for BMPS without a permanent pool. Additionally Overbank Flood Protection requires that the post development 2-year and 10-year, 24 hour storm peak discharge rates do not exceed pre-development conditions. For sites over 40 acres, 25-year peak management is required. Watersheds that experience flooding may have additional requirements placed on them such as reducing the post development peak discharge to 50% of the pre-development rates, establishment of 100-year flood plain restrictions or a detailed analysis to determine the impact on the altered timing of the stormwater discharges. 100-year, Extreme Flood Protection is required in to be considered in all cases.

Existing stormwater management facilities within the watershed appear to be limited. During the stream cruise approximately seven facilities were located. These facilities were generally dry detention basins. Water quality benefit from these types of facilities is limited and not ideal. Underground facilities may be present within the watershed but were not able to be field identified.

### 7.1.1 Stormwater Retrofits

Stormwater retrofits involve implementing BMPs in existing developed areas where SWM practices do not currently exist to help improve water quality. Stormwater retrofits improve water quality by capturing and treating runoff before it reaches receiving water bodies. Based on initial field and desktop evaluations, there are many sites with sufficient space for stormwater retrofits to treat runoff from buildings, athletic fields, residential areas, impervious parking lots or roadways. Retrofits may only consist of water quality treatment, or include channel

protection, 2-year, or even larger peak discharge management. The type of retrofit is dependent upon the available space, type of property, and cost limitations. In considering the type of retrofit, consideration to the affect it will have on the timing of the peak along Rocky Branch should be considered. While there is a benefit to delay the upland area peak so that it may fall behind the lower main stem peak, if implementation of retrofit BMPs within the lower basin subwatersheds result in a delayed peak, flooding may actually be worsened. Retrofit sites were located in all four upland components surveyed: neighborhoods, publicly owned, institutions, and commercial areas as well as each subwatershed. This study has grouped retrofit opportunities into five categories:

1. Low Impact Design (LID)
2. SWM Facility
3. Stream Restoration
4. Reforestation/Buffer Establishment
5. Infrastructure Improvement

#### **7.1.1.1 Low Impact Design**

##### **7.1.1.1.1 Impervious Cover Removal**

Impervious surfaces include roadways, parking lots, roofs, and other paved surfaces that prevent precipitation from naturally seeping into the ground. As a result, impervious surface runoff can result in erosion, flooding, habitat destruction, and increased pollutant loads to receiving water bodies. Subwatersheds with higher amounts of impervious cover are more likely to have degraded stream systems and contribute significantly to water quality problems in a watershed. Removing impervious cover and converting to pervious or forested land promotes infiltration of runoff and reduces pollutant loads. Unused or unmaintained impervious surfaces with the potential for removal were identified at several institutions, mostly on school properties. The areas of these impervious surfaces were used to estimate potential pollutant load reductions as a result of impervious cover removal activities.

##### **7.1.1.1.2 Bioretention and Rain Gardens**

These facilities have many water quality benefits such as filtration of pollutants from runoff, recharging groundwater supply, and reducing total runoff and flooding potential. Bioretention and Rain Garden facilities are shallow basins that utilize engineered soil media and vegetation to reduce contaminants through filtration and infiltration. Additionally, due to the detention time within these facilities, they provide peak management control for smaller storm events such as the two year, and possibly ten year storms. They also provide beautification of yards, attract and





provide habitat for pollinators and birds, and do not require mowing. This type of BMP is often used in green street applications, and are placed just upstream of existing drainage structures to intercept roadway runoff. Given the large presence of Institutional, commercial and industrial infrastructure within the Rocky Branch Watershed, these facilities are an attractive and potentially largely beneficial practice for Rocky Branch that should be strongly considered.

#### **7.1.1.1.3 Green Roofs**

Green Roofs have many water quality benefits such as filtration of pollutants from runoff and reducing total runoff and flooding potential. Vegetated green roofs can help mitigate this problem by retaining storm water, keeping an average 56% of annual rainfall from running off roofs and detaining the rest, slowing it's progression into the storm water system. Recent advances in green roof design include modular systems that allow for the retrofit of existing roofs and advancements in vegetation selection and irrigation to ensure survivability throughout the year.

Green roofs have other benefits as well such as reducing the urban heat island affect, filtering the air moving across them, and providing habitat for birds and insects.

Given the large presence of institutional, commercial and industrial infrastructure within the Rocky Branch Watershed, Green Roofs are an attractive and potentially largely beneficial practice for Rocky Branch that should be strongly considered.

#### **7.1.1.1.4 Green Streets**

Green Streets are roadways that are designed to reduce and filter stormwater runoff. The benefits of green streets are that they can be utilized in areas where there is not enough open space for larger traditional stormwater practices. Green streets use LID techniques such as bioretention BMPs, tree box filters, and pervious surfaces that are constructed within the street right of ways while utilizing existing drainage infrastructure. Green streets can be coupled with roadway maintenance or utility projects or act as stand-alone projects. The green street methodology can be applied to parking lots as well. Micro stormwater facilities can be installed in parking islands and along the perimeter of the lot. To acquire additional space for these facilities, parking lots may be restriped to reduce the required foot print, but allow for the same number of spaces by using diagonal parking with one way parking aisles.



#### **7.1.1.1.5 Boulevard Approach**

This approach entails the placement of street trees with an associated underground stormwater detention system that will store roadway runoff but also allow void space for the tree's roots to grow. This detention system would be placed under the sidewalk, with an inlet to allow

interception of runoff. The detention system would be comprised of a subsurface plastic support system, such as “Storm Tank Urban Root System” or an equivalent product. This system would support the weight of the surface and any loads applied to the surface, while providing void space filled with uncompacted soil. The soil would promote root growth and tree health. Additional units may be left unfilled along the outer perimeter to provide increased storage.

#### **7.1.1.1.6 Rain Harvesting (Cisterns)**

Over the last century, impervious surfaces like concrete, asphalt and roofing materials have been diverting natural rainwater absorption from developed areas and begun depletion of the local underground aquifers. By capturing as much rainfall as possible from buildings and structures, that water may be used to irrigate landscaping, wash vehicles, or other non-potable water uses such as high volume alternating current (HVAC) cooling water. Cisterns may be large underground tanks sized to collect and store roof discharge from multiple buildings, or small stand-alone barrels intended to collect runoff from residential roofs. Cisterns are well suited to academic institutions or municipal properties as guidelines may be easily enforced on the operation and maintenance of these systems. The areas of these impervious surfaces collected can be used to estimate potential pollutant load reductions as a result of cistern installation.

#### **7.1.1.2 Stormwater Management Facilities**

Due to the urban nature of Rocky Branch’s watershed, opportunities for traditional structural stormwater management facilities are limited. Traditional stormwater management facilities include underground stormwater detention facilities, detention/retention ponds, above and below ground sand filters. The underground facilities are well suited for parking lots or athletic fields as they do not impact the usable space. There are a multitude of proprietary underground storage systems that provide for easy construction. Above ground sand filters could be placed along parking lot perimeters. Large detention basins can be multi-use facilities that during dry periods serve as an athletic field or open space, while providing storage during rain events.



#### **7.1.1.3 Stream Restoration**

Stream restoration practices are used to enhance the aquatic function, appearance, and stability of stream corridors. Stream restoration practices can range from routine, simple stream repairs such as vegetative bank stabilization and localized grade control to comprehensive repairs such as full channel redesign and realignment. Stream cruising efforts performed in the Rocky Branch watershed identified restoration opportunities for stream repair and buffer reforestation. Lengths of eroded and altered channel segments were recorded during the stream cruising effort.



Stabilizing the stream channel improves water quality by preventing soil and the pollutants contained in it, from eroding into the stream and receiving waters.

#### **7.1.1.4 Reforestation/Buffer Establishment**

Trees provide air and water quality benefits, as well as aesthetic value. They provide habitat for terrestrial and aquatic wildlife and shade that helps keep water temperatures low. Trees also help slow runoff and absorb nutrients through their root systems. Converting open pervious areas into forested areas through tree planting can reduce pollutant loads to nearby water bodies and also reduce erosion. Consideration should also be made to the potential relocation of aerial utility lines to increase tree coverage along street frontage and other areas where shading and infiltration would be beneficial. The City of Columbia manages a tree planting program that has been installing 500-800 trees per year.

Trees improve water quality by capturing and removing pollutants in runoff including excess nutrients through their roots before the pollutants enter groundwater and streams. Tree leaves and stems also intercept precipitation, reducing the energy of raindrops and preventing excess erosion from their impact on the ground. In addition to water quality improvement, trees provide air quality, aesthetic, and economic benefits. For example, trees strategically planted around buildings can form windbreaks to reduce heating costs in the winter and can provide shade, reducing cooling costs in the summer.

Stream riparian buffers are critical to maintaining healthy streams and rivers. Forested buffer areas along streams improve water quality and prevent flooding by filtering pollutants, reducing surface runoff, stabilizing stream banks, trapping sediment, and providing habitat for various types of terrestrial and aquatic life. Buffer encroachment as a result of development was consistently noted during uplands and stream surveys conducted throughout the watershed. Approximately 42,000 linear feet of inadequate buffer was identified during the stream cruising effort. Channel encroachments limit available space for riparian buffer establishment.

#### **7.1.1.5 Infrastructure Improvement**

As discussed in the Hydrology and Hydraulic section (**Section 4.3**) above, replacement of undersized culverts, stabilization of outfalls, and removal of channel obstructions would improve conveyance of storm events and reduce flooding. Building on current analysis and recommendations from previous studies, the proposed improvements focus primarily on new cross-section recommendations at crossings that play a large role in controlling water surface profiles.

For several culvert locations, providing a beveled culvert top edge will improve conveyance. The bevel is proportioned based on the culvert barrel or face dimension and operates by decreasing the flow contraction at the inlet. Adding bevels to a conventional culvert design with a square-edged inlet increases culvert capacity by 5 to 20 percent. The higher increase results from comparing a bevel-edged inlet with a square-edged inlet at high headwaters. The lower increase is the result of comparing inlets with bevels with structures having wingwalls of 30 to 45 degrees.

Numerous storm drain outfalls are located along Rocky Branch, and many are in disrepair. Outfall retrofits consist of various methods used to reduce velocity and energy and the potential for scour. Modifications include lowering the outfall to the current stream bed elevation, constructing energy dissipation stilling basins, providing riprap outfall protection, and repairing



failed end walls. Repairing outfalls will reduce the sediment load within the channel during rain events by reducing the velocity and energy of these outfalls, thus improving the water quality within Rocky Branch.

Exposed utilities along Rocky Branch and its tributaries should be addressed. These utilities risk rupture or damage due to debris conveyed by storm events, as well as disrupt flow creating erosion and in stream obstructions. Modifications to either the channel or utility should be evaluated.

### 7.1.2 Enhanced Stormwater Management Requirements

While the Rocky Branch Watershed is considered a Vital Water Resource which enacts more stringent stormwater management criteria, additional steps are recommended to improve water quality and reduce peak discharges within the watershed. Since this watershed is comprised of many smaller urban parcels, development activities will often result in less than one acre of disturbance, allowing the development to be exempt from the more restrictive vital water resource criteria. Reducing the one acre minimum disturbance requirement to 0.20 acres would mandate greater implementation of low impact design, while allowing smaller residential redevelopment to occur on individual lots without placing undue financial burden on homeowners. Additional, elimination of the ability to acquire waivers or variances in special protection watersheds would help enforce the current regulations for the area. If for some reason, a development project could not meet the stormwater regulations, a fee in lieu program should be developed. Fees generated by this program would be used to provide regional stormwater retrofit activities such a stream restoration, green streets, or property acquisition within the stream buffer areas. Many urban cities have intensive fee in lieu programs that not only account for an initial fee, but a reoccurring fee placed on the property for utilizing the fee in lieu program.

In addition of enhanced stormwater management regulations, the City should enforce current regulations to the fullest. Section 21-46 of the Columbia, SC Code of Ordinances indicates:

*“Every person owning property through which a watercourse passes, or such person's lessee(s), shall keep and maintain that part of the watercourse within the property free of trash, debris, excessive vegetation (other than that which is required by water quality buffers), and other obstacles that would pollute, contaminate, or significantly retard the flow of water through the watercourse. In addition, the owner(s) or lessee(s) shall maintain existing privately owned structures within or directly adjacent to a watercourse, so that such structures will not become a hazard to the use, function or physical integrity of the watercourse.”*

Rocky Branch, for the majority, is encapsulated by privately or university owned land. In many of these instances, the stream has been neglected and not properly maintained as directed in the City Ordinance. Enforcement of this regulation, with proper public education, would have a minimal expense for the City while improving the conveyance within the channel.

Many jurisdictions faced with flooding and water quality issues are turning to volume reduction methodology in lieu of traditional peak management approaches (detention/retention). Volume reduction consists of capturing runoff and infiltrating it onsite while not allowing it to be discharged offsite effectively maintaining the sites predevelopment hydrology such as woods in



good condition. An alternative to volume reduction, for areas that lack infiltration due to high ground water or poor soils, treatment of runoff up to 2.6 inches have been implemented. This approach is equivalent to storing and providing water quality treatment of the 1-year storm runoff volume.

### 7.1.3 Stormwater Education and Outreach

Education and outreach tools can be used to inform residents of the water quality impacts associated with large impervious parking lots, driveways, or patios and options available for conversion to or incorporating more permeable surfaces. We know that Sustainable Midlands, Rocky Branch Alliance and other watershed groups have very active outreach programs in the Columbia area already. The City has programs such as Blue Thumb Landscaper and My River Starts Here which serve to raise awareness of watershed health and the importance of the individual resident's role in watershed health. Continuing to develop existing and similar programs is recommended.

**Figure 7.1 Example City of Columbia Educational Program: My River Starts Here**



### 7.1.4 Tree Planting Incentives Programs

Tree planting incentive programs to convert private open areas in the upland portions of the watershed can help increase the success of planting efforts. Converting open pervious areas into forested areas through tree planting can reduce pollutant loads to nearby water bodies and also reduce erosion. Canvassing residents and/or contacting homeowner associations can be effective techniques for implementing an open space tree planting program within a neighborhood. Initiatives such as the 10,000 Tree Program co-sponsored by the City of Columbia and Columbia Green are recommended.

## 7.2 Citizen-Based Strategies

The participation of citizens in watershed restoration is an essential part of the integrated watershed plan process. When large numbers of individuals become involved in citizen-based water quality improvement initiatives, changes can be made to the aesthetic and chemical aspects of waterways within a watershed that would not be possible otherwise. Citizen participation and stewardship is critical to the implementation and long-term maintenance of restoration activities. Key citizen-based strategies proposed for Rocky Branch are discussed in the following sections.



### 7.2.1 Downspout Disconnection

Disconnected downspouts that direct rooftop runoff to pervious surfaces can help reduce runoff and pollutants introduced to local streams. This can be achieved through downspout redirection (from impervious to pervious areas, i.e. driveways to lawns), rain barrels, and/or rain gardens. A combination of outreach and awareness techniques and financial incentives can be used to implement a downspout disconnection program in neighborhoods identified as potential candidates.

### 7.2.2 Residential Nutrient Management and Lawn Maintenance

Raising awareness among citizens about some of the common activities around their homes and how those activities can negatively affect water quality is a vital, citizen-based strategy. Yards and lawns represent a significant portion of the pervious cover in a subwatershed and act as a major source of polluted runoff. Maintenance behaviors tend to be similar within individual neighborhoods and certain activities can impact subwatershed quality such as fertilization, pesticide use, watering, landscaping, and trash/yard waste disposal. Residential nutrient management efforts related to lawn can help reduce polluted runoff to nearby streams.

A well-maintained lawn can be beneficial to the watershed. However, lawn maintenance activities often involve over-fertilization, poor pest-management, and over watering resulting in polluted stormwater runoff to local streams. Lawns with a dense, uniform grass cover or signs designating poisonous lawn care indicate high lawn maintenance activities. Neighborhoods identified as having high lawn maintenance practices should be targeted for awareness programs emphasizing responsible fertilizing techniques such as proper application amount, proper time of year for fertilization, soil testing for nutrient requirements, and keeping fertilizers away from impervious surfaces. Lawn maintenance education can be achieved through door-to-door canvassing, informational brochures/mailings, excerpts in community newsletters, or demonstrations at community meetings. Information on organic alternatives to chemical lawn treatments should also be included in these outreach efforts.

## 7.3 Evaluation of Restoration Opportunities

Widespread factors such as high percent impervious cover, minimal quantity and quality controls for stormwater, length of enclosed pipe sections and associated erosive outfalls and poor instream and riparian habitat characterize the Rocky Branch Watershed as requiring immediate and expansive application of restoration and management activities. Essentially, all strategies for watershed management and project implementation presented herein should be applied watershed wide and in an aggressive manner.

Recommended locations and prioritization for restoration projects was based on a combination of the results of the hydrologic and hydraulic modeling (SWMM) and detailed field reconnaissance and data collection. The SWMM modeling has identified specific subwatersheds and locations within each where stormwater flow is most problematic; where flooding is prevalent creating “pinch points” of highly impacted areas. Addressing these pinch point areas and the contributing drainage is clearly a necessary priority presented herein. Improvement recommendations in these areas could include everything from a major structural fix to widespread implementation of neighborhood BMP’s.

Priority projects will also be extracted from the stream cruising data collected from the field reconnaissance and recommended where a) a particular problem is numerous and extensive



within a particular area or subwatershed and b) the severity of a problem identified is so severe to warrant restorative action. It should be noted that although pinch point flooding areas and their contributing watershed area will be the focus, additional projects will be recommended even though they are not associated directly with a flooding problem.

In addition to flooding pinch points, areas with multiple / chronic issues and highly severe sites, prioritization projects also have been selected within public and institutionalized properties. These include City, County, State and University properties. The large footprint of these properties within the Rocky Branch Watershed and the relative ease and feasibility of implementing a restorative project on public versus on private properties raises the priority.



## 8.0 Watershed Project Identification and Prioritization

Through integration of the in-field assessment efforts, SWMM modeling results, and watershed goals established by the stakeholders, 73 Watershed Projects have been identified within the Rocky Branch Watershed (**Figure 8.1**). **Table 8.1** (Individual Project Identification and Description) summarizes the results of the subwatershed prioritization and associated project identification. The prioritization ranking for the subwatersheds is directly related to the results of the hydraulic modeling which revealed the subwatersheds of Gregg Street and USC were most in need of rehabilitation. Within each subwatershed, projects were evaluated on acres of impervious treated, available open space, property ownership, potential conflicts, ease of construction, and cost.

Projects in **Table 8.1** have been grouped into five primary categories: LID or Low Impact Development which includes Green Roofs, Green Streets, and various BMP's to increase infiltration and reduce runoff; Stream Restoration including bank stabilization; Infrastructure Improvements which primarily denotes a recommendation for the replacement of a large drainage structure or modifications to an existing culvert to improve efficiency; Reforestation/Buffer Enhancement such as tree plantings in open spaces; and Stormwater Management which includes both recommendations to retrofit existing systems and proposals for additional detention projects.

Since Rocky Branch Watershed is an urban, heavily developed watershed, it is hard to find singular locations in each subwatershed to install a stormwater facility of a size adequate enough to result in an improvement to the watershed. Because of this a wide reaching network of stormwater facilities will be needed. A desktop analysis was performed on each subwatershed to identify areas that appear to have the available open space for a stormwater facility. Larger scale projects such as implementation of green streets and the boulevard approach should be included in future planning studies and large scale capital improvement projects such as major roadway rehabilitation. While these approaches have the ability to treat a large impervious area, because of their associated costs and level of planning involved they have been ranked lower than more affordable individual sites with fewer constraints to schedule and constructability. **Table 8.1** provides descriptions of project type, approximate size, location, proposed action, potential benefits, known constraints and estimated cost.

It should be highlighted that subwatershed ranking correlates to the degree of imperviousness and the modeled and observed impairment. At 49% impervious within the Rocky Branch Watershed, the Impervious Cover Model (Schueler, 2005) predicts stream quality that is non-supporting. As such, much of the focus for watershed improvements is recommended in upland and upper watershed areas targeting detention and infiltration to combat the level of imperviousness. That said, projects such as stream restoration, although low on the priority list, are still recommended as a means to both educate the public and connect them to the resource. Once the foundation of education and awareness of the local environment is established, it is much easier to identify, fund and implement needed restoration projects.

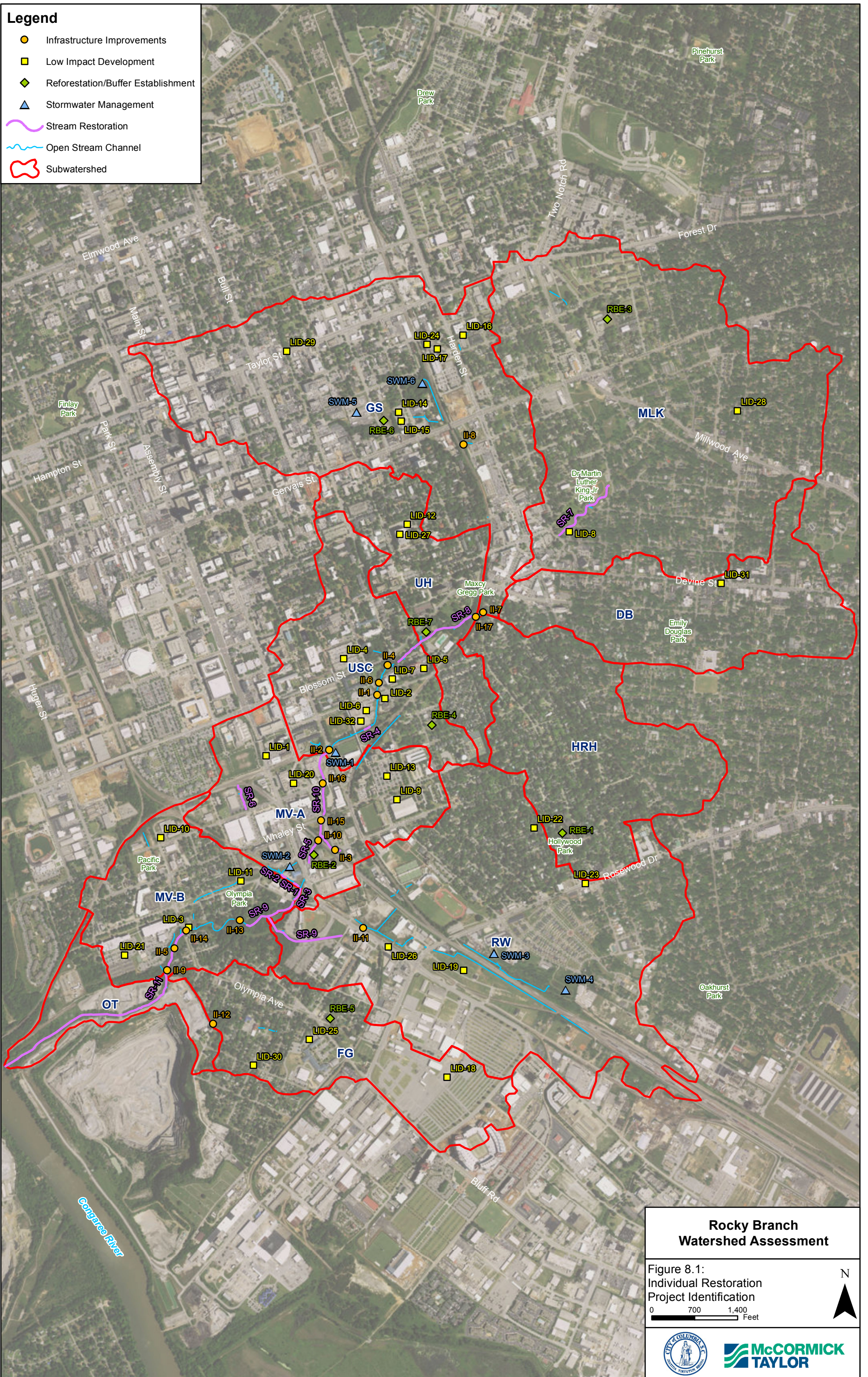
Proposed restoration treatments were selected based on the goals of the projects, constraints, feasibility and results of detailed site assessments. **Appendix D** provides a selection of available details for the primary restoration categories. In addition, potential design solutions in select areas were developed and illustrated with typical sections and details as appropriate.



While subwatersheds are ranked in priority order based on the degree of imperviousness, prioritization of projects is based on the category/type of project (see **Table 8.1**). To the extent that the City is capable, the City will generally consider the listed projects in presented order. However, it should be noted that many of the projects are on properties other than those owned and/or operated by the City. Due to this factor, as well as others (i.e. accessibility, feasibility, design constraints, etc.), the City may consider projects for implementation in an order other than that presented in **Table 8.1**.

**Legend**

- Infrastructure Improvements
- Low Impact Development
- ◆ Reforestation/Buffer Establishment
- ▲ Stormwater Management
- ~ Stream Restoration
- ~ Open Stream Channel
- Subwatershed



**Rocky Branch Watershed Assessment**

Figure 8.1:  
Individual Restoration  
Project Identification

0 700 1,400 Feet

N





**Table 8.1: Individual Project Identification and Description**

Stormwater Management		Infrastructure Improvements		Stream Restoration		LID		Reforestation/Buffer Establishment	
Project ID	Sub-watershed	Project Type	Location	Proposed Action	Benefits	Known Utilities and/or Constraints	Estimated Cost*	Additional Notes	
SWM-1	USC	Pond Retrofit	Sumter St Railroad Crossing and USC Dance Facility Building and Athletic Field	Expand footprint and convert to shallow marsh	Improve water quality and runoff reduction	Within 100-year floodplain	\$100,000		
SWM-2	MV-A	Pond Retrofit	Assembly St and Heyward St	Expand footprint and convert to shallow marsh or infiltration basin	Improve water quality and runoff reduction	Private Property	\$100,000		
SWM-3	RW	Pond Retrofit	Behind U-Haul Dealer by Superior St	Retrofit to prevent short-circuiting	Improve water quality and quantity control	Property Ownership	\$150,000		
SWM-4	RW	Pond Retrofit	Near Superior St and Mitchell St	Retrofit to prevent short-circuiting	Improve water quality and quantity control	Property Ownership	\$150,000		
SWM-5	GS	BMP Install	Property at Washington St and Gregg St	Retention Pond	Improve water quality and quantity control	Property Ownership	\$200,000		
SWM-6	GS	BMP Install	Barnwell Street Lot	Underground Quantity Storage With Infiltration or Bioretention	Improve water quality and quantity Control	Property Ownership	\$250,000		
II-1	USC	Culvert Modification	Rocky Branch at Wheat St	Recommend beveling culvert face at entrance	To reduce energy loss and associated flooding.	Overhead Utilities, Sanitary Sewer	\$20,000		
II-2	USC	Culvert Modification	Sumter St Crossing	Recommend beveling culvert face at entrance	Reduce flooding	Overhead Utilities, Sanitary Sewer	\$20,000	exposed pipes hanging on bridge	
II-3	MV-A	Outfall Enhancement	Channel between Railroad and Main St/Heyward St intersection	Stabilize Outfall and install energy dissipator	Reduce outfall channel erosion, protect sanitary line downstream	Sanitary Sewer	\$55,000		
II-4	USC	Sanitary Line Repair	Maxcy Gregg Park, West of Pickens St	Replace undercut sanitary line in bed	Protect sanitary line	Sanitary Sewer	\$75,000		
II-5	MV-B	Sanitary Line Repair	West of Olympia Ave	Replace sanitary line	Protect sanitary line	Overhead Utilities, sanitary sewer	\$100,000	Metal and plastic repairs evident, supports damaged	
II-6	USC	Outfall Stabilization	Southwest of Army ROTC, West bank of Rocky Branch Mainstem	Remove and replace endwall with drop structure	Stabilize outfall to protect infrastructure and reduce erosion		\$100,000		
II-7	GS	Outfall Repair	Eden's Property, Saluda Ave	Channel Stabilization	Reduce outfall channel erosion, protect adjacent infrastructure	Steep Stream Bank, sanitary sewer line and manhole	\$110,000	City looking at purchasing properties to restore area.	
II-8	GS	Outfall Repair	South of Gervais St, at Railroad and West of Harden St	Headwall replacement at Railroad crossing and stabilization of multiple outfalls.	Protect Railroad and adjacent infrastructure; reduce erosion.	Sanitary Lines	\$200,000	Costs here dependent on headwall requirements for railroad	
II-9	MV-B	Infrastructure Removal	Downstream Olympia Ave	Remove former railroad bridge	Reduce flooding	Overhead Utilities, sanitary sewer	\$300,000		
II-10	MV-A	Culvert Replacement	Railroad Crossing at Whaley St	Replace Culvert with adequately sized structure	Reduce flooding	Railroad	\$1,000,000	This is a CSX project	
II-11	RW	Culvert Replacement	Assembly St West of Rosewood St	Replace Culvert with adequately sized structure	Reduce flooding	Overhead Utilities, sanitary sewer	\$1,500,000	Repair bank erosion as well	
II-12	FG	Rerouting	Georgia St East of Vulcan Quarry	Large portion of this basin drains into the Vulcan Materials mine through a 60 inch RCP on Georgia Street, reroute this drainage down Delaware Street to Rocky Branch Mainstem	Reduce flooding	Overhead Utilities, sanitary sewer	\$1,500,000		
II-13	MV-B	Culvert Replacement	Old Railroad Berm	Dual 10' x 12' culverts recommended	Reduce flooding	Overhead Utilities, sanitary sewer	\$1,500,000	crossing through old railroad berm desirable location for greenway	



Project ID	Sub-watershed	Project Type	Location	Proposed Action	Benefits	Known Utilities and/or Constraints	Estimated Cost*	Additional Notes
II-14	MV-B	Culvert Replacement	Olympia Ave	Dual 10' x 10' culverts recommended	Reduce flooding	Overhead Utilities, sanitary sewer	\$1,500,000	This area is potential greenway crossing for Olympia to Congaree. May be desire by locals for trail under Olympia Road.
II-15	MV-A	Culvert Replacement	Whaley St and Main St	Dual 25' x 6' culverts recommended	Reduce flooding	Overhead Utilities, Sanitary Sewer	\$3,000,000	This is location of USGS gage
II-16	MV-A	Culvert Replacement	Catawba St and Main St	Dual 20' x 6' culverts recommended	Reduce flooding	Overhead Utilities, Sanitary Sewer	\$3,000,000	Possibility that USC may remove the existing structure and road crossing.
II-17	UH	Bridge Replacement	Northeastern End of Maxcy Gregg Park	Replace Railroad bridge with full span structure	Reduce flooding	Overhead utilities, Sanitary Sewer, private property	\$5,000,000	near the end of its service life and there is substantial scour upstream of the bridge
SR-1	MV-A	Bank Stabilization	Railroad Embankment Behind Church of Jesus Christ	Bank Stabilization (200 LF)	Stabilize bank to reduce erosion and protect infrastructure	Railroad, private property	\$150,000	This would be a CSX project
SR-2	MV-A	Bank Stabilization	Adjacent to Railroad Behind Church of Jesus Christ	Bank Stabilization (250 LF)	Stabilize bank to reduce erosion and protect infrastructure	Railroad, private property	\$150,000	Should be done in conjunction with BMP for parking lot.
SR-3	MV-B	Bank Stabilization	Rocky Branch Mainstem extending from Dreyfuss Rd north to Railroad	Bank Stabilization (250 LF)	Stabilize bank to reduce erosion and protect infrastructure	Sanitary Lines, private property, railroad	\$150,000	
SR-4	USC	Stream Restoration	Solomon Blatt Building	Bank Stabilization (100 LF)	Protect infrastructure and reduce erosion	Poor access, Railroad Embankment, Blatt Building	\$250,000	Opposite of Solomon Blatt Building
SR-5	MV-A	Bank Stabilization	Edge of Shopping Center Parking Lot East of Railroad and West of Assembly St	Bank Stabilization (600 LF)	Protect infrastructure, Reduce erosion; opportunity to incorporate vegetation closer to channel	Sanitary lines, adjacent infrastructure	\$300,000	
SR-6	MV-A	Stream Restoration	Tributary Between Catawba St and Railroad by Richland Industrial	Severely impacted reach requiring restoration	Improve stream stability, Reduce stream bank erosion, improve instream and riparian habitat and aesthetics	Railroad, multiple Sanitary Lines, adjacent infrastructure	\$350,000	Potential onsite wetlands
SR-7	MLK	Stream Restoration	MLK Park	Bank stabilization (800 LF)	Reduce stream bank erosion, improve public safety	Sanitary Sewer	\$350,000	This stream was restored previously, however, many bank sections are failing.
SR-8	UH/USC	Stream Restoration	Maxcy Gregg Park	Invasive Species Removal, Bank Stabilization, Floodplain Reconnection, Riparian Buffer Establishment (1250LF)	Improve stream stability, Reduce stream bank erosion, increase floodplain connection, improve instream and riparian habitat	Sanitary Sewer	\$500,000	Project extends within UH and USC subwatersheds
SR-9	MV-B/RW	Stream Restoration	Bluff Rd to Dreyfuss Rd	Debris removal and natural stabilization, Channel geometry modification	Improve floodplain connectivity and stream stability, Reduce stream bank erosion, improve instream and riparian habitat and aesthetics	Sanitary sewer	\$500,000	FG channel work (Kroger mitigation) should be included in this project. SR limits extend within MV-B (Rocky Mainstem) and RW (tributary)
SR-10	MV-A	Stream Restoration	Mainstem of Rocky Branch from Sumter St to Whaley St	Channel daylighting through USC campus	Opportunity to remove stream from closed system. Reduce flooding.	Private Property, Sanitary Line crossing and exposed manhole	\$1,500,000	This potential project was identified by USC as potential mitigation for the Kroger development. Also provides greenway connection opportunities.
SR-11	OT/MV-B	Stream Restoration	Rocky Branch Mainstem from Olympia Rd to the Congaree River	Channel section inside Vulcan Materials active mine. Mine closure anticipated 2030 and reach should be restored for entire length.	Improve stream stability, restore natural functions, improve instream and riparian habitat, reconnect system with upstream reaches.	Multiple Sanitary Lines, powerlines, adjacent infrastructure, railroad timbers, private property	\$4,000,000	Extends within OT and MV-B subwatersheds. Would occur following mine closure.
LID-1	MV-A	BMP Install	Assembly St at Entrance to California Dreaming	Bioswale or Bioretention	Improve water quality and runoff reduction	Possible underground utilities	\$50,000	



Project ID	Sub-watershed	Project Type	Location	Proposed Action	Benefits	Known Utilities and/or Constraints	Estimated Cost*	Additional Notes
LID-2	USC	BMP Install	Children's Center at USC - Wheat St	Bioretention Boxes	Improve water quality and runoff reduction	Possible underground utilities	\$50,000	
LID-3	MV-B	BMP Install	Olympia Park	Bioretention or Sand Filter	Improve water quality and runoff reduction	Overhead Utilities, sanitary sewer	\$60,000	
LID-4	USC	BMP Install	Parking Garage at Blossom St, Bull St and Devine St	Linear Bioretention	Improve water quality and runoff reduction	Possible underground utilities	\$75,000	
LID-5	USC	BMP Install	1600 Park Circle	Bioretention	Improve water quality and runoff reduction	Possible underground utilities	\$75,000	
LID-6	USC	BMP Install	Solomon Blatt Building Parking Lot	Bioretention or Sand Filter	Improve water quality and runoff reduction	Possible underground utilities	\$75,000	
LID-7	USC	BMP Install	ROTC Building and Parking Lot	Bioretention	Improve water quality and runoff reduction	Possible underground utilities	\$75,000	
LID-8	MLK	BMP Install	MLK Park	Bioretention or Sand Filter	Improve water quality and runoff reduction	Possible underground utilities	\$100,000	
LID-9	MV-A	BMP Install	USC Field House at Bull St and Whaley St	Bioretention or Sand Filter	Improve water quality and runoff reduction	Possible underground utilities	\$100,000	
LID-10	MV-B	BMP Install	Catawba St and Wayne St	Bioretention or Sand Filter	Improve water quality and runoff reduction	Overhead Utilities, sanitary sewer	\$100,000	
LID-11	MV-B	BMP Install	Median Area of Heyward St and Lincoln St	Bioretention or Sand Filter	Improve water quality and runoff reduction	Overhead Utilities, sanitary sewer	\$125,000	Area contains an intermittent stream
LID-12	UH	BMP Install	Close-Hipp - Pendleton St and Barnwell St	Bioretention or Sand Filter	Improve water quality and runoff reduction	Possible underground utilities	\$125,000	
LID-13	MV-A	BMP Install	USC Parking Lot at Bull St and Whaley St	Bioretention or Sand Filter	Improve water quality and runoff reduction	Possible underground utilities	\$150,000	
LID-14	GS	BMP Install	South Carolina Probation Services	Bioretention or Sand Filter	Improve water quality and runoff reduction		\$200,000	
LID-15	GS	Green Roof	South Carolina Probation Services	Recommend installation of green roof units	Reduce runoff from State building rooftops	Varying roof types, infrastructure	\$220,000	Assumes 11,000 SF green roof
LID-16	GS	BMP Install	Behind First Calvary Baptist Church on Harden St	Pocket Wetland, Wet Pond or Bioretention, Channel Stabilization	Improve water quality and runoff reduction	Property Ownership	\$250,000	
LID-17	GS	BMP Install	Richland County Government Buildings	Bioretention or Sand Filter	Improve water quality and runoff reduction	Possible underground utilities	\$250,000	
LID-18	FG	BMP Install	State Fairground Parking	Bioretention or Sand Filter	Improve water quality and runoff reduction	Possible underground utilities	\$300,000	Also applies to RW subwatershed
LID-19	RW	BMP Install	Overflow parking for USC stadium complex	Bioretention or Sand Filter	Improve water quality and runoff reduction	Possible underground utilities	\$300,000	
LID-20	MV-A	Green Roof	USC Building between Assembly St, Main St, and Catawba St	Recommend installation of green roof units	Reduce runoff from USC building rooftops	Varying roof types, infrastructure	\$300,000	Assumes 15,000 SF green roof
LID-21	MV-B	BMP Install	Granby Mills Student Housing	Bioretention or Sand Filter	Improve water quality and runoff reduction	Overhead Utilities, sanitary sewer	\$350,000	
LID-22	RW/HRH	Green Streets	Hollywood -Rose Hill Development	Apply green streets template to reduce runoff from neighborhood	Improve water quality and quantity control. Improve aesthetics	Possible underground utilities	\$390,000	capture 1" of runoff, \$190/LF of managed roadway, assumed 2,060 LF
LID-23	RW	Boulevard Approach	Rosewood Dr - Assembly St to South Pickens St	Tree Boxes with underground detention cells	Improve water quality and runoff reduction	Possible underground utilities	\$400,000	\$7,500 Per Box, spaced every 30 LF along 1,600 LF of City block



Project ID	Sub-watershed	Project Type	Location	Proposed Action	Benefits	Known Utilities and/or Constraints	Estimated Cost*	Additional Notes
LID-24	GS	Green Roof	Richland County Government Buildings	Recommend installation of green roof units	Reduce runoff from County building rooftops	Varying roof types, infrastructure	\$450,000	Assumes 22,500 SF green roof at \$20/SF
LID-25	FG	BMP Install	Olympia Learning Center	Bioretention or Sand Filter	Improve water quality and runoff reduction	Possible underground utilities, property ownership	\$450,000	
LID-26	RW	Boulevard Approach	Assembly St - Whaley St to Rosewood Dr	Tree Boxes with underground detention cells	Improve water quality and runoff reduction	Possible underground utilities	\$500,000	\$7,500 Per Box, spaced every 30 LF along 2,000 LF of City block
LID-27	UH	Green Roof	Close-Hipp Building	Recommend installation of green roof units	Reduce runoff from building rooftops	Varying roof types, infrastructure	\$560,000	Assumes 28,000 SF green roof at \$20/SF
LID-28	MLK	Green Streets	Melrose Heights, Old Shandon Neighborhoods	Apply green streets template to reduce runoff from neighborhood	Improve water quality and quantity control. Improve aesthetics	Possible underground utilities	\$620,000	capture 1" of runoff, \$190/LF of managed roadway, assumed 3,275 LF
LID-29	GS	Boulevard Approach	Taylor St - Sumter St to Gregg St	Tree Boxes with underground detention cells	Improve water quality and runoff reduction	Possible underground utilities	\$625,000	\$7,500 Per Box, spaced every 30 LF along 2,500 LF of City block
LID-30	FG	Green Streets	Olympia-Granby	Apply green streets template to reduce runoff from neighborhood	Improve water quality and quantity control. Improve aesthetics	Possible underground utilities	\$680,000	capture 1" of runoff, \$190/LF of managed roadway, assumed 3,590 LF
LID-31	DB	Green Streets	Devine Blossom Neighborhood	Apply green streets template to reduce runoff from neighborhood	Improve water quality and quantity control. Improve aesthetics	Possible underground utilities	\$720,000	capture 1" of runoff, \$190/LF of managed roadway, assumed 3,802 LF
LID-32	USC	Green Roof	Solomon Blatt Building (USC)	Recommend installation of green roof units	Reduce runoff from USC building rooftops	Varying roof types, infrastructure	\$1,400,000	Assumes 70,000 SF green roof at \$20/SF
RBE-1	HRH	Tree Planting	Hollywood Park	Recommend tree plantings where feasible	Improve water retention and aesthetics.	Recreational use	\$4,000	0.2 acres assumed for cost
RBE-2	MV-A	Tree Planting	Assembly St at Railroad, Mainstem of Rocky Branch	Recommend tree plantings where feasible	Improve water retention and aesthetics.		\$10,000	Publicly owned
RBE-3	MLK	Tree Planting	St. Anna's Park and Anna Mae Dickson Mini Park	Recommend tree plantings where feasible	Improve water retention and aesthetics.	Recreational use	\$20,000	
RBE-4	USC	Tree Planting	NE of Intersection of Catawba St and Pickens St and Intersection of Rice St and Pickens St	Recommend tree plantings where feasible	Improve water retention and aesthetics.	Property Ownership	\$25,000	
RBE-5	FG	Tree Planting	East of Hasting Alley, North of Olympia	Recommend tree plantings where feasible	Improve water retention and aesthetics.		\$40,000	Public parcel
RBE-6	GS	Tree Planting	Richland County Probation Services	Recommend tree plantings where feasible	Improve water retention and aesthetics.		\$45,000	\$20,000 per acre
RBE-7	UH/USC	Tree Planting	Maxcy Gregg Park	Recommend tree plantings where feasible	Improve water retention and aesthetics.		\$80,000	Select open and bare spots, \$20,000 per acre

1. LID Estimated Costs assume maximized retrofit footprint. Opportunities exist to reduce scale to reduce cost and/or phase larger projects to budget costs incrementally.



To track progress in implementing stormwater restoration opportunities, the required water quality volume was determined for each subwatershed (**Table 8.2**). This volume was based upon the drainage area and the percent impervious cover. As facilities are constructed, the storage volume provided can be tallied and compared to the required volume that would treat the 1.0 inch or 1.2 inch runoff. As mentioned above, implementation of enough facilities to meet these goals is not practical due to right of way limitations. However, facilities that are feasible to construct can be oversized to provide additional storage towards the goal volume. Filtration facilities such as bioretention can have expanded temporary ponding areas or groundwater recharge reservoirs to store additional runoff. Wherever practical, runoff reduction methods should be utilized to not only provide water quality treatment but quantity management as well through infiltration. For non-structural practices such as pavement removal or tree planting and reforestation; credit can be calculated based upon the acreage of pavement removed. For tree planting, typically a composite of 100 trees per acre is needed to obtain stormwater credit. Because contiguous parcels of one acre or greater are difficult to locate in urban areas, an aggregate of smaller sites may be used. In regards to stream restoration, typically credit may be claimed for 1 acre of treated impervious for every 100 linear foot of restoration. Following this methodology will allow for milestones to be set and progress tracked.

**Table 8.2 Subwatershed Water Quality Volume**

Sub-watershed	Acres	Impervious Cover	Estimated Impervious Cover	Rv	Volume Required to Treat the 1" Runoff	Volume Required to Treat the 1.2" Runoff*
		%	Acres		ac-ft	ac-ft
GS	404	70%	283	0.68	22.9	27.5
USC	173	53%	92	0.53	7.6	9.1
MV-A	175	54%	95	0.54	7.8	9.4
UH	125	54%	68	0.54	5.6	6.7
MLK	503	47%	236	0.47	19.8	23.8
DB	192	47%	90	0.47	7.6	9.1
RW	489	41%	200	0.42	17.1	20.5
HRH	221	40%	88	0.41	7.6	9.1
FG	171	46%	79	0.46	6.6	7.9
MV-B	154	40%	62	0.41	5.3	6.3
OT	63	11%	7	0.15	0.8	0.9
Total	2,670		1,299		108.6	130.3

\* - Current "Vital Area" Regulation for New Development within Rocky Branch



## 9.0 Conclusions and Limitations

The Rocky Branch Watershed Assessment Report provides a detailed assessment of the existing conditions of the waterways and contributing watershed, hydrology and hydraulics analysis and recommends strategies and specific projects to reduce flooding and improve water quality. All streams within the watershed were cruised by foot and characterized for existing conditions of instream and riparian habitat, channel stability, presence and condition of drainage infrastructure, utilities and notation of unusual conditions. All data including site photographs are currently available via web link at <http://arcg.is/1SS8PYX>. In addition to its utility herein for evaluating the watershed needs and identifying projects, the stream cruising data will be a valuable inventory tool for the City of Columbia. The results of the stream cruising effort revealed nearly 10,000 linear feet of structurally altered channel, 42,000 linear feet of inadequate forest buffer and 3,000 linear feet of erosion.

The results of the hydrology and hydraulics analysis revealed high volumes of runoff from subwatersheds with imperviousness ranging from 40 to 70%, the latter in the Gregg Street subwatershed. Much of the infrastructure for drainage in the Rocky Branch Watershed is not able to accommodate a 2-year storm event, therefore flooding occurs frequently and at multiple pinch point locations. Recommendations to improve flooding conditions include no additions of imperviousness without full accommodations for retention, and the addition of areas throughout the watershed for detention, retention and infiltration

This Watershed Report provides a basic framework in three main areas to initiate the restoration of the Rocky Branch Watershed: Municipal and Institutional Strategies; Citizen Based Strategies; and the implementation of specific Watershed Projects identified. Municipal and Institutional Strategies include effective management and enhancement of Stormwater Regulations and retrofits of existing systems. Citizen based strategies include tree planting and down spout disconnection programs from Outreach Based initiatives. Locally, Sustainable Midlands and the Rocky Branch Alliance are very active and effective with public outreach.

The identification of Watershed Projects (**Table 8.1**) was developed based on the combined results of the stream cruising effort, the hydrology and hydraulics analysis and desktop analysis. The eleven subwatersheds were scored based on imperviousness, peak discharge and runoff per unit area. A total of 73 Watershed Projects were identified in the Rocky Branch Watershed. Projects identified are grouped into five primary categories:

- Stormwater Management which includes both recommendations to retrofit existing systems and proposal for additional detention projects.
- Infrastructure Improvements which primarily denotes a recommendation for the replacement or modification of a large drainage structures but also includes repair of outfalls and exposed utilities
- Stream Restoration including bank stabilization;
- LID or Low Impact Development which includes Green Roofs, Green Streets, and various BMP's to increase infiltration and detention;
- Reforestation/Riparian Buffer Enhancement such as tree plantings in open spaces and along stream corridors



Descriptions of project type, approximate size, location, proposed action, potential benefits, known constraints and estimated cost are provided in **Table 8.1**.

Property ownership and constructability (e.g. access, proximity to utilities, etc.), were considered in project selection and prioritization. Although Rocky Branch Watershed is highly impacted with many needs for restoration, there are many opportunities available based on the prevalence of public and institutional properties.

Large Infrastructure Improvement projects that are recommended include the replacement of a number of the undersized culverts in areas know to experience frequent flooding.

Stormwater Management facility recommendations include the retrofit of existing ponds either through additional grading for storage and/or reconfiguration of drainage structures to increase retention times. Recommendations for stormwater management also include the potential conversion of open channel segments within MLK and Maxcy Gregg Parks into retention basins.

Low Impact Development (LID) projects are of particular importance for the Rocky Branch Watershed as opportunities to retrofit impervious areas with BMP's to induce water detention filtration, and infiltration. Strong candidates for LID implementation include the USC bus lot at Barnwell Street and adjacent Richland County Probation Services property as well as multiple USC surface parking lots. An area often overlooked is runoff attributed from athletic fields. As these fields are reconstructed or repaired, consideration for stormwater management should be included such as underground detention or perimeter stormwater facilities.

Although relatively sparse in availability, undeveloped public areas were targeted for reforestation recommendations. These typically occur at parks and schools such as St. Anna's Park in the MLK subwatershed.

Stream restoration projects have also been identified and recommended. In general these projects did not score as high in priority which is attributed to both the greater need to control water volume and water quality and that the aquatic systems are non-supporting. Stream restoration projects in this watershed context are, however, an excellent means to educate and develop public awareness. There are many opportunities to connect the public and commerce with Rocky Branch through the continued development of Greenway corridors.

Estimated project and/or units costs are as follows:

- Stream restoration and outfall channel stabilization: \$400/LF
- Bioretention, Pocket ponds, berm and riser installation: \$42,000/imp acre treated
- Swales, grass channels, bioswales, baffle installation: \$36,000/imp acre treated
- Shallow wetland/marsh or new ponds: \$50,000/imp acre treated
- Green Roofs: \$20/SF
- Reforestation: \$20,000 per acre
- Boulevard : \$7,500 per tree box
- Pond retrofit: \$50,000 per acre

Construction costs for the stormwater management BMPs and outfall retrofits were based on similar recently constructed projects and institutional knowledge of green infrastructure costs. True costs of retrofits and restoration projects vary significantly with site conditions and may increase if additional effort is needed to prepare geotechnical reports, work around utilities



or perform additional grading based on field elevations. A design fee estimate of 30% for the construction cost was used for each of the above construction activities.



## References

AMEC Environment and Infrastructure Inc. 2012. Urban Study, Rocky Branch Watershed, Columbia, SC. Project Number 6250-12-007.

Barbour, M.T., J. Gerritsen, B.D. Snyder, and J.B. Stribling. 1999. Rapid Bioassessment Protocols for Use in Streams and Wadeable Rivers: Periphyton, Benthic Macroinvertebrates and Fish, Second Edition. EPA 841-B-99-002. U.S. Environmental Protection Agency; Office of Water; Washington, D.C.

Bettinger, J., J. Crane, and J. Bulak. 2006. Piedmont Stream Survey – Broad River Basin. South Carolina Department of Natural Resources. Columbia, SC.

City of Columbia. 2016. A Brief History of the City of Columbia. City of Columbia. Accessed 1/7/2016. <https://www.columbiasc.net/about-columbia>

Environmental Protection Agency. 2016. Storm Water Management Model. V. 5.1.010. Available online at: <https://www.epa.gov/water-research/storm-water-management-model-swmm>. Accessed 5/1/2016.

Federal Emergency Management Agency. 2010. Flood Insurance Study, Richland County, South Carolina, and Incorporated Areas. Washington, D.C. September 29, 2010.

Federal Emergency Management Agency. 2015. Preliminary Flood Insurance Study, Richland County, South Carolina, and Incorporated Areas. Washington, D.C. April 30, 2015.

Griffith, G.E., Omernik, J.M., Comstock, J.A., Schafale, M.P., McNab, W.H., Lenat, D.R., MacPherson, T.F., Glover, J.B., and Shelburne, V.B., 2002, Ecoregions of North Carolina and South Carolina, (color poster with map, descriptive text, summary tables, and photographs): Reston, Virginia, U.S. Geological Survey (map scale 1:1,500,000).

Liu, Dong. 2007. Summary Review of HEC-HMS Model and Updated Hydrologic Analysis of the Rocky Branch Drainage Basin in Conjunction with the Rocky Branch Hydraulic Analysis for the City of Columbia, SC. MA Engineering Consultants Inc. Project Number SD804801, Richland County.

Parsons Brinckerhoff (PB) Americas, Inc. 2007. Rocky Branch Watershed Study, City of Columbia 100% Report.

Schueler, T. R. 2005. An Integrated Framework to Restore Small Urban Watersheds. V. 2.0. Center for Watershed Protection. Ellicott City, MD.

South Carolina Department of Natural Resources. 2005. 2005 Comprehensive Wildlife Conservation Strategy. South Carolina Department of Natural Resources. Columbia, SC.



US Army Corps of Engineers Hydrologic Engineering Center. 2010. River Analysis System HEC-RAS. V.4.1.0 [Computer software]. Retrieved from <http://www.hec.usace.army.mil/software/hec-ras/downloads.aspx>

United States Department of Agriculture Soil Conservation Service. 1978. Soil Survey of Richland County, South Carolina. Natural Resource Conservation Service. Washington, D.C.

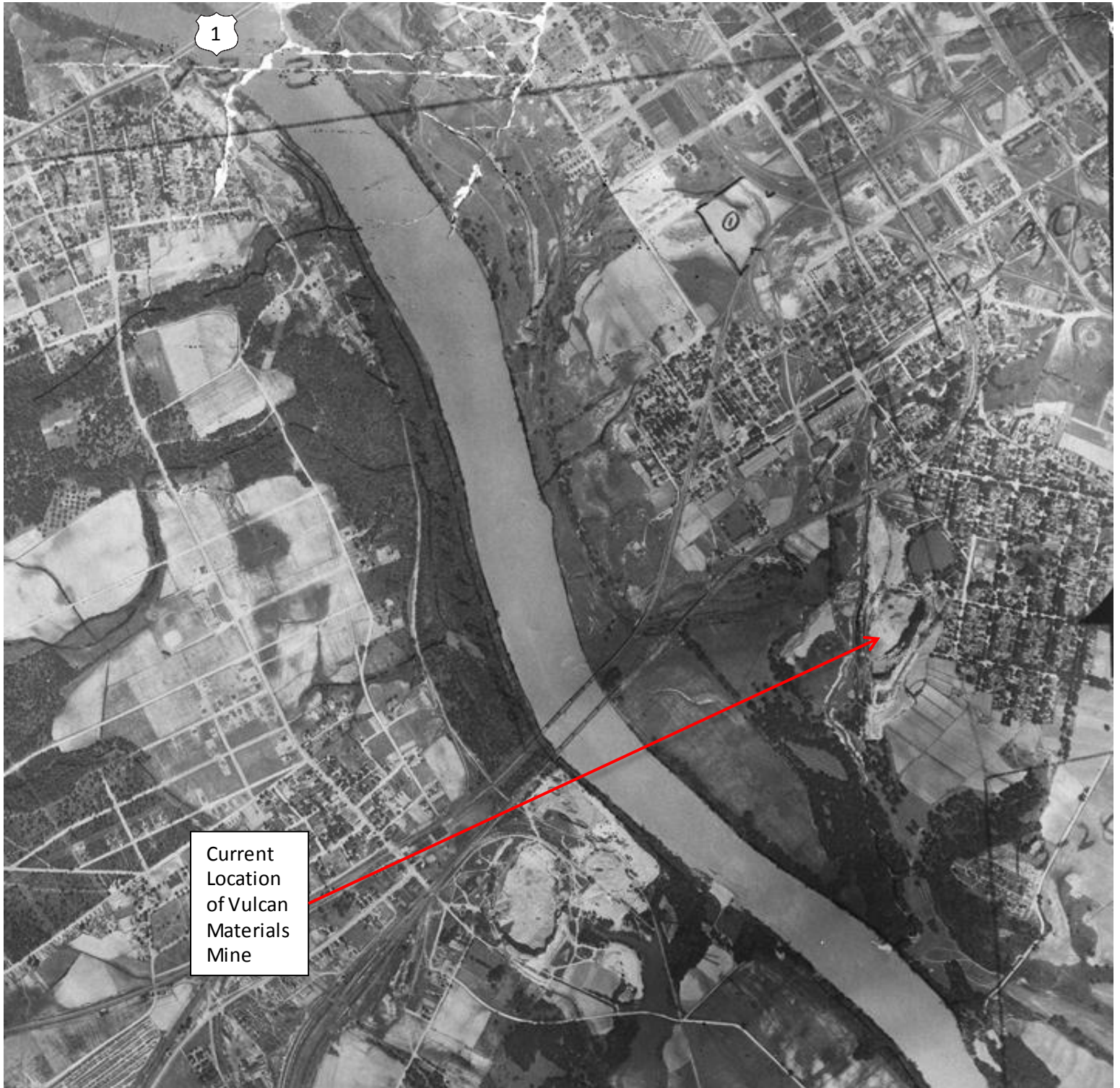
United States Department of Agriculture Natural Resource Conservation Service. 2016. Web Soil Survey. Natural Resource Conservation Service. Accessed 5/3/2016. <http://websoilsurvey.nrcs.usda.gov/app/>

Yetman, K.T. 2001. Stream Corridor Assessment Survey Protocols. Watershed Restoration Division, Maryland Department of Natural Resources. Annapolis, MD.

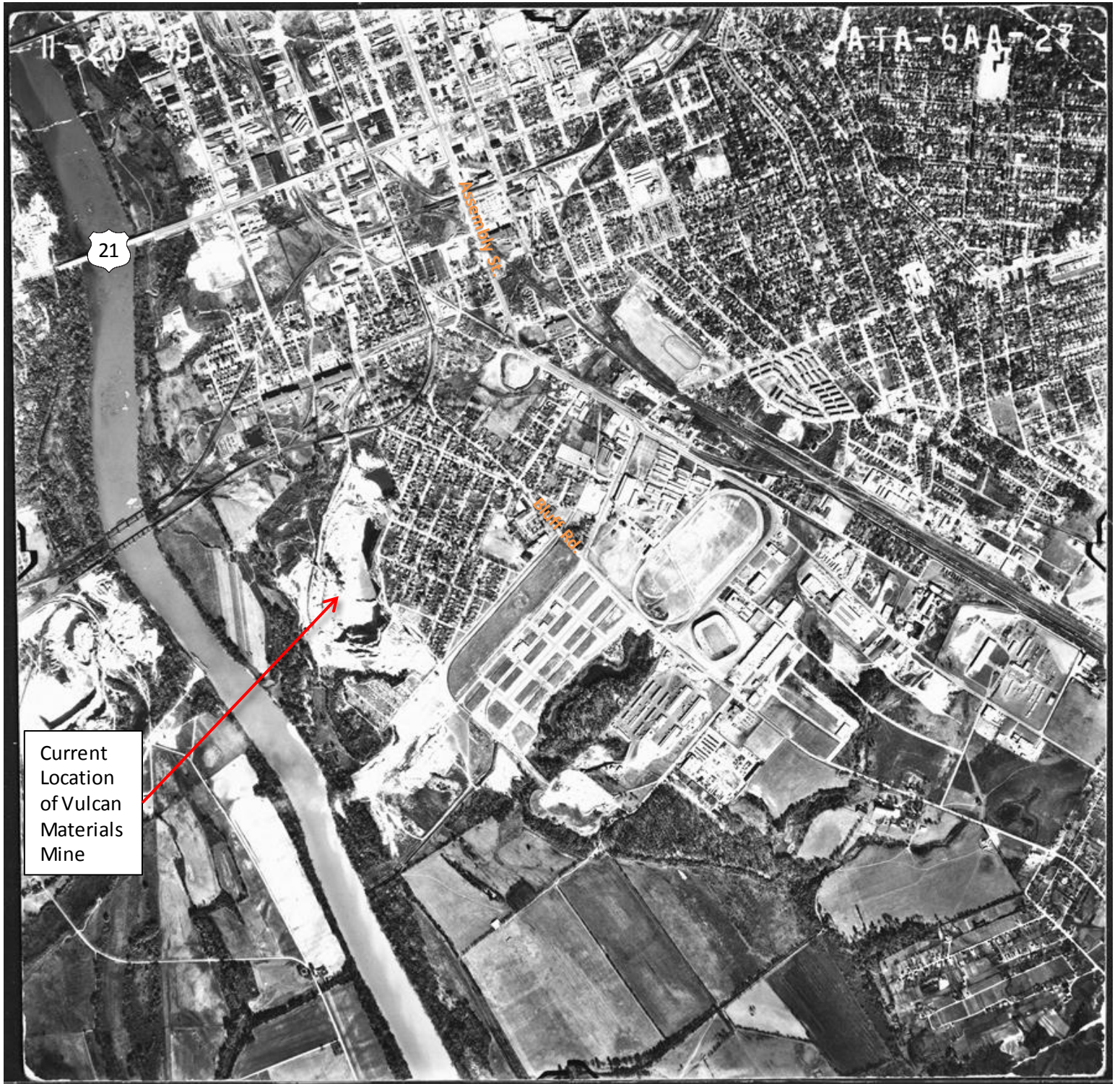
---

# Appendix A: Historic Aerial Photos

---



Rocky Branch Watershed 1938



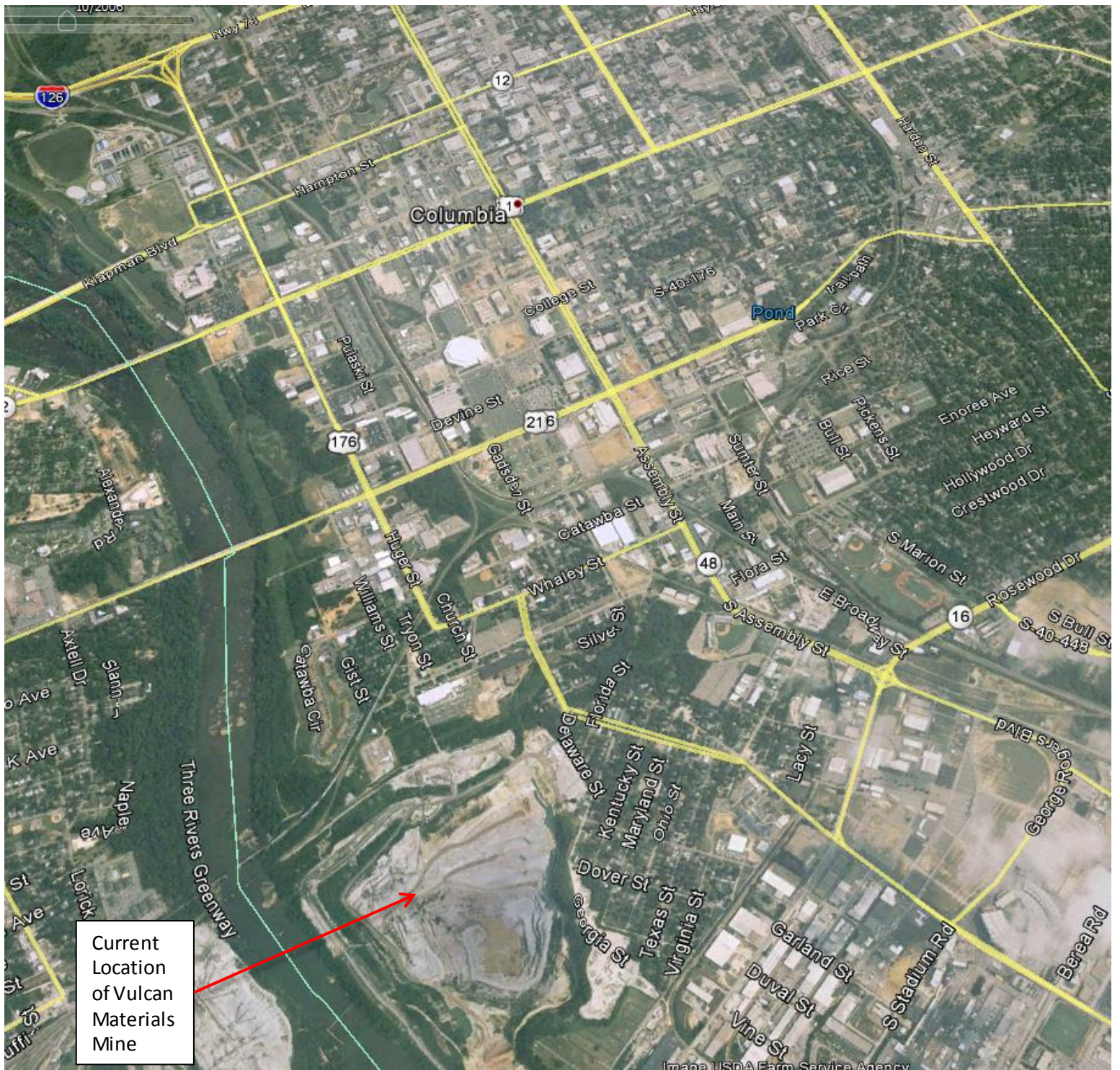
Rocky Branch Watershed 1959



Rocky Branch Watershed 1970



Rocky Branch Watershed 1995



Rocky Branch Watershed 2006



---

# Appendix B: Water Quality Data

---



## TECHNICAL MEMORANDUM

**TO:** McCormick Taylor, Inc.

**FROM:** KCI Technologies, Inc.

**DATE:** January 14, 2016

**SUBJECT:** Rocky Branch Watershed – Water Quality Analysis and Recommendations  
KCI Job Order No. 17159965.01

---

Rocky Branch is a small urban watershed located in Columbia, South Carolina. The watershed is approximately 3.8 miles<sup>2</sup> and drains primarily residential and commercial land uses. Rocky Branch is part of the Congaree River watershed. The Congaree River is listed on South Carolina's 303(d) List of Impaired Waters for *E. coli* bacteria, copper, mercury, pH, and turbidity. A Total Maximum Daily Load for *E. coli* is being developed. The impaired station on the Congaree River is a short distance upstream from the confluence with Rocky Branch. The City of Columbia has developed a TMDL Monitoring and Assessment Plan that describes the monitoring program for Rocky Branch. Water quality monitoring in Rocky Branch consists of two sites, Rocky Branch A (ROCA), located near Maxcy Gregg Park, and Rocky Branch B (ROCB), located at the Olympia Avenue crossing of Rocky Branch. A USGS stream gage (03050110) is located between the two sites. The water quality monitoring activities are managed by City of Columbia Stormwater Management.

### **Water Quality Analysis**

The following is KCI's analysis of available water quality data for Rocky Branch in the vicinity of the City of Columbia, South Carolina. The purpose of the analysis is to compile available water quality data to assess current water quality conditions in the watershed and to determine if the existing monitoring program should be modified to meet the data needs of the City of Columbia to inform management decisions related to water quality regulations and public health criteria.

### Site ROCA

*In situ* water quality data were collected from the ROCA site using a recording sonde set to collect data every 15 minutes. The sonde collected pH, specific conductance, water temperature, dissolved oxygen, and turbidity data. *In situ* water quality data were available for the period starting March 28<sup>th</sup>, 2014 through November 16<sup>th</sup>, 2015.

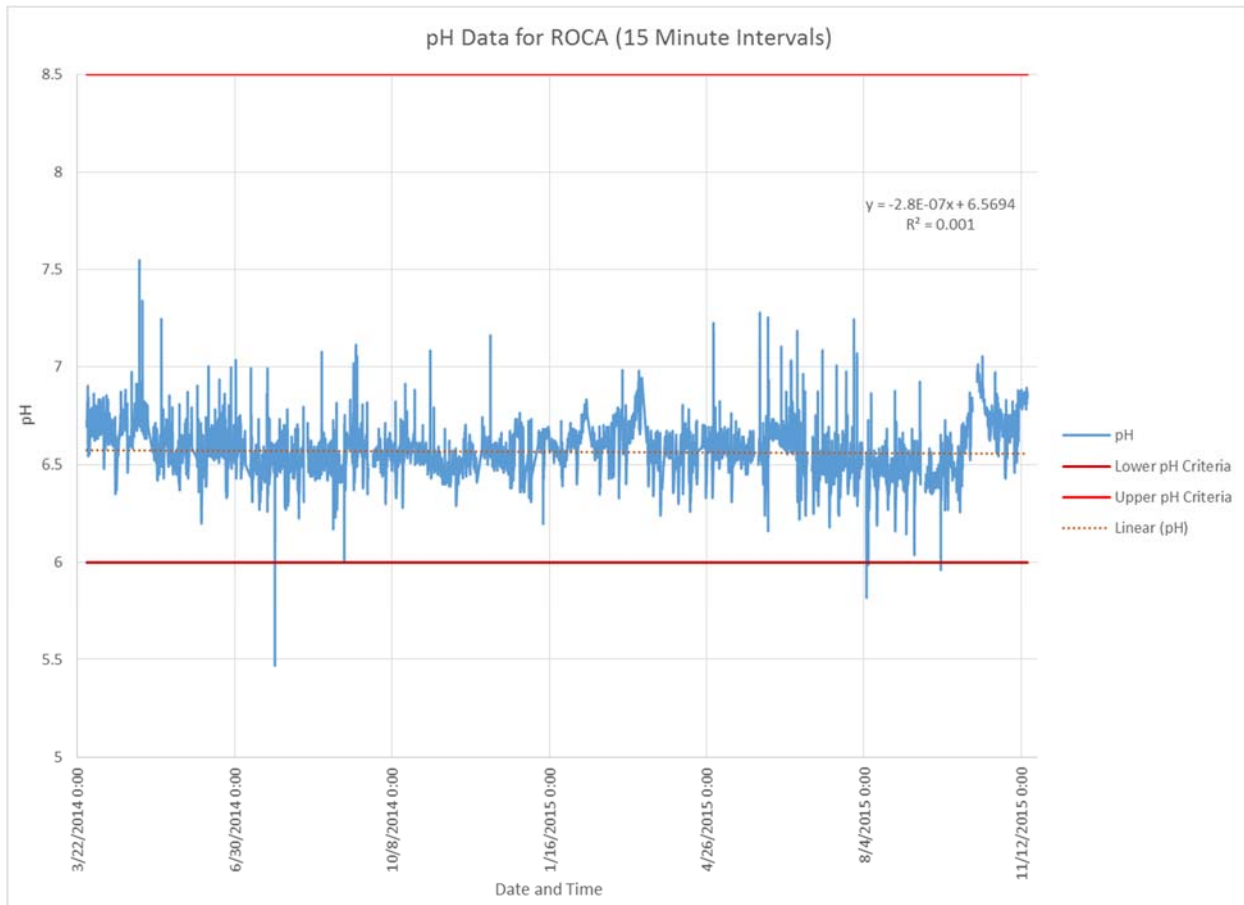
Water quality grab samples were collected 15 times during baseflow and stormflow between April 28<sup>th</sup>, 2014 and September 24<sup>th</sup>, 2015 at site ROCB. All water quality grab samples were analyzed for *E. coli* (MPN/100 mL), and 60% of samples were also analyzed for TSS (mg/L), total phosphorus (mg/L), and total nitrogen (mg/L).

### *pH Analysis*

Water quality sonde data collected at 15-minute intervals from site ROCA show that the water quality standard for pH of an acceptable range of 6.0 to 8.5 pH was violated 0.05% of the time (27 out of 52,923 records) over the period of record. All of the excursions outside of the water quality standards were below 6.0, none of the pH values were above 8.5.

A linear regression analysis was performed for 15-minute interval pH data from ROCA. The results of the linear regression analysis show a slight negative slope (-2.8209E-07), which was significant at the  $p < 0.01$  level ( $p < 0.001$ ). This indicates that the likelihood of this decreasing pH relationship occurring by chance is very small. The negative slope of the line indicates that pH values are decreasing very slightly throughout this dataset. This rate of change is so small that changes in observed pH values would happen over several tens of thousands of measurements. If this relationship holds true with data collected over additional time periods, it would take over a year for a realized 0.01 decrease in pH value.

	<i>Coefficients</i>	<i>Standard Error</i>	<i>t Stat</i>	<i>P-value</i>
Intercept	6.569434052	0.001158	5674.727	0
Slope	-2.82094E-07	3.79E-08	-7.44563	9.79453E-14



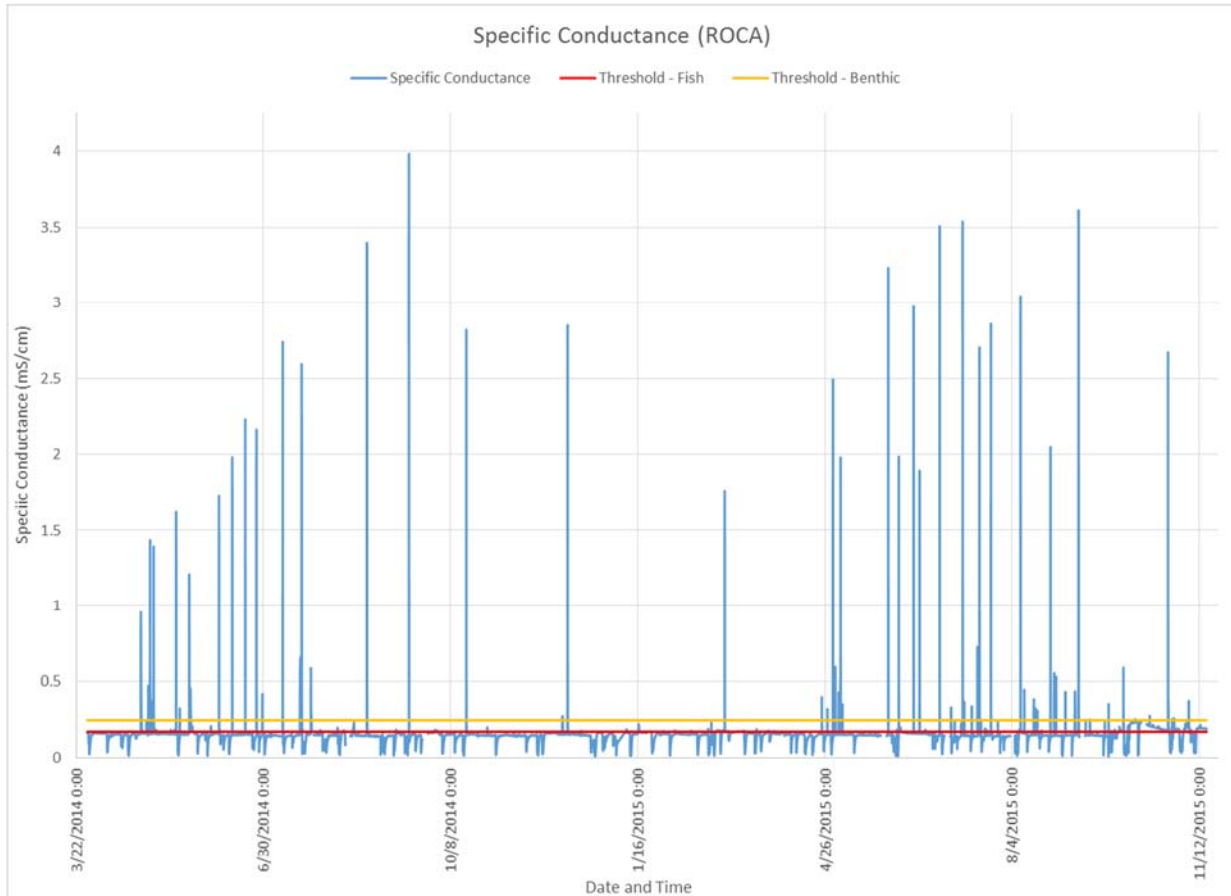
Monthly average pH and seasonal average pH were calculated for this site to investigate patterns and seasonality in the data. This created 21 monthly averages and seven seasonal averages. No patterns exist in monthly average nor seasonal average pH.

### *Specific Conductance*

South Carolina does not have water quality criteria for specific conductance, which is a measure of dissolved inorganic ions such as chloride, nitrate, sulfate and phosphate anions and sodium, magnesium, calcium, iron, and aluminum cations. Morgan et al., 2007, found biological assemblage impairment thresholds for biological impairment of 0.247 mS/cm for benthic macroinvertebrates and 0.171 mS/cm for fish in urban streams in Maryland. Rocky Branch is an urban stream so the impairment thresholds from Maryland data may be applicable. When compared against these values, the possible specific conductance impairment thresholds were exceeded in ROCA for benthic macroinvertebrate assemblage 1.26% of the time (666 records out of 52,819 total records), and for fish assemblage 12.84% of the time (6,780 records out of 52,819 total records).

Site ROCA had higher maximum observed specific conductance values than ROCB, but a much lower percentage of values above the possible biological assemblage impairment thresholds. At ROCA, almost

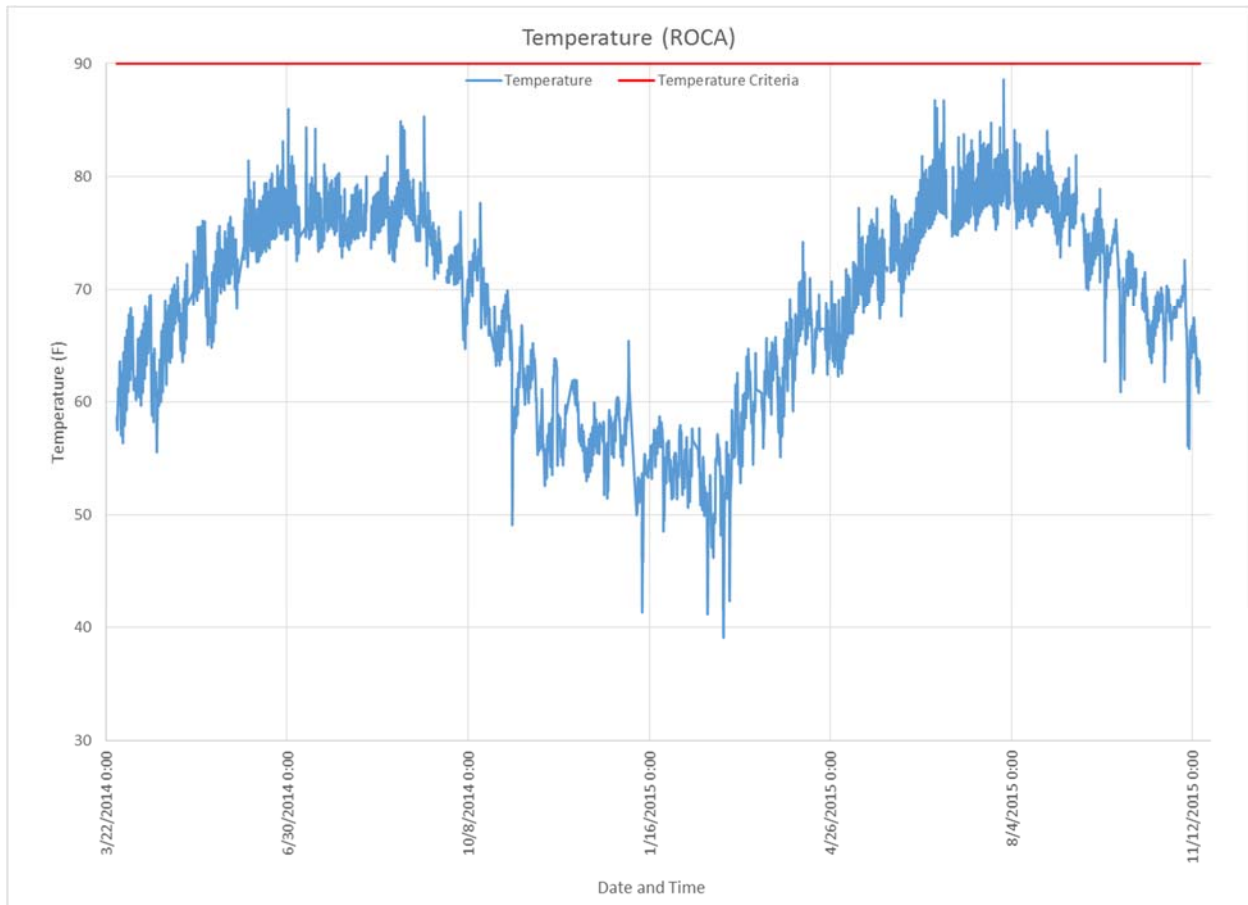
without exception, the highest specific conductivity events were observed with concomitant spikes in turbidity.



### *Water Temperature*

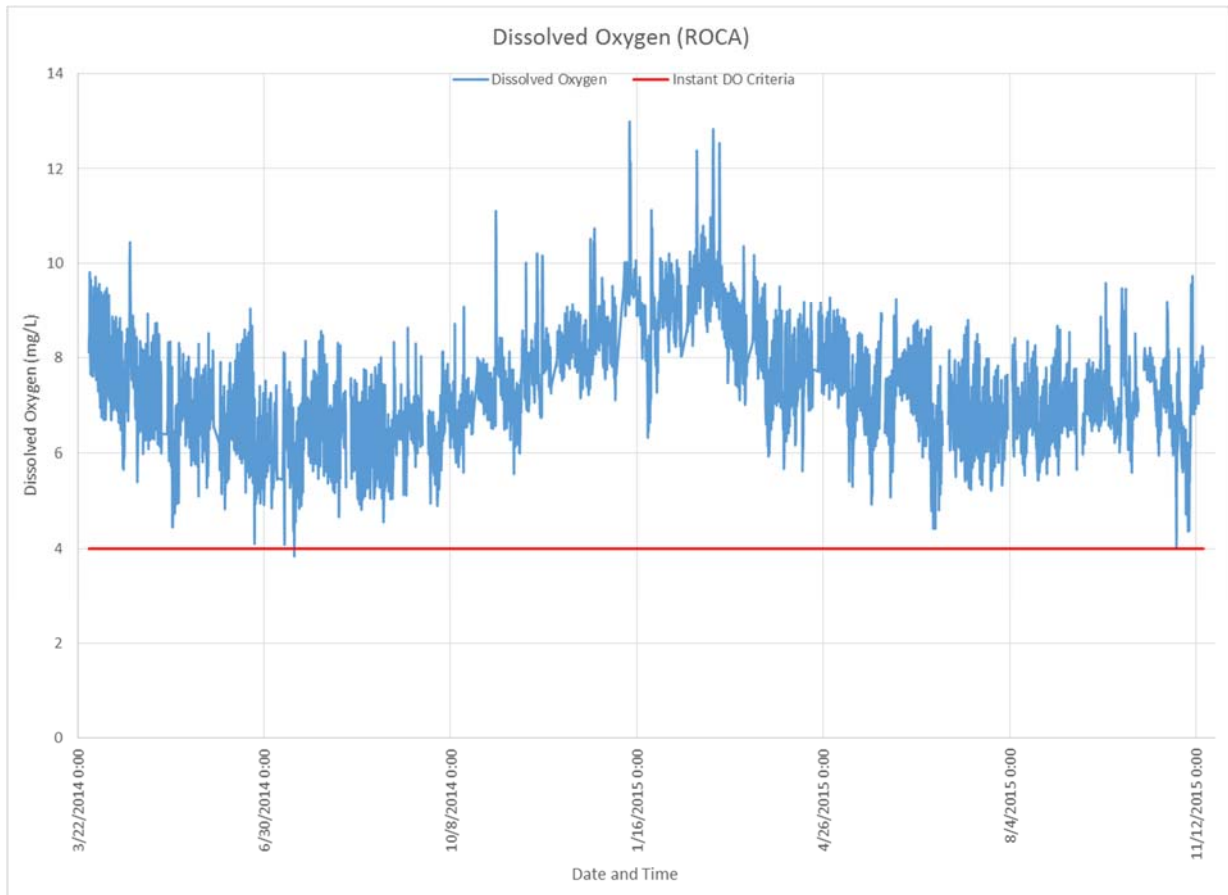
The water quality criteria for temperature of 90.0° F was not exceeded at ROCA. All temperature measurements were well below 90.0° F.

As expected, there is a seasonal and diurnal pattern to water temperature in Rocky Branch. The highest measured water temperatures occurred during the summer time. Summer is the time of the year with the highest air temperatures, and the greatest amount of solar radiation. These factors help warm water throughout the day. The highest temperatures measured each day were in the afternoon. Afternoon is usually the period of time with the highest air temperature, and sunlight has been warming the water and stream substrates throughout the day.



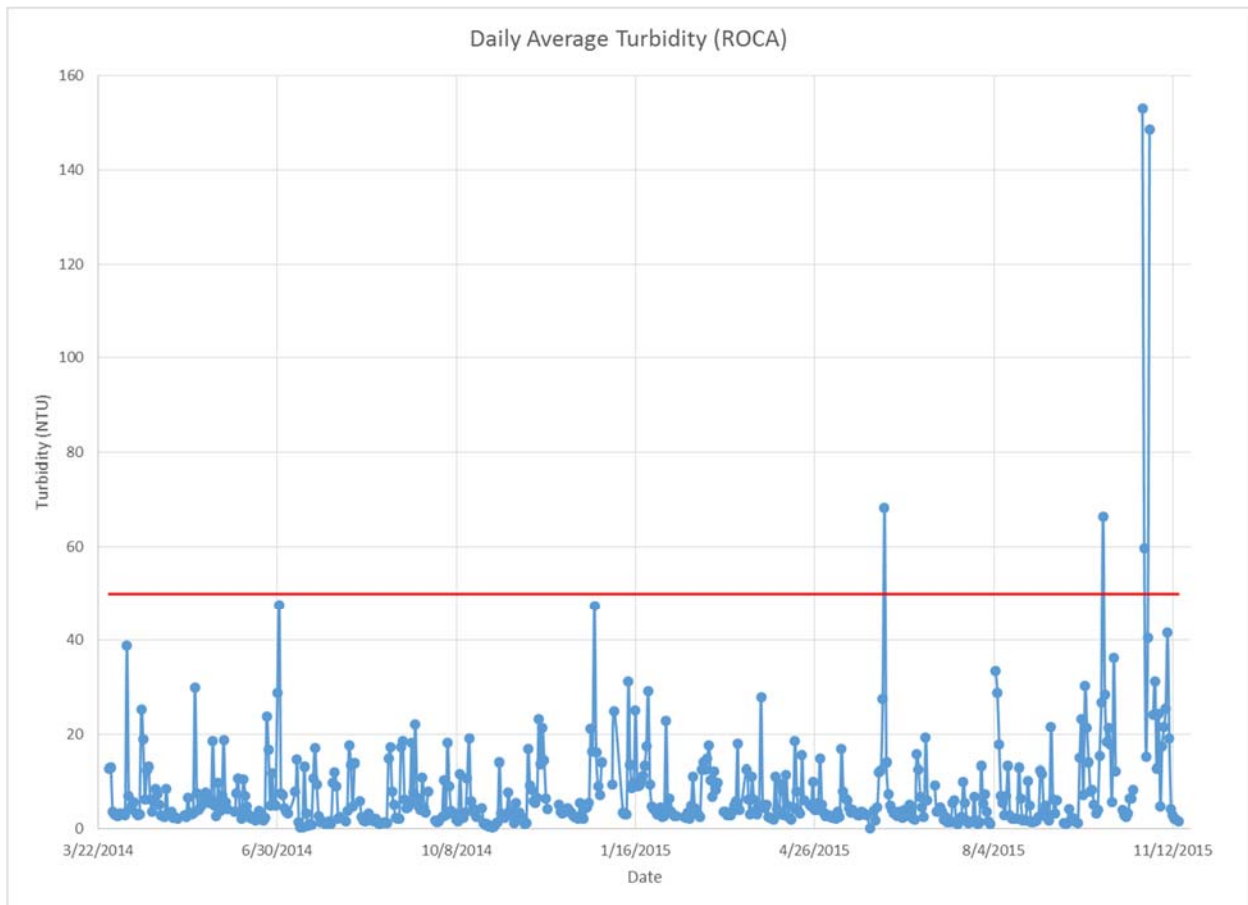
### *Dissolved Oxygen*

Water quality sonde data from site ROCA show that the instantaneous water quality standard for dissolved oxygen of 4.0 mg/L was violated 0.01% of the time (4 out of 52,929 records) over the period of record. Over the same period of time, the water quality standard for daily average dissolved oxygen of 5.0 mg/L was violated 0.00% of the time (0 out of 555 days). The instantaneous criteria violations happened over a 45-minute period on July 16<sup>th</sup>, 2014 from 05:15 to 06:00. July 16<sup>th</sup>, 2014 also had the lowest observed daily average dissolved oxygen concentration of 5.28 mg/L.



### *Turbidity*

Results of turbidity data from the water quality sonde at ROCA show that the turbidity water quality standard of 50.0 NTU was exceeded 1.27% of the time (644 records out of a total 50,609 records).



### *E. coli*

Water quality grab samples were collected at ROCA 15 times and analyzed for *E. coli*. These 15 samples were spread across 21 months, making statistical analysis of these data problematic. There are too few samples to perform a trend analysis. *E. coli* counts ranged from a high of 19,860 MPN/100mL to a low of 119 MPN/100mL. The mean was  $7,528.8 \pm 4,289.9$  with a standard deviation of 7,746.5.

South Carolina's water quality standard for fecal coliform is a geometric mean of 200 MPN/100mL of five samples collected over a 30-day period. There is no 30-day period throughout the period of record for ROCA where at least five samples were collected. A comparison of means is not possible. The water quality criteria allow for a percentage criteria, where recreational uses are supported if less than 10% of samples exceed 400 MPN/100mL. At ROCA 86.67% of samples exceed 400 MPN/100mL.

### *TSS*

Water quality grab samples were collected at ROCA and analyzed for TSS 9 out of 15 (60%) sampling events. These nine TSS samples were collected during four days: three samples on May 15<sup>th</sup>, 2014; four samples on November 17<sup>th</sup>, 2014; one sample on February 2<sup>nd</sup>, 2015; and one sample on September 24<sup>th</sup>, 2015. The TSS data are too infrequent to allow for any robust statistical analysis. TSS concentrations

ranged from a high of 120 mg/L to a low of 3 mg/L. The mean concentration was  $36.42 \pm 32.79$  with a standard deviation of 42.66.

#### *Total Phosphorus*

Water quality grab samples were collected at ROCA and analyzed for total phosphorus (TP) 9 out of 15 (60%) sampling events. These nine TP samples were collected during four days: three samples on May 15<sup>th</sup>, 2014; four samples on November 17<sup>th</sup>, 2014; one sample on February 2<sup>nd</sup>, 2015; and one sample on September 24<sup>th</sup>, 2015. The TP data are too infrequent to allow for any robust statistical analysis. TP concentrations ranged from a high of 0.44 mg/L to a low of 0.042 mg/L. The mean concentration was  $0.203 \pm 0.092$  with a standard deviation of 0.119.

#### *Total Nitrogen*

Water quality grab samples were collected at ROCA and analyzed for total nitrogen (TN) 9 out of 15 (60%) sampling events. These nine TN samples were collected during four days: three samples on May 15<sup>th</sup>, 2014; four samples on November 17<sup>th</sup>, 2014; one sample on February 2<sup>nd</sup>, 2015; and one sample on September 24<sup>th</sup>, 2015. The TN data are too infrequent to allow for any robust statistical analysis. TN concentrations ranged from a high of 3.82 mg/L to a low of 0.67 mg/L. The mean concentration was  $1.64 \pm 0.78$  with a standard deviation of 1.02.

#### *Site ROCB*

*In situ* water quality data were collected from the ROCB site using a recording sonde set to collect data every 15 minutes. The sonde collected pH, specific conductance, water temperature, dissolved oxygen, and turbidity data. *In situ* water quality data were available for the period starting March 27<sup>th</sup>, 2014 through November 16<sup>th</sup>, 2015.

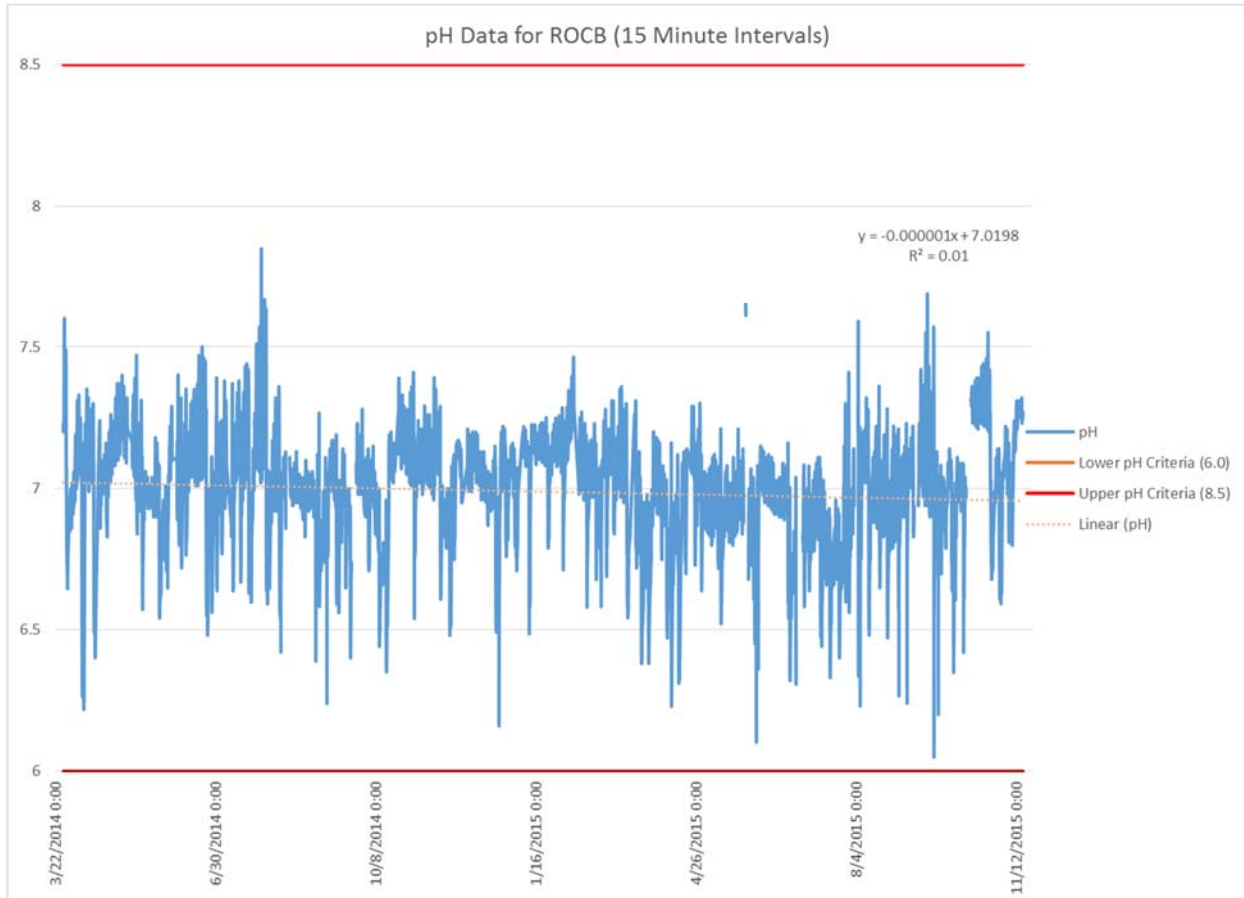
Water quality grab samples were collected 16 times between April 28<sup>th</sup>, 2014 and September 24<sup>th</sup>, 2015 at site ROCB. All water quality grab samples were analyzed for *E. coli* (MPN/100 mL), and approximately half were also analyzed for TSS (mg/L), total phosphorus (mg/L), and total nitrogen (mg/L).

#### *pH Analysis*

Water quality sonde data collected at 15-minute intervals from site ROCB show that the water quality standard for pH of an acceptable range of 6.0 to 8.5 pH was violated 0.00% of the time (0 out of 53,098 records) over the period of record.

A linear regression analysis was performed for 15-minute interval pH data. The results of the linear regression analysis show a slight negative slope ( $-1.166\text{E-}06$ ), which was significant at the  $p < 0.01$  level ( $p < 0.001$ ). This indicates that the likelihood of this decreasing pH relationship occurring by chance is very small. The negative slope of the line indicates that pH values are decreasing very slightly throughout this dataset. This rate of change is so small that changes in observed pH values would happen over several tens of thousands of measurements. If this relationship holds true with data collected over additional time periods, it would take over a year for a realized 0.01 decrease in pH value.

	<i>Coefficients</i>	<i>Standard Error</i>	<i>t Stat</i>	<i>P-value</i>
Intercept	7.019848198	0.001606556	4369.50104	0
Slope	-1.16648E-06	5.15523E-08	-22.62721167	8E-113



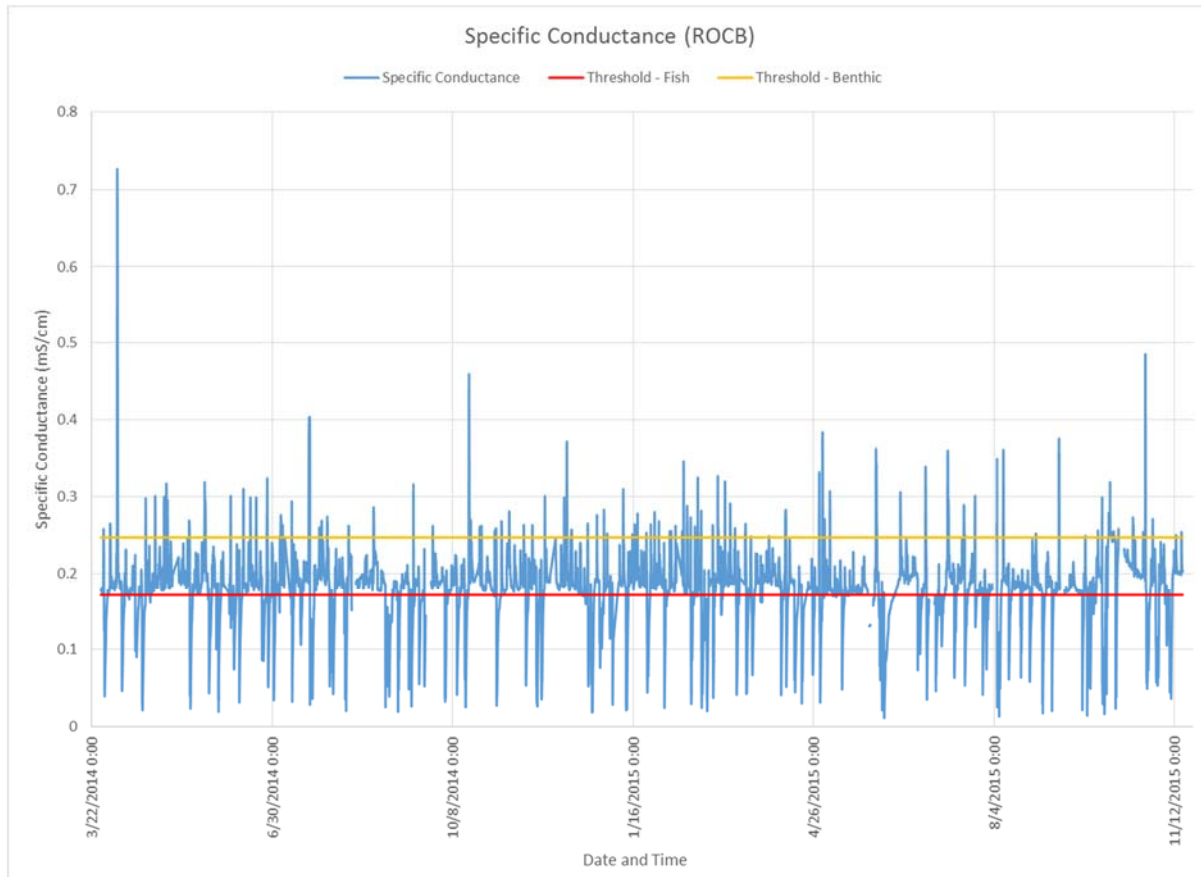
Monthly average pH and seasonal average pH were calculated for this site to investigate patterns and seasonality in the data. This created 21 monthly averages and seven seasonal averages. No patterns are evident in monthly average nor seasonal average pH.

### *Specific Conductance*

South Carolina does not have water quality criteria for specific conductance, which is a measure of dissolved inorganic ions such as chloride, nitrate, sulfate and phosphate anions and sodium, magnesium, calcium, iron, and aluminum cations. Morgan et al., 2007, found biological assemblage impairment thresholds of for biological impairment of 0.247 mS/cm for benthic macroinvertebrates and 0.171 mS/cm for fish in urban streams in Maryland. Rocky Branch is an urban stream so the impairment thresholds from Maryland data may be applicable. When compared against these values, the possible specific conductance impairment thresholds were exceeded in ROCB for benthic macroinvertebrate assemblage

4.35% of the time (2,318 records out of 53,246 total records), and for fish assemblage 74.99% of the time (39,931 records out of 53,246 total records).

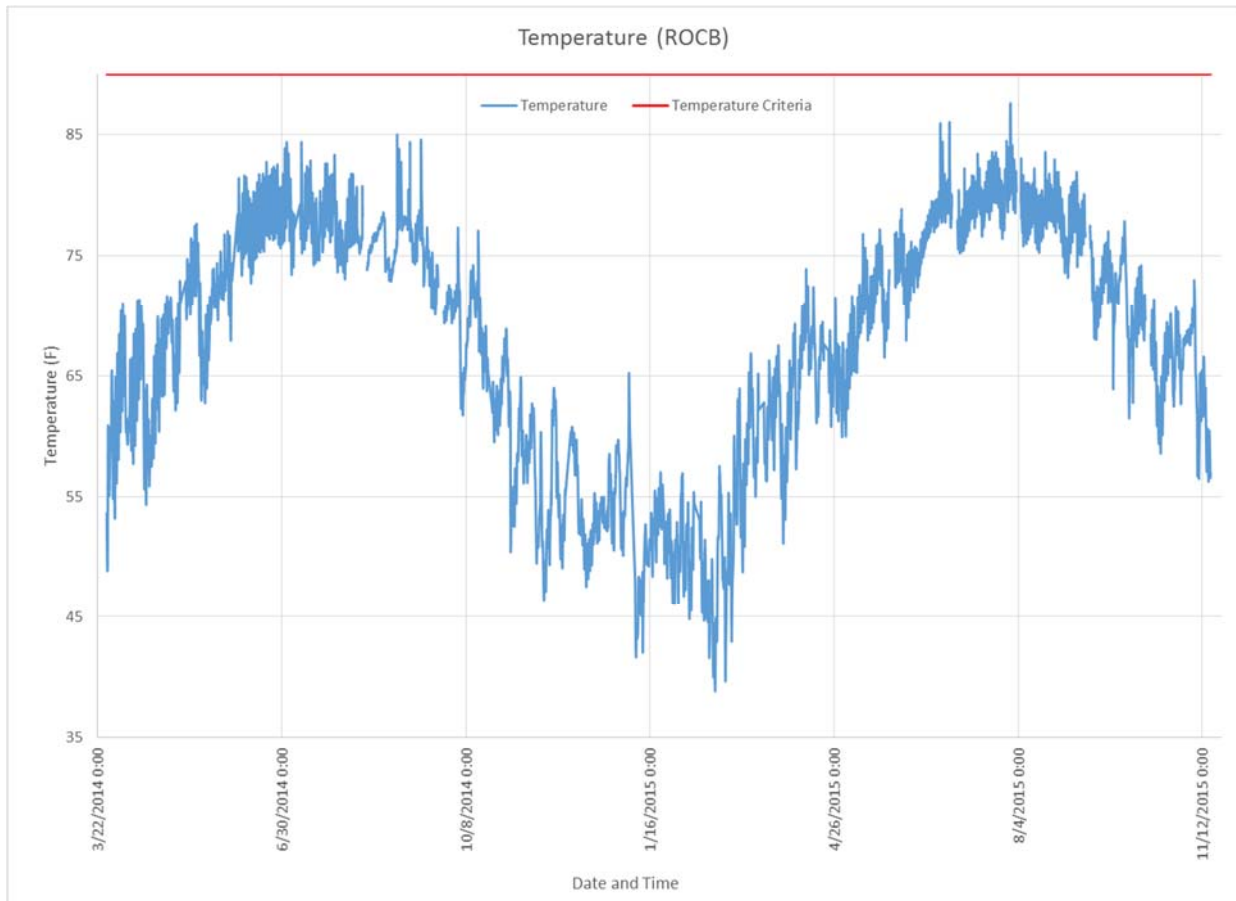
Site ROCB had lower maximum observed specific conductance values than ROCA, but had a higher percentage of values above the possible biological assemblage impairment thresholds. These data suggest that site ROCB has a chronic specific conductivity condition that may limit the ecological health of this portion of Rocky Branch.



### *Water Temperature*

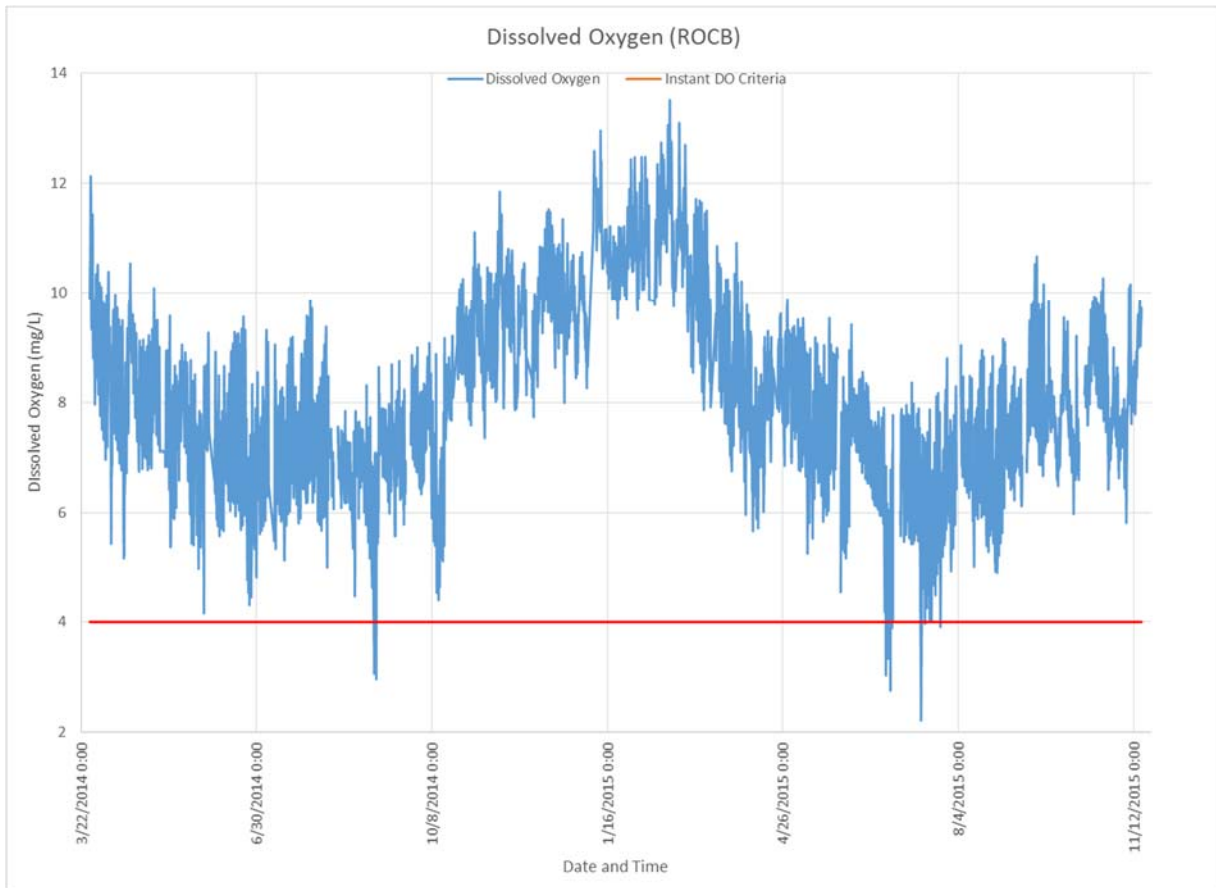
The water quality criteria for temperature of 90.0° F was not exceeded at ROCB. All temperature measurements were well below 90.0° F.

As expected, there is a seasonal and diurnal pattern to water temperature in Rocky Branch. The highest measured water temperatures occurred during the summer time. Summer is the time of the year with the highest air temperatures, and the greatest amount of solar radiation. These factors help warm water throughout the day. The highest temperatures measured each day were in the afternoon. Afternoon is usually the period of time with the highest air temperature, and sunlight has been warming the water and stream substrates throughout the day.



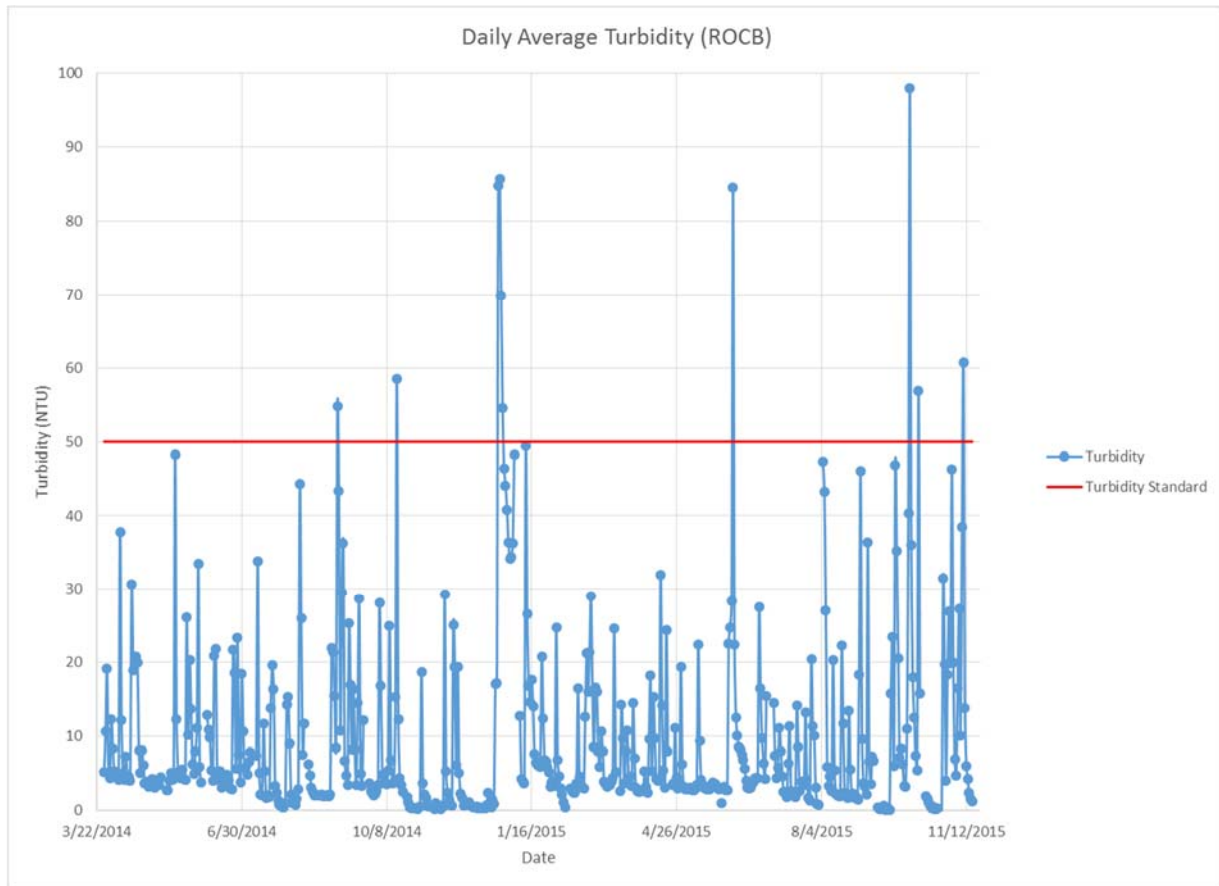
### *Dissolved Oxygen*

Water quality sonde data from site ROCB show that the instantaneous water quality standard for dissolved oxygen of 4.0 mg/L was violated 0.26% of the time (138 out of 53,138 records) over the period of record. Over the same period of time, the water quality standard for daily average dissolved oxygen of 5.0 mg/L was violated 0.89% of the time (5 out of 559 days). The daily criteria violations happened over a 4-day period from June 23<sup>rd</sup> through June 26<sup>th</sup>, 2015, and during July 13<sup>th</sup>, 2015.



### *Turbidity*

Water quality sonde data from site ROCB show that water quality standard for turbidity of 50 NTU was violated 3.58% of the time (1894 out of 52,836 records) over the period of record.



### *E. coli*

Water quality grab samples were collected at ROCB 16 times and analyzed for *E. coli*. These 16 samples were spread across 21 months, making statistical analysis of these data problematic. There are too few samples to perform a trend analysis. *E. coli* counts ranged from a high of '>24,196' MPN/100mL to a low of 285 MPN/100mL. The mean was  $6,361.3 \pm 3,893.5$  with a standard deviation of 7,306.7.

South Carolina's water quality standard for fecal coliform is a geometric mean of 200 MPN/100mL of five samples collected over a 30-day period. There is no 30-day period throughout the period of record for ROCB where at least five samples were collected. A comparison of means is not possible. The water quality criteria allow for a percentage criteria, where recreational uses are supported if less than 10% of samples exceed 400 MPN/100mL. At ROCB 81.25% of samples exceed 400 MPN/100mL.

### *TSS*

Water quality grab samples were collected at ROCB and analyzed for TSS 9 out of 16 (56.25%) sampling events. These nine TSS samples were collected during four days: three samples on May 15<sup>th</sup>, 2014; four samples on November 17<sup>th</sup>, 2014; one sample on February 2<sup>nd</sup>, 2015; and one sample on September 24<sup>th</sup>, 2015. The TSS data are too infrequent to allow for any robust statistical analysis. TSS concentrations

ranged from a high of 415 mg/L to a low of 1 mg/L. The mean concentration was  $93.17 \pm 100.43$  with a standard deviation of 130.66.

#### *Total Phosphorus*

Water quality grab samples were collected at ROCB and analyzed for total phosphorus (TP) 9 out of 16 (56.25%) sampling events. These nine TP samples were collected during four days: three samples on May 15<sup>th</sup>, 2014; four samples on November 17<sup>th</sup>, 2014; one sample on February 2<sup>nd</sup>, 2015; and one sample on September 24<sup>th</sup>, 2015. The TP data are too infrequent to allow for any robust statistical analysis. TP concentrations ranged from a high of 0.81 mg/L to a low of 0.093 mg/L. The mean concentration was  $0.29 \pm 0.17$  with a standard deviation of 0.22.

#### *Total Nitrogen*

Water quality grab samples were collected at ROCB and analyzed for total nitrogen (TN) 9 out of 16 (56.25%) sampling events. These nine TN samples were collected during four days: three samples on May 15<sup>th</sup>, 2014; four samples on November 17<sup>th</sup>, 2014; one sample on February 2<sup>nd</sup>, 2015; and one sample on September 24<sup>th</sup>, 2015. The TN data are too infrequent to allow for any robust statistical analysis. TN concentrations ranged from a high of 4.12 mg/L to a low of 0.72 mg/L. The mean concentration was  $1.84 \pm 0.82$  with a standard deviation of 1.07.

### **Recommendations to Improve Monitoring**

The following are KCI's recommendations to modify the City of Columbia's water quality monitoring of Rocky Branch:

#### *Site Locations*

- No suggested modifications. Two sites located longitudinally along the stream network are appropriate for a small stream such as this.

#### *Quality Control*

- If not already in place, prepare a quality assurance and quality control plan.
- Perform regular calibration and maintenance on data loggers and sondes. Keep a log of when maintenance is performed, and when data loggers or sondes are not deployed.
- Include log with water quality data to help interpret data gaps and suspect data records (e.g. negative turbidity, sudden jumps in pH to near buffer values). Maintenance log information could be stored in a comments field and associated with time intervals closest to maintenance activity.

#### *Parameters - pH, Specific Conductance, Water Temperature, Dissolved Oxygen, Turbidity*

- No suggested modifications to parameters collected via sonde. Collecting these parameters at 15-minute intervals produces a robust data record for analysis.
- Minimize gaps in the data record. Several data gaps from one to four days in duration exist in the data record. Out of 600 days in the data record analyzed, 42 days were missing data (7% of days).

Having back-up water quality sondes and other necessary equipment that can quickly replace broken or malfunctioning equipment will minimize data gaps in the future.

#### Parameter – *E. coli*

- Collect more frequent *E. coli* samples. Across the period of record available for analysis (March 27<sup>th</sup>, 2014 through November 17<sup>th</sup>, 2015) there were only 15 *E. coli* samples collected at site ROCA and 16 at ROCB. This paucity of *E. coli* data severely limited the analysis. The South Carolina water quality standard for *E. coli* is calculated using at least five samples collected over a 30-day period. Not once over the available period of record were samples collected that frequently. Future sampling should attempt to collect at least five samples over a 30-day period each quarter.
- Collect *E. coli* samples more frequently when recreational water contact is most likely. Humans are most likely to have recreational contact with the water during warm-weather periods (e.g. during the summer). Over two summers (Memorial Day to Labor Day) only one *E. coli* sample was collected. Future sample collection for *E. coli* should be scheduled to collect more samples during the summer season.
- Collect more *E. coli* samples across a range of stream flow/stage. In urban streams, storm events can affect bacteria concentrations through leaking or broken infrastructure as well as sanitary sewer overflows. More *E. coli* samples during storm events will allow for future analysis of baseflow *E. coli* concentrations versus stormflow concentrations.

#### Parameters – TSS, TP, and TN

- Determine the utility of collecting these parameters for the City's needs. Currently, TSS, TP, and TN data are collected too infrequently to calculate loads, detect trends, or accurately describe current conditions. For these data to be useful in future analysis, samples should be collected monthly at even intervals and during several storm events throughout the year.

#### Parameter - Copper

- Copper could be added as a parameter to water quality grab samples. Collecting copper data will allow the City to assess the contribution of Rocky Creek to the copper loading in the Congaree River.

#### Parameter - Mercury

- It is not recommended to add mercury in fish tissue as a parameter to be collected in Rocky Branch. Methylation occurs most frequently at the water-sediment interface in wetland and lentic systems. Methylation is the process where elemental mercury is converted to a bioavailable form by anaerobic bacteria. There are no lakes and very little to no wetlands on Rocky Branch so methylmercury accumulation in fish tissue is unlikely.

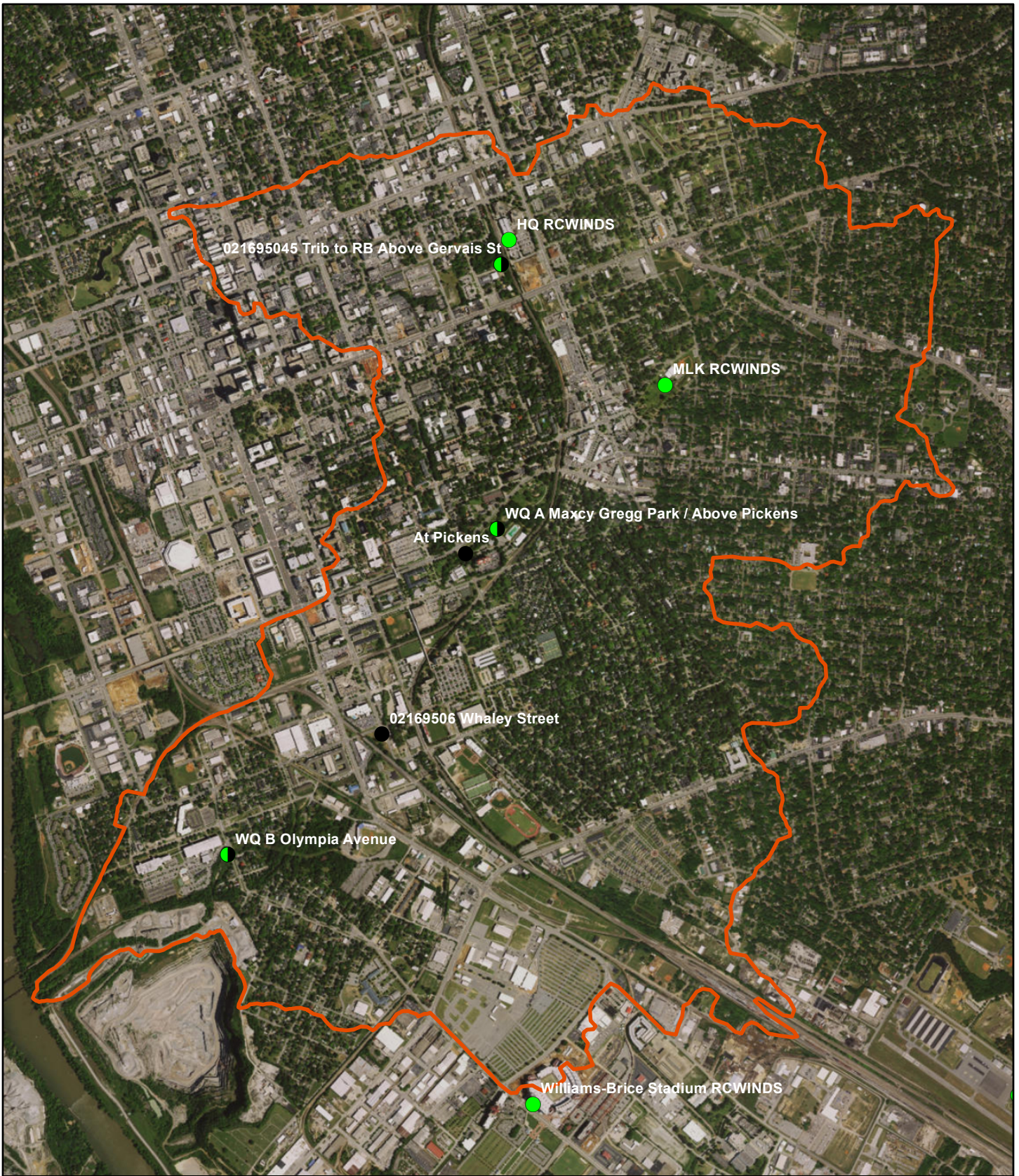
#### Parameter - Discharge

- Stage data collected at ROCA and ROCB could be converted to discharge following development of a stage-discharge rating curve relationship. The relationship can be calibrated and verified using

the nearby USGS station. Discharge would allow for additional calculation of loads for several parameters (e.g. nutrients, metals) given adequate density and frequency of sampling over time and with distribution of sampling events in both baseflow and stormflow periods.

## **References**

Morgan R.P., K.M. Kline, and S.F. Cushman. 2007. Relationships among nutrients, chloride, and biological indices in urban Maryland streams. *Urban Ecosystems* 10:153-177.



### Rocky Branch Watershed - Stream and Precipitation Gages

- Precipitation
- Stage
- Stage/Precipitation
- Watershed Boundary

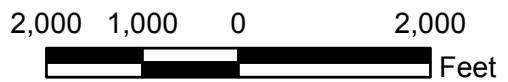


Image Source: USDA NAIP, 2015

---

Appendix C:  
Field Data Dictionary  
(Stream Cruising Effort)

---

## Rocky Branch Watershed Data Dictionary

February 4<sup>th</sup>, 2016

### Example Attribute

#### **Feature Type (point or line)**

Attributes (text entry \_\_\_ and *drop down menus*)

**Red** means default

#### **Site Data (point)**

Site ID \_\_\_\_\_

Team Members \_\_\_\_\_

Current Weather (drop down menu)

*Sun*

*Clouds*

*Rain*

*Snow*

Current Temperature \_\_\_\_\_

Rain Previous 24hr (drop down menu)

*Yes, No*

If yes, amount in inches \_\_\_\_\_

Rain Previous 48hr y/n (drop down menu)

*Yes, No*

If yes, amount in inches \_\_\_\_\_

Rain Previous 72hr y/n (drop down menu)

*Yes, No*

If yes, amount in inches \_\_\_\_\_

#### **Channel Alteration (line)**

Site ID \_\_\_\_\_

Type (drop down menu)

*Concrete*

*Riprap*

*Gabion Basket*

*Earthen Channel*

*Channelization/Straightening*

*Road Culvert*

*Other (fill out comment)*

Comment on Type \_\_\_\_\_

Bottom Width \_\_\_\_\_

Pipe Diameter (inside) in Inches \_\_\_\_\_

Longitudinal Length in Feet \_\_\_\_\_

Alteration Location (drop down menu)

*Bed*

*Banks*

*Bed and Banks*

Flow Regime (drop down menu)

*Perennial*

*Intermittent*

*Ephemeral*

Significant vegetation in channel (drop down menu)

*Yes, No*

Significant Aggradation (drop down menu)

*Yes, No*

Significant Degradation (drop down menu)

*Yes, No*

Comment on Condition \_\_\_\_\_

Part of Road Crossing (drop down menu)

*Yes, No*

Severity (drop down menu)

*Very Severe*

*Severe*

*Moderate*

*Minor*

*Very Minor*

Estimated Difficulty to Correct (drop down menu)

*Very Hard*

*Hard*

*Moderate*

*Easy*

Very Easy  
Access (drop down menu)  
Very Hard  
Hard  
Moderate  
Easy  
Very Easy  
Photos (attached to feature)  
Comments\_\_\_\_\_

**Erosion Site (line)**

Site ID \_\_\_\_\_  
Type (drop down menu)  
Headcutting  
Downcutting  
Widening  
Other (fill out comment)  
Comment \_\_\_\_\_  
Suspected Cause (drop down menu)  
Pipe Outfall  
Bend at steep slope  
Landuse change  
Channel encroachment  
Unknown  
Other (fill out comment)  
Comment \_\_\_\_\_  
Longitudinal length in feet \_\_\_\_\_  
Average height in feet \_\_\_\_\_  
Left Land Use (Dominant land use on left side within  
50 feet)  
(drop down menu)  
Residential Development  
Commercial Development

Park/Open Space  
Paved  
Small Trees/Shrubs  
Forest  
Other (fill out comment)  
Comment \_\_\_\_\_  
Right Land Use (Dominant land use on right side  
within 50 feet)  
(drop down menu)  
Residential Development  
Commercial Development  
Park/Open Space  
Paved  
Small Trees/Shrubs  
Forest  
Other (fill out comment)  
Comment \_\_\_\_\_  
Infrastructure Possibly Threatened (drop down menu)  
Yes, *No*, Unknown  
Comment on Threat \_\_\_\_\_  
Predominant Bank Material (drop down menu)  
Clay  
*Silt*  
Sand  
Gravel  
Cobble  
Boulder  
Bedrock  
Stratification of Soils In bank (drop down menu)  
Yes, *no*  
Bank Angle (drop down menu)  
0 – 20 degrees  
21 – 60 degrees

61 – 80 degrees  
81 – 90 degrees  
91 - 119 degrees  
>119 degrees

Severity (drop down menu)

*Very Severe*  
*Severe*  
*Moderate*  
*Minor*  
*Very Minor*

Estimated Difficulty to Correct (drop down menu)

*Very Hard*  
*Hard*  
*Moderate*  
*Easy*  
*Very Easy*

Access (drop down menu)

*Very Hard*  
*Hard*  
*Moderate*  
*Easy*  
*Very Easy*

Photos (attached to feature)

Comments\_\_\_\_\_

**Exposed Pipes (point)**

Site ID\_\_\_\_\_

Type (drop down menu)

*Manhole Stack*  
*Exposed along stream bank*  
*Pipe Crossing Channel*  
*Spanning Above Channel*  
*Other (fill out comment)*

Comment on Type\_\_\_\_\_

Material (drop down menu)

*Concrete*  
*Brick*  
*Smooth Metal*  
*Corrugated Metal*  
*Corrugated Plastic*  
*Other (fill out comment)*

Comment on Material\_\_\_\_\_

Pipe Diameter (Inside) in Inches\_\_\_\_\_

Length of Pipe Exposed in Feet\_\_\_\_\_

Encasement (drop down menu)

*Yes, No, Unknown*

Utility Type (drop down menu)

*Sanitary*  
*Gas*  
*Water*  
*Other (fill out comment)*

Comment on Type\_\_\_\_\_

Evidence of Discharge (drop down menu)

*Yes, No, Unknown*

*Color and Odor*\_\_\_\_\_

Severity (drop down menu)

*Very Severe*  
*Severe*  
*Moderate*  
*Minor*  
*Very Minor*

Estimated Difficulty to Correct (drop down menu)

*Very Hard*  
*Hard*  
*Moderate*  
*Easy*

*Very Easy*  
Access (drop down menu)  
*Very Hard*  
*Hard*  
*Moderate*  
*Easy*  
*Very Easy*  
Photos (attached to feature)  
Comments\_\_\_\_\_

**Pipe Outfalls (point)**

Site ID \_\_\_\_\_  
Included in City GIS Layers? (drop down menu)  
*Yes, No*  
Type (drop down menu)  
*Storm Water Outfall*  
*Sewage Plant Discharge*  
*Industrial Discharge*  
*Overflow Pipe*  
*Agricultural Drainage Pipe*  
*Residential (Roof Drains)*  
*Unknown (fill out comment)*  
Comment on Type \_\_\_\_\_  
Material (drop down menu)  
*Concrete*  
*Smooth metal*  
*Corrugated Metal*  
*Corrugated Plastic*  
*Other (fill out comment)*  
Comment on Material \_\_\_\_\_  
Pipe Diameter (Inside) in Inches \_\_\_\_\_  
Location (drop down menu)  
*Left Bank*

*Right Bank*  
*Head of Channel*  
Headwall present? (drop down menu)  
*Yes, no*  
End section present? (drop down menu)  
*Yes, no*  
Outfall Structure in obvious need of repairs? (drop  
down menu)  
*Yes, No*  
Outfall Channel Width in Feet \_\_\_\_\_  
Outfall Channel Material (drop down menu)  
*Concrete*  
*Earthen*  
*Riprap*  
*Gabion*  
*Other (fill out comment)*  
Comment on Channel Material \_\_\_\_\_  
Evidence of Discharge (drop down menu)  
*Yes, No*  
Discharge Color \_\_\_\_\_  
Discharge Odor \_\_\_\_\_  
Evidence of Erosion (drop down menu)  
*Yes, No*  
Erosion Type (drop down menu)  
*Headcutting*  
*Downcutting*  
*Widening*  
*Other (fill out comment)*  
Comment on Erosion Type \_\_\_\_\_  
Distance from mainstem channel in Feet \_\_\_\_\_  
Vertical Drop outfall invert to mainstem invert in  
Feet \_\_\_\_\_  
Severity (drop down menu)

*Very Severe*  
*Severe*  
*Moderate*  
*Minor*  
*Very Minor*  
Estimated Difficulty to Correct (drop down menu)  
*Very Hard*  
*Hard*  
*Moderate*  
*Easy*  
*Very Easy*  
Access (drop down menu)  
*Very Hard*  
*Hard*  
*Moderate*  
*Easy*  
*Very Easy*  
Photos (attached to feature)  
Comments\_\_\_\_\_

**Possible Fish Barrier (point)** (Permanent only, Greater than 6" drop in WSEL, water depth less than 1", water moving too fast, Assessed at baseflow)

Site ID\_\_\_\_\_

Blockage Extent (drop down menu)  
*Total*  
*Partial*

Type (drop down menu)  
*Dam*  
*Road Crossing*  
*Pipe Crossing*  
*Natural Falls*  
*Beaver Dam*

*Channelized Stream Section*  
*Other (fill out comment)*  
Comment on Type \_\_\_\_\_  
Blockage Because (Choose Most Important) (drop down menu)

*Too high (>6", Height)*  
*Too Shallow (<1")*  
*Too Fast*  
Water Drop in Inches\_\_\_\_\_

Water Depth in Feet\_\_\_\_\_

Severity (drop down menu)  
*Very Severe*  
*Severe*  
*Moderate*  
*Minor*  
*Very Minor*

Estimated Difficulty to Correct (drop down menu)  
*Very Hard*  
*Hard*  
*Moderate*  
*Easy*  
*Very Easy*

Access (drop down menu)  
*Very Hard*  
*Hard*  
*Moderate*  
*Easy*  
*Very Easy*

Photos (attached to feature)  
Comments\_\_\_\_\_

**Inadequate Forest Buffer (line)** (<50 feet forest buffer)  
Site ID\_\_\_\_\_

Existing Buffer Width - Right \_\_\_\_\_

Existing Buffer Width - Left \_\_\_\_\_

Landuse Right Bank (drop down menu)

*Residential Building*

*Commercial Building*

*Park/Open Space*

*Paved*

*Small Trees/Shrubs*

*Forest*

*Other (fill out comment)*

Landuse Left Bank (drop down menu)

*Residential Building*

*Commercial Building*

*Park/Open Space*

*Paved*

*Small Trees/Shrubs*

*Forest*

*Other (fill out comment)*

Comment on Landuse \_\_\_\_\_

Recent Buffer Establishment (drop down menu)

*Yes, No*

Comment on Recent Establishment \_\_\_\_\_

Possible Opportunity for Tree Planting? (drop down menu)

*Yes, No*

Severity (drop down menu)

*Very Severe*

*Severe*

*Moderate*

*Minor*

*Very Minor*

Estimated Difficulty to Correct (drop down menu)

*Very Hard*

*Hard*

*Moderate*

*Easy*

*Very Easy*

Access (drop down menu)

*Very Hard*

*Hard*

*Moderate*

*Easy*

*Very Easy*

Wetland Potential (drop down menu)

*Very Hard*

*Hard*

*Moderate*

*Easy*

*Very Easy*

Photos (attached to feature)

Comments \_\_\_\_\_

**In/Near Stream Construction (Point)**

Site ID \_\_\_\_\_

Type of Activity (drop down menu)

*Road Construction*

*Culvert/Bridge work*

*Utility Work*

*Clearing*

*Bank Stabilization*

*Residential Development*

*Industrial Development*

*Other (fill out comment)*

Comment on Activity Type \_\_\_\_\_

Photos (attached to feature)

Comments \_\_\_\_\_

**Trash Dumping (Point)**

- Site ID \_\_\_\_\_
- Type of Trash (drop down menu)
  - Residential*
  - Industrial*
  - Floatables*
  - Tires*
  - Construction Waste*
- Distribution (drop down menu)
  - Single Site*
  - Multiple Sites*
- Location (drop down menu)
  - Instream*
  - Bank*
  - Floodplain*
- Amount of Trash (Estimate number of pickup loads) \_\_\_\_\_
- Volunteer Clean-up Potential? (drop down menu)
  - Yes, No*
- Severity (drop down menu)
  - Very Severe*
  - Severe*
  - Moderate*
  - Minor*
  - Very Minor*
- Estimated Difficulty to Correct (drop down menu)
  - Very Hard*
  - Hard*
  - Moderate*
  - Easy*

- Very Easy*
- Access (drop down menu)
  - Very Hard*
  - Hard*
  - Moderate*
  - Easy*
  - Very Easy*
- Photos (attached to feature)
- Comments \_\_\_\_\_

**Unusual Condition (Point)**

- Site ID \_\_\_\_\_
- Type (drop down menu)
  - Unusual odor*
  - Excessive algae/scum*
  - Unusual water color/clarity*
  - Excessive bacteria indicators*
  - Stream restoration by landowner*
  - Plantings*
  - Other (fill out comment)*
- Comment on Type \_\_\_\_\_
- Severity (drop down menu)
  - Very Severe*
  - Severe*
  - Moderate*
  - Minor*
  - Very Minor*
- Estimated Difficulty to Correct (drop down menu)
  - Very Hard*
  - Hard*
  - Moderate*
  - Easy*
  - Very Easy*

Access (drop down menu)

*Very Hard*

*Hard*

*Moderate*

*Easy*

*Very Easy*

Photos (attached to feature)

Comments\_\_\_\_\_

### **Unmanaged Runoff (Point)**

Date\_\_\_\_\_

Team\_\_\_\_\_

Site\_\_\_\_\_

Time\_\_\_\_\_

Source (drop down menu)

*Parking Lot*

*Road*

*Commercial Development*

*Other (fill out comment)*

Comment on Source\_\_\_\_\_

Potential BMP Opportunity?

*Yes, **No***

Severity (drop down menu)

*Very Severe*

*Severe*

*Moderate*

*Minor*

*Very Minor*

Estimated Difficulty to Correct (drop down menu)

*Very Hard*

*Hard*

*Moderate*

*Easy*

*Very Easy*

Access (drop down menu)

*Very Hard*

*Hard*

*Moderate*

*Easy*

*Very Easy*

Photos (attached to feature)

Comments\_\_\_\_\_

### **Bedrock (point)**

Site ID\_\_\_\_\_

Location (drop down menu)

*In-Channel*

*Right Bank*

*Left Bank*

*Other\_\_\_\_\_*

Associated Bed Feature (drop down menu)

*Pool*

*Riffle*

*Run*

*Cascade*

*Glide*

*Other (fill out comment)*

Photos (attached to feature)

Comments\_\_\_\_\_

### **Representative Photo Site (point)**

Site ID\_\_\_\_\_

Valley/Channel Change Type (drop down menu)

*Entrenchment*

*Buffer Condition*

*Channel Width*

*Bank height*

*Floodplain*

*Valley*

*Sinosity*

*Bed Material*

*Other* (fill out comment)

Photos (attached to feature)

Comments \_\_\_\_\_

**Habitat Assessment (point) – Based on EPA RBP**

(See pages 11 and 12 for descriptions of conditions categories)

Site ID \_\_\_\_\_

Bed Particle Size - % clay \_\_\_\_\_

Bed Particle Size - % silt \_\_\_\_\_

Bed Particle Size - % sand \_\_\_\_\_

Bed Particle Size - % gravel \_\_\_\_\_

Bed Particle Size - % cobble \_\_\_\_\_

Bed Particle Size - % boulder \_\_\_\_\_

Bed Particle Size - % bedrock \_\_\_\_\_

Bed Particle Size - % concrete \_\_\_\_\_

Epifaunal Substrate/Available Cover (0-20) \_\_\_\_\_

Embeddedness (0-20) \_\_\_\_\_

Velocity/Depth Regime (0-20) \_\_\_\_\_

Sediment Deposition (0-20) \_\_\_\_\_

Channel Flow Status (0-20) \_\_\_\_\_

Channel Alteration (0-20) \_\_\_\_\_

Frequency of Riffles (or bends) (0-20) \_\_\_\_\_

Bank Stability (Right) (0-10) \_\_\_\_\_

Bank Stability (Left) (0-10) \_\_\_\_\_

Vegetative Protection (Right) (0-10) \_\_\_\_\_

Vegetative Protection (Left) (0-10) \_\_\_\_\_

Riparian Vegetative Width (Right) (0-10) \_\_\_\_\_

Riparian Vegetative Width (Left) (0-10) \_\_\_\_\_

Trash Rating (0-20)

Percent Shading (to nearest 10%, assuming leaf on)

Photos (attached to feature)

Comments \_\_\_\_\_

**Restoration Recommendation (polygon)**

Site ID \_\_\_\_\_

Severity (drop down menu)

*Very Severe*

*Severe*

*Moderate*

*Minor*

*Very Minor*

Estimated Difficulty to Correct (drop down menu)

*Very Hard*

*Hard*

*Moderate*

*Easy*

*Very Easy*

Access (drop down menu)

*Very Hard*

*Hard*

*Moderate*

*Easy*

*Very Easy*

Potential Constraint (select primary concern)

*Utilities*

*Existing infrastructure*

*Existing landuse*

*Access*

*Resource Impacts*

*Other* (fill out comment)

Comment on Constraints \_\_\_\_\_

Potential for Public Outreach and/or greenway  
connection

*Yes, no*

Photos (attached to feature)

Comments\_\_\_\_\_

Habitat Parameter	Condition Category			
	Optimal	Suboptimal	Marginal	Poor
<b>1. Epifaunal Substrate/ Available Cover</b>	Greater than 70% of substrate favorable for epifaunal colonization and fish cover; mix of snags, submerged logs, undercut banks, cobble or other stable habitat and at stage to allow full colonization potential (i.e., logs/snags that are <u>not</u> new fall and not transient).	40-70% mix of stable habitat; well-suited for full colonization potential; adequate habitat for maintenance of populations; presence of additional substrate in the form of newfall, but not yet prepared for colonization (may rate at high end of scale).	20-40% mix of stable habitat; habitat availability less than desirable; substrate frequently disturbed or removed.	Less than 20% stable habitat; lack of habitat is obvious; substrate unstable or lacking.
SCORE	20 19 18 17 16	15 14 13 12 11	10 9 8 7 6	5 4 3 2 1 0
<b>2. Embeddedness</b>	Gravel, cobble, and boulder particles are 0-25% surrounded by fine sediment. Layering of cobble provides diversity of niche space.	Gravel, cobble, and boulder particles are 25-50% surrounded by fine sediment.	Gravel, cobble, and boulder particles are 50-75% surrounded by fine sediment.	Gravel, cobble, and boulder particles are more than 75% surrounded by fine sediment.
SCORE	20 19 18 17 16	15 14 13 12 11	10 9 8 7 6	5 4 3 2 1 0
<b>3. Velocity/Depth Regime</b>	All four velocity/depth regimes present (slow-deep, slow-shallow, fast-deep, fast-shallow). (Slow is < 0.3 m/s, deep is > 0.5 m.)	Only 3 of the 4 regimes present (if fast-shallow is missing, score lower than if missing other regimes).	Only 2 of the 4 habitat regimes present (if fast-shallow or slow-shallow are missing, score low).	Dominated by 1 velocity/depth regime (usually slow-deep).
SCORE	20 19 18 17 16	15 14 13 12 11	10 9 8 7 6	5 4 3 2 1 0
<b>4. Sediment Deposition</b>	Little or no enlargement of islands or point bars and less than 5% of the bottom affected by sediment deposition.	Some new increase in bar formation, mostly from gravel, sand or fine sediment; 5-30% of the bottom affected; slight deposition in pools.	Moderate deposition of new gravel, sand or fine sediment on old and new bars; 30-50% of the bottom affected; sediment deposits at obstructions, constrictions, and bends; moderate deposition of pools prevalent.	Heavy deposits of fine material, increased bar development; more than 50% of the bottom changing frequently; pools almost absent due to substantial sediment deposition.
SCORE	20 19 18 17 16	15 14 13 12 11	10 9 8 7 6	5 4 3 2 1 0
<b>5. Channel Flow Status</b>	Water reaches base of both lower banks, and minimal amount of channel substrate is exposed.	Water fills >75% of the available channel; or <25% of channel substrate is exposed.	Water fills 25-75% of the available channel, and/or riffle substrates are mostly exposed.	Very little water in channel and mostly present as standing pools.
SCORE	20 19 18 17 16	15 14 13 12 11	10 9 8 7 6	5 4 3 2 1 0
<b>6. Channel Alteration</b>	Channelization or dredging absent or minimal; stream with normal pattern.	Some channelization present, usually in areas of bridge abutments; evidence of past channelization, i.e., dredging, (greater than past 20 yr) may be present, but recent channelization is not present.	Channelization may be extensive; embankments or shoring structures present on both banks; and 40 to 80% of stream reach channelized and disrupted.	Banks shored with gabion or cement; over 80% of the stream reach channelized and disrupted. Instream habitat greatly altered or removed entirely.
SCORE	20 19 18 17 16	15 14 13 12 11	10 9 8 7 6	5 4 3 2 1 0

Parameters to be evaluated in sampling reach

Habitat Parameter	Condition Category				
	Optimal	Suboptimal	Marginal	Poor	
<b>7. Frequency of Riffles (or bends)</b>	Occurrence of riffles relatively frequent; ratio of distance between riffles divided by width of the stream <7:1 (generally 5 to 7); variety of habitat is key. In streams where riffles are continuous, placement of boulders or other large, natural obstruction is important.	Occurrence of riffles infrequent; distance between riffles divided by the width of the stream is between 7 to 15.	Occasional riffle or bend; bottom contours provide some habitat; distance between riffles divided by the width of the stream is between 15 to 25.	Generally all flat water or shallow riffles; poor habitat; distance between riffles divided by the width of the stream is a ratio of >25.	
	SCORE	20 19 18 17 16	15 14 13 12 11	10 9 8 7 6	5 4 3 2 1 0
<b>8. Bank Stability (score each bank)</b>  Note: determine left or right side by facing downstream.	Banks stable; evidence of erosion or bank failure absent or minimal; little potential for future problems. <5% of bank affected.	Moderately stable; infrequent, small areas of erosion mostly healed over. 5-30% of bank in reach has areas of erosion.	Moderately unstable; 30-60% of bank in reach has areas of erosion; high erosion potential during floods.	Unstable; many eroded areas; "raw" areas frequent along straight sections and bends; obvious bank sloughing; 60-100% of bank has erosional scars.	
	SCORE ___ (LB)	Left Bank 10 9	8 7 6	5 4 3	2 1 0
	SCORE ___ (RB)	Right Bank 10 9	8 7 6	5 4 3	2 1 0
<b>9. Vegetative Protection (score each bank)</b>	More than 90% of the streambank surfaces and immediate riparian zone covered by native vegetation, including trees, understory shrubs, or nonwoody macrophytes; vegetative disruption through grazing or mowing minimal or not evident; almost all plants allowed to grow naturally.	70-90% of the streambank surfaces covered by native vegetation, but one class of plants is not well-represented; disruption evident but not affecting full plant growth potential to any great extent; more than one-half of the potential plant stubble height remaining.	50-70% of the streambank surfaces covered by vegetation; disruption obvious; patches of bare soil or closely cropped vegetation common; less than one-half of the potential plant stubble height remaining.	Less than 50% of the streambank surfaces covered by vegetation; disruption of streambank vegetation is very high; vegetation has been removed to 5 centimeters or less in average stubble height.	
	SCORE ___ (LB)	Left Bank 10 9	8 7 6	5 4 3	2 1 0
	SCORE ___ (RB)	Right Bank 10 9	8 7 6	5 4 3	2 1 0
<b>10. Riparian Vegetative Zone Width (score each bank riparian zone)</b>	Width of riparian zone >18 meters; human activities (i.e., parking lots, roadbeds, clear-cuts, lawns, or crops) have not impacted zone.	Width of riparian zone 12-18 meters; human activities have impacted zone only minimally.	Width of riparian zone 6-12 meters; human activities have impacted zone a great deal.	Width of riparian zone <6 meters; little or no riparian vegetation due to human activities.	
	SCORE ___ (LB)	Left Bank 10 9	8 7 6	5 4 3	2 1 0
	SCORE ___ (RB)	Right Bank 10 9	8 7 6	5 4 3	2 1 0

Habitat Parameter	Optimal 16-20	Sub-Optimal 11-15	Marginal 6-10	Poor 0-5
<b>Trash Rating</b>	Little or no human refuse visible from stream channel or riparian zone	Refuse present in minor amounts	Refuse present in moderate amounts	Refuse abundant and unsightly

---

# Appendix D: Design Solutions

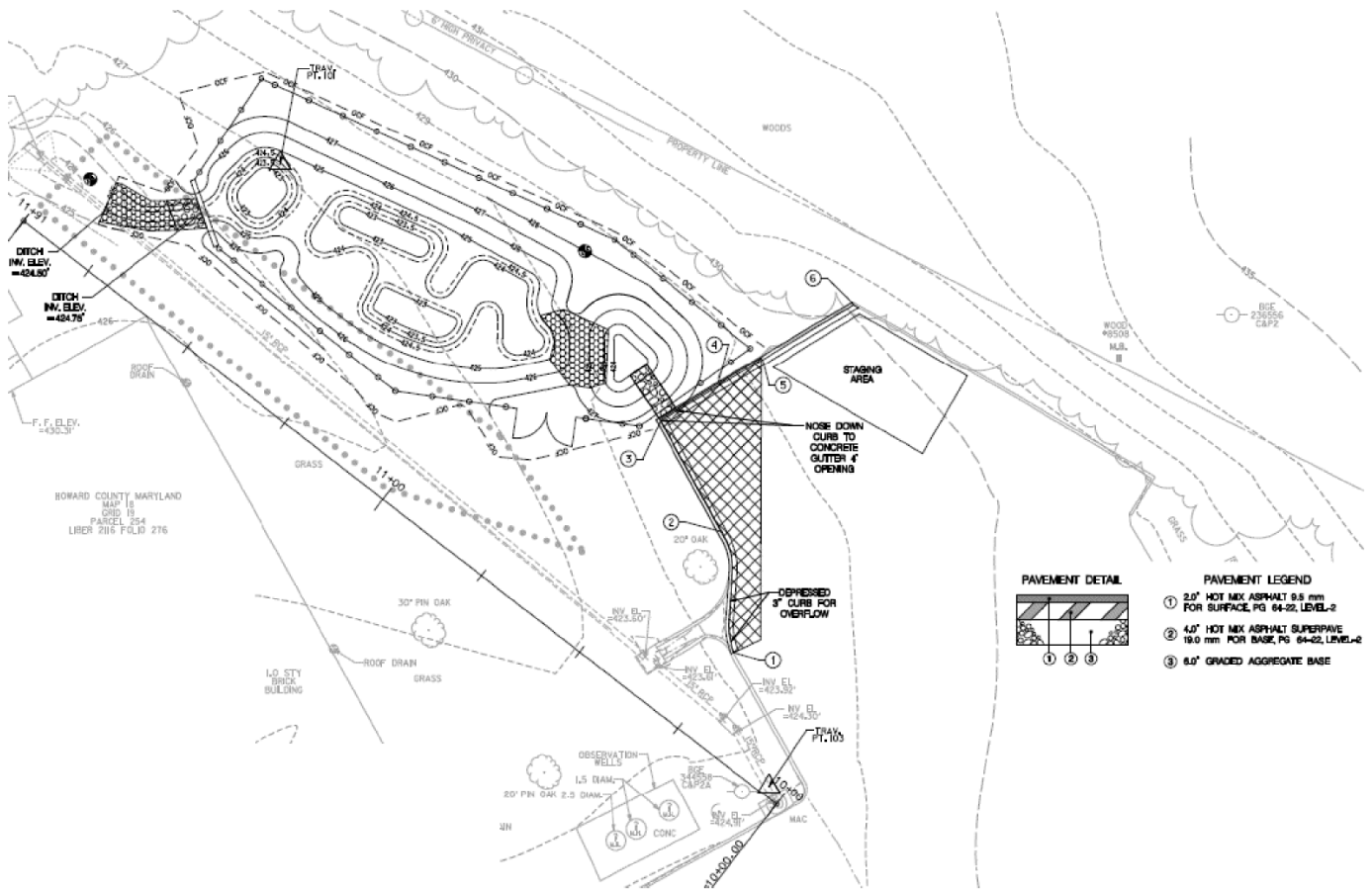
---

---

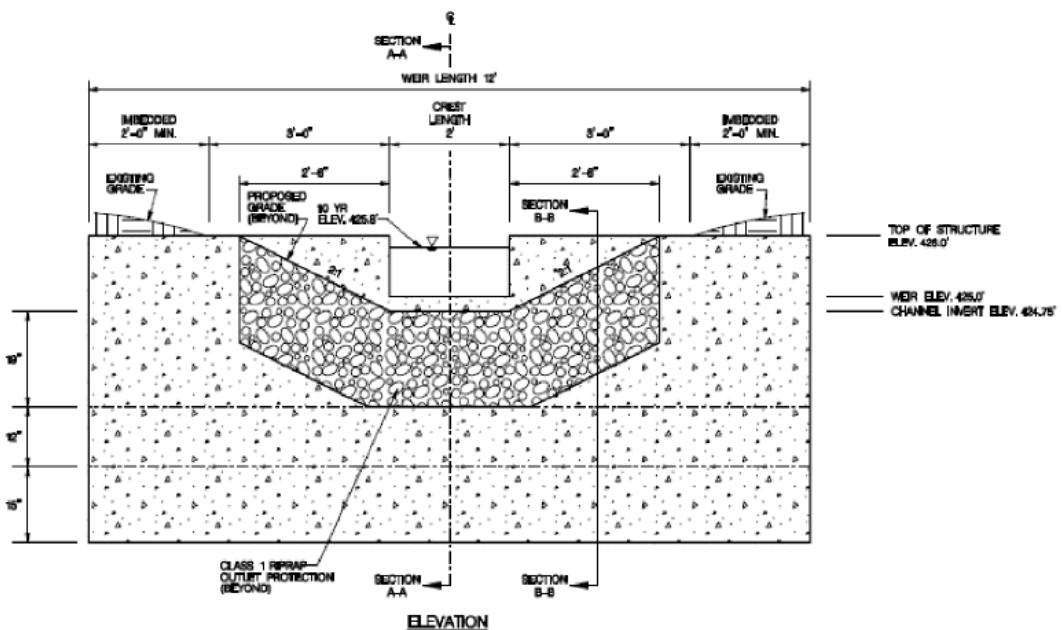
# Appendix D1: Typical Treatments

---

# Stormwater Management Retrofit

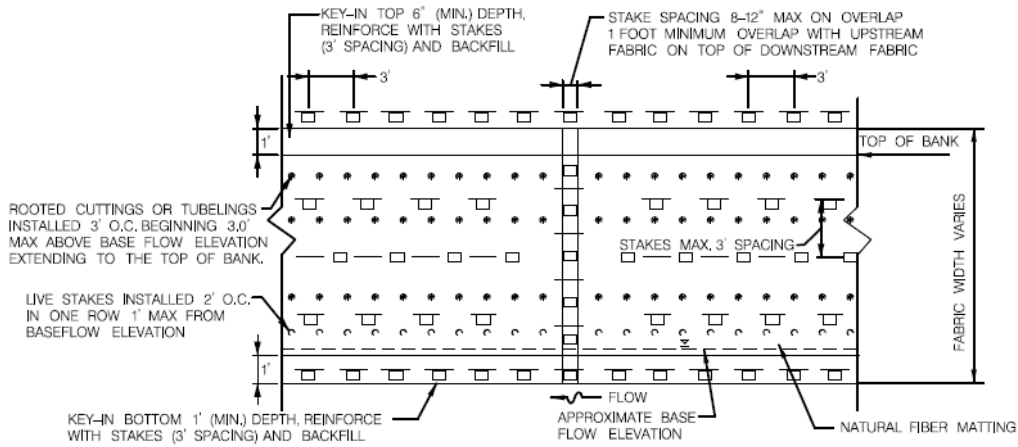


Stormwater Management Retrofit Plan View



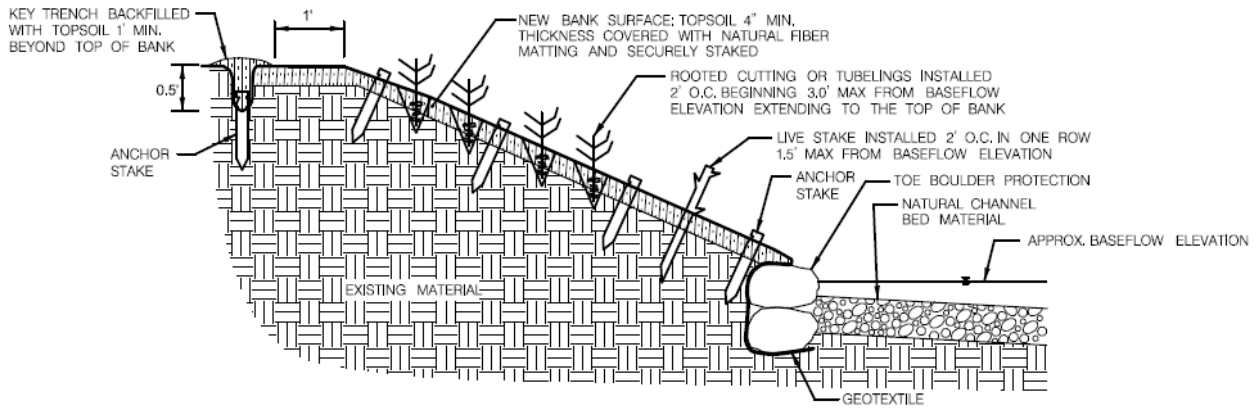
Stormwater Management Retrofit Cross Section

# Stream Restoration: Typical Bank Stabilization



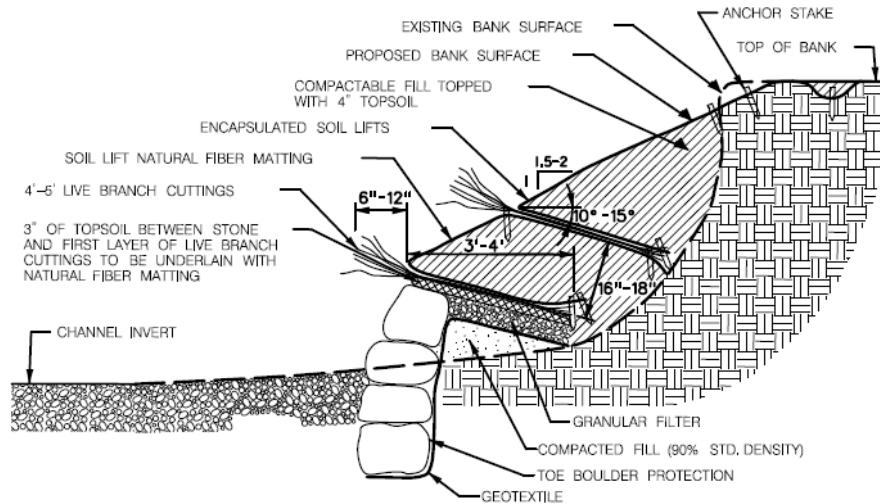
**NATURAL FIBER MATTING – PLAN VIEW**

NOT TO SCALE



**TOE BOULDER PROTECTION TYPICAL**

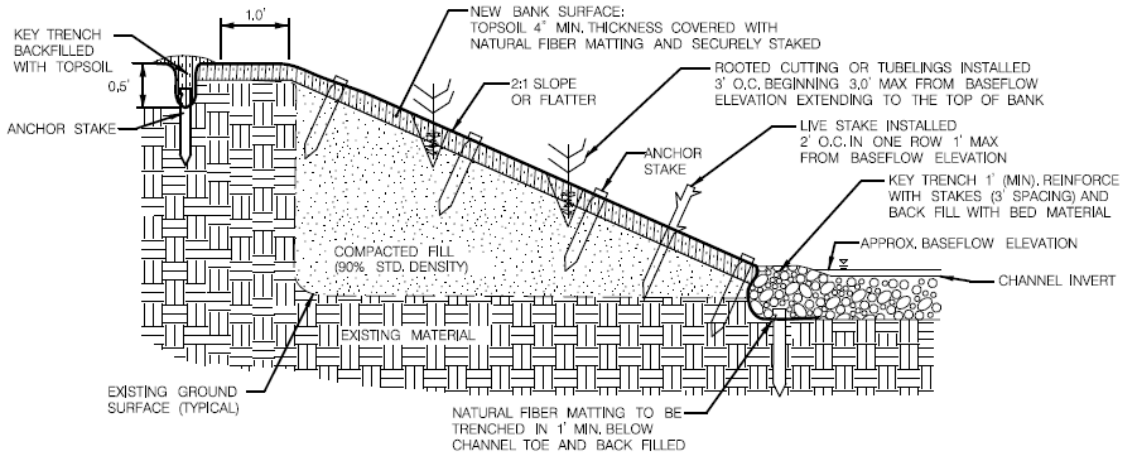
NOT TO SCALE



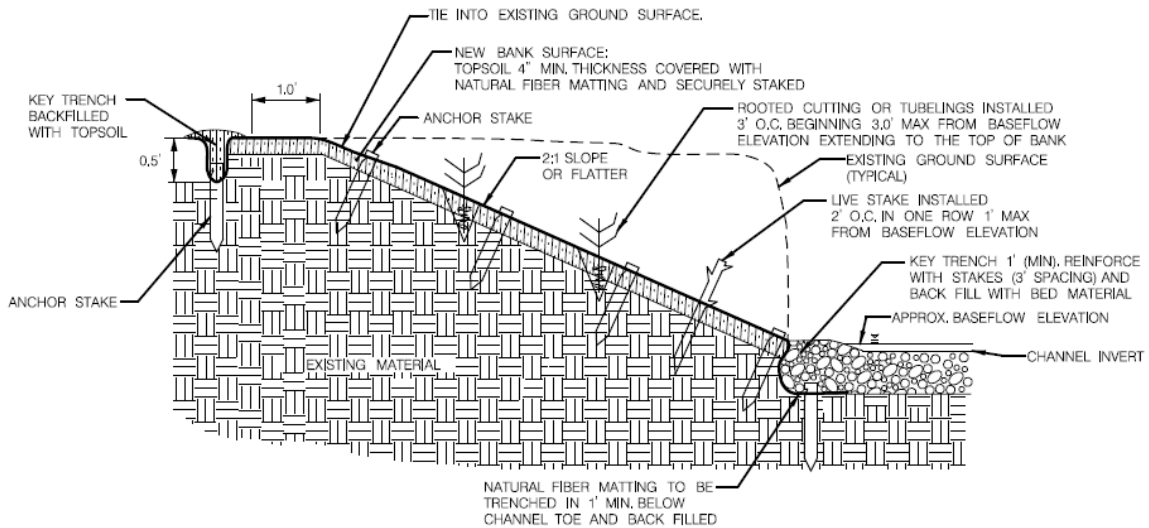
**TOE BOULDER PROTECTION WITH BRANCH LAYERING TYPICAL**

(NOT TO SCALE)

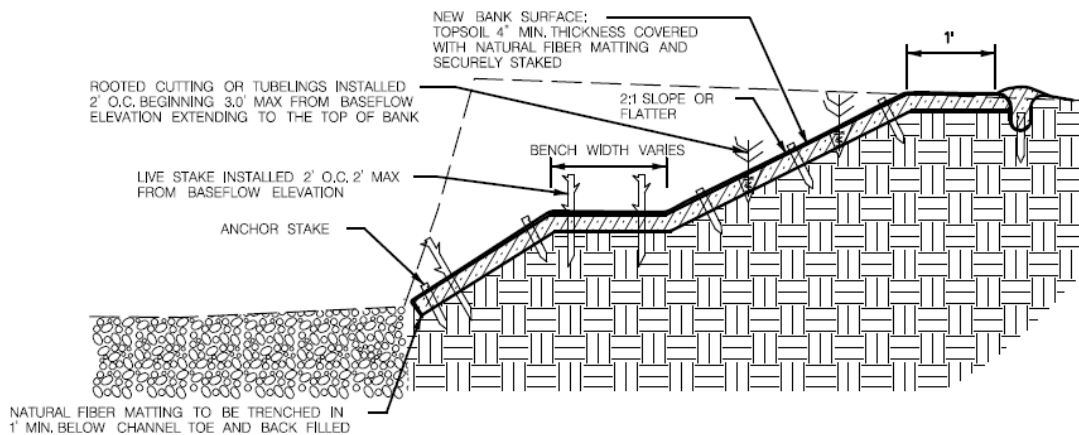
# Stream Restoration: Typical Bank Stabilization



**TYPICAL STREAMBANK STABILIZATION IN FILL**  
NOT TO SCALE

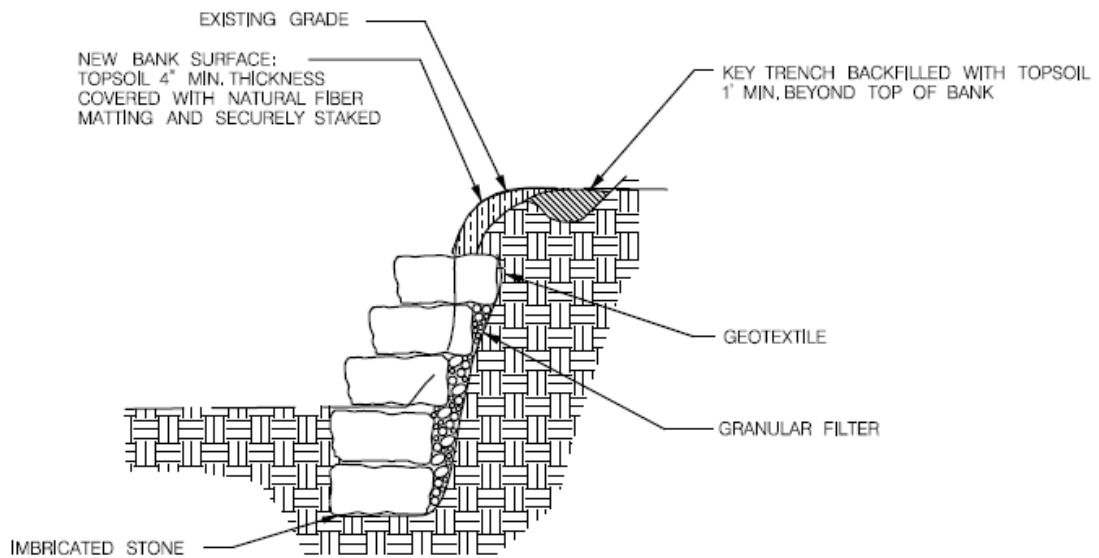


**TYPICAL STREAMBANK STABILIZATION IN CUT**  
NOT TO SCALE



**TYPICAL STREAMBANK STABILIZATION WITH FLOODPLAIN BENCH**  
NOT TO SCALE

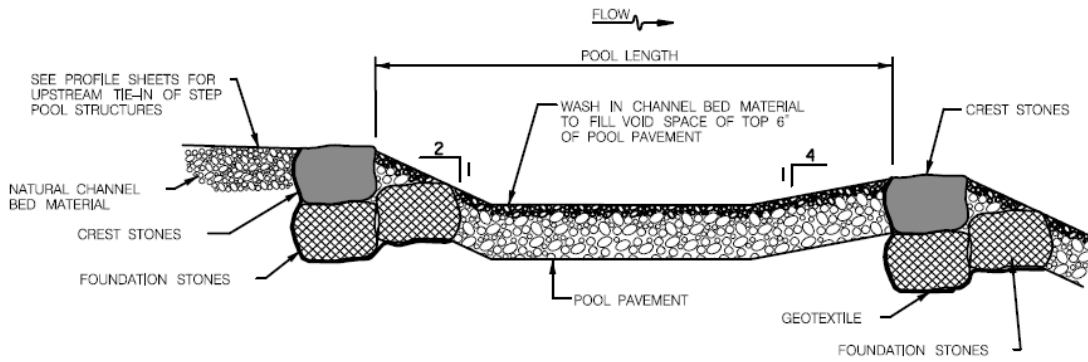
# Stream Restoration: Typical Bank Stabilization



IMBRICATED STONE WALL CHANNEL PROTECTION-SECTION VIEW

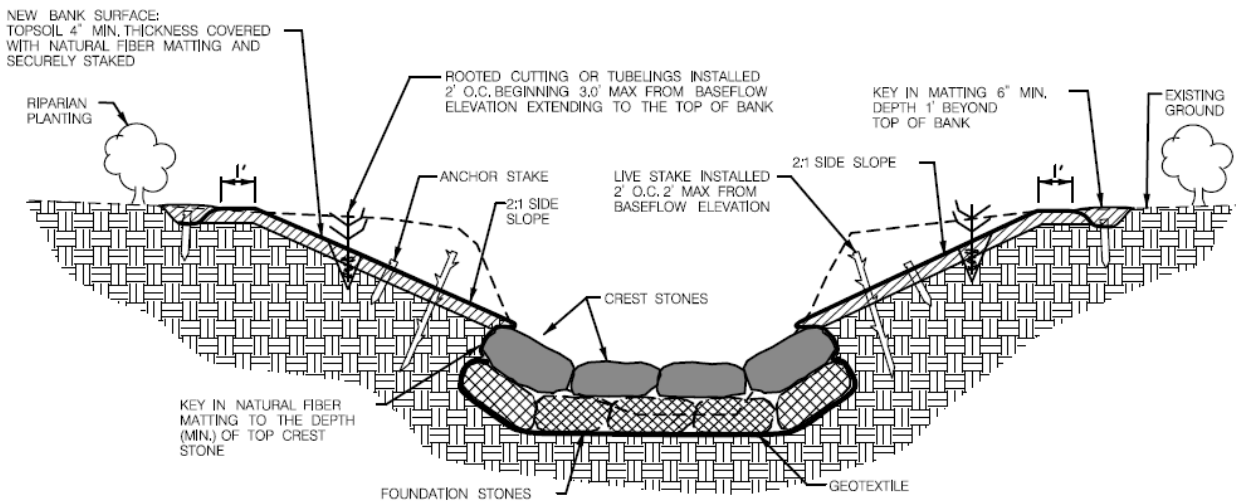
NOT TO SCALE

# Stream Restoration: Step Pool Structure



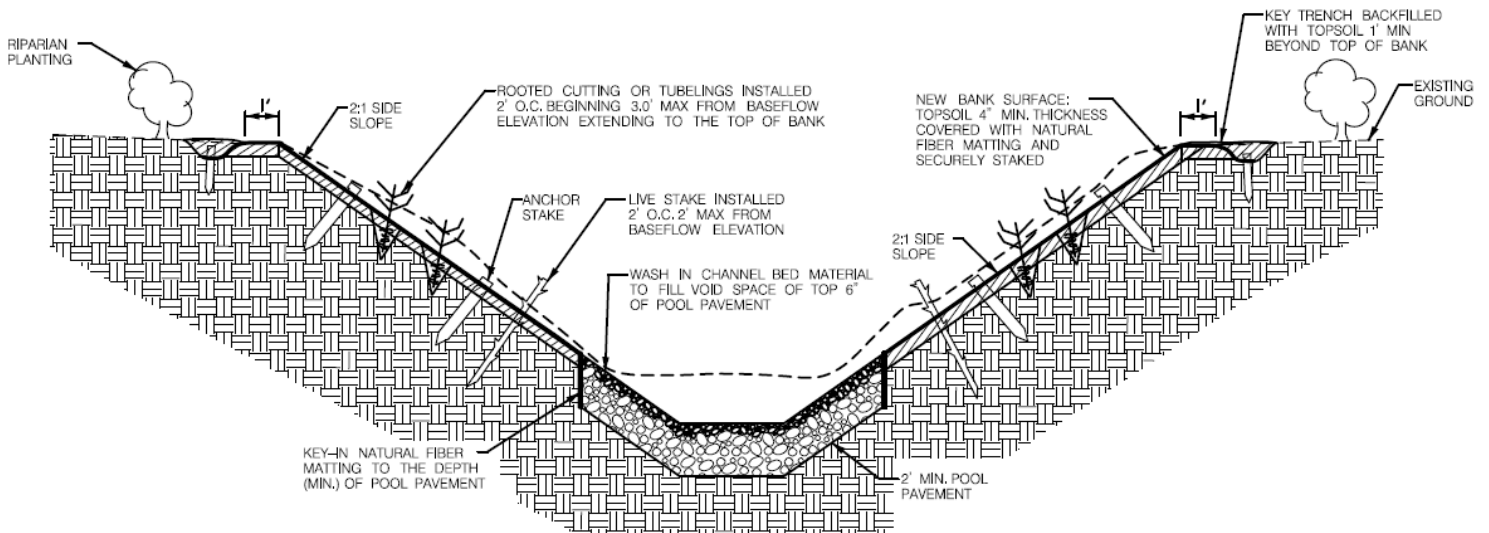
TYPICAL PROFILE THROUGH STEP-POOL

NOT TO SCALE



TYPICAL CROSS SECTION OF STEP-POOL CREST

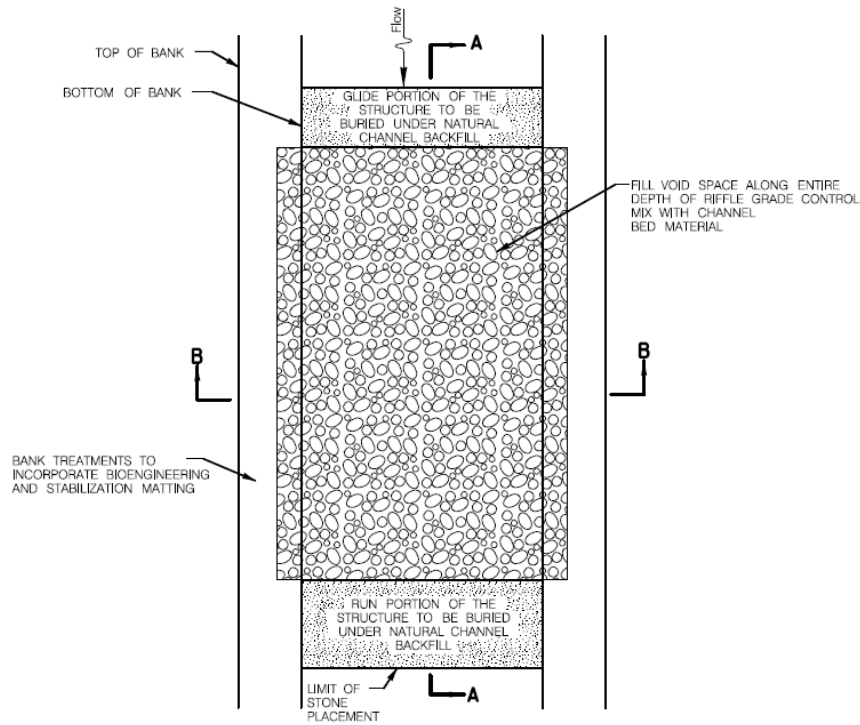
NOT TO SCALE



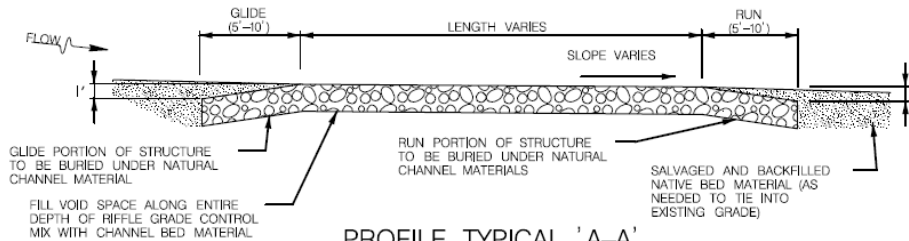
TYPICAL CROSS SECTION OF STEP-POOL POOL

NOT TO SCALE

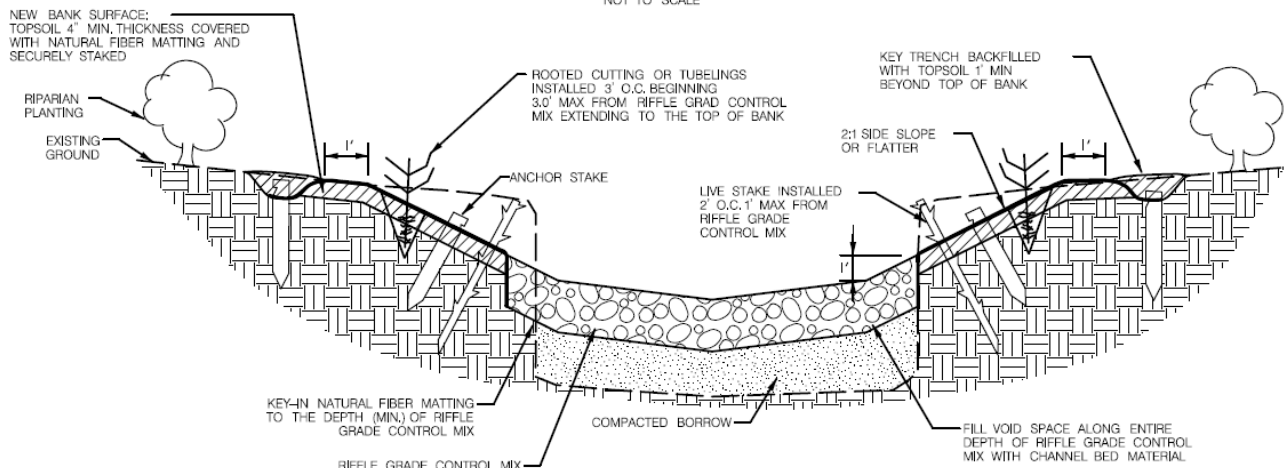
# Stream Restoration: Riffle Grade Control



**PLAN VIEW TYPICAL**  
**RIFFLE GRADE CONTROL**  
NOT TO SCALE

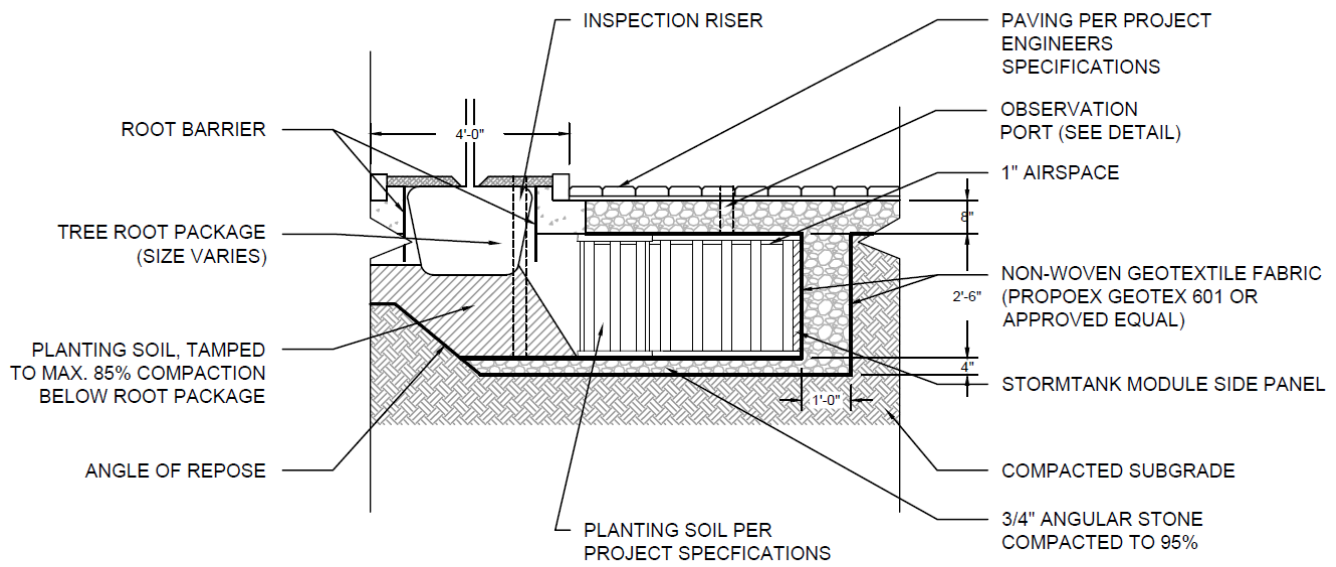


**PROFILE TYPICAL 'A-A'**  
**RIFFLE GRADE CONTROL**  
NOT TO SCALE

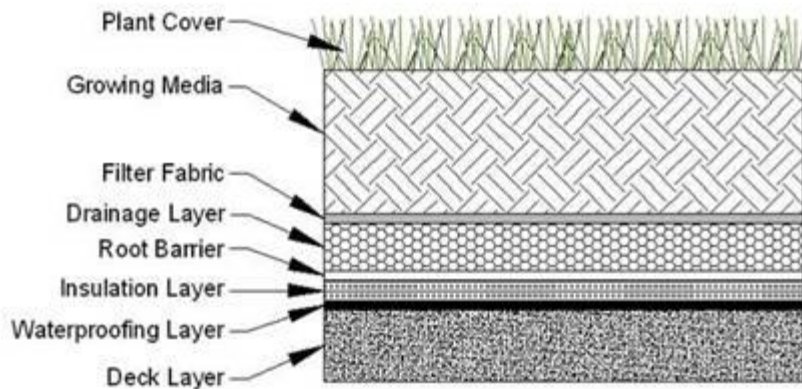


**CROSS SECTION TYPICAL 'B-B'**  
**RIFFLE GRADE CONTROL**  
NOT TO SCALE

# LID Treatments: Boulevard Approach and Green Roof Systems

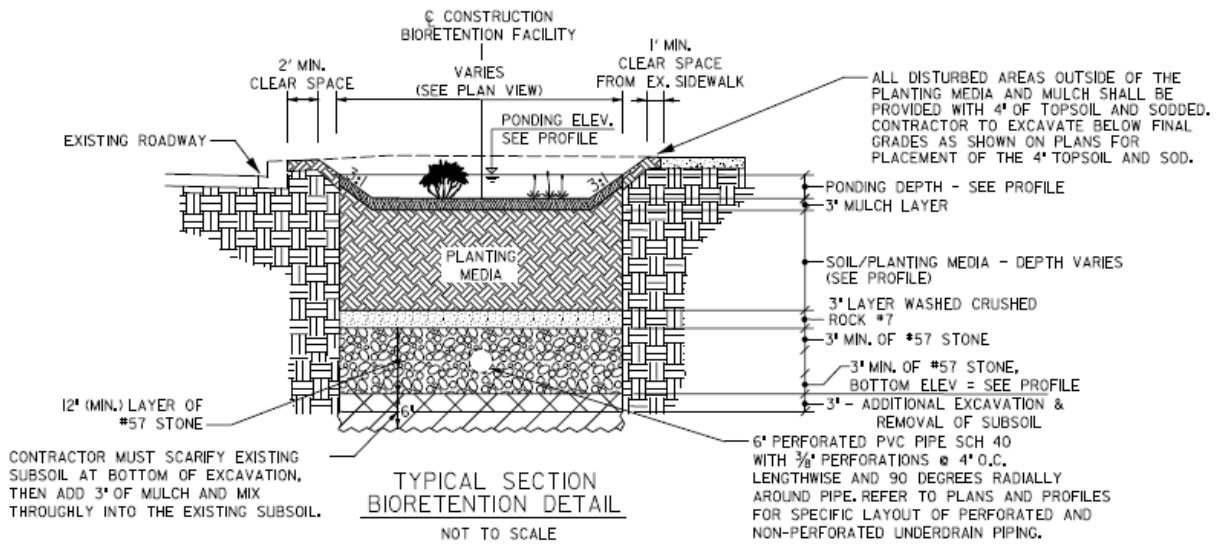
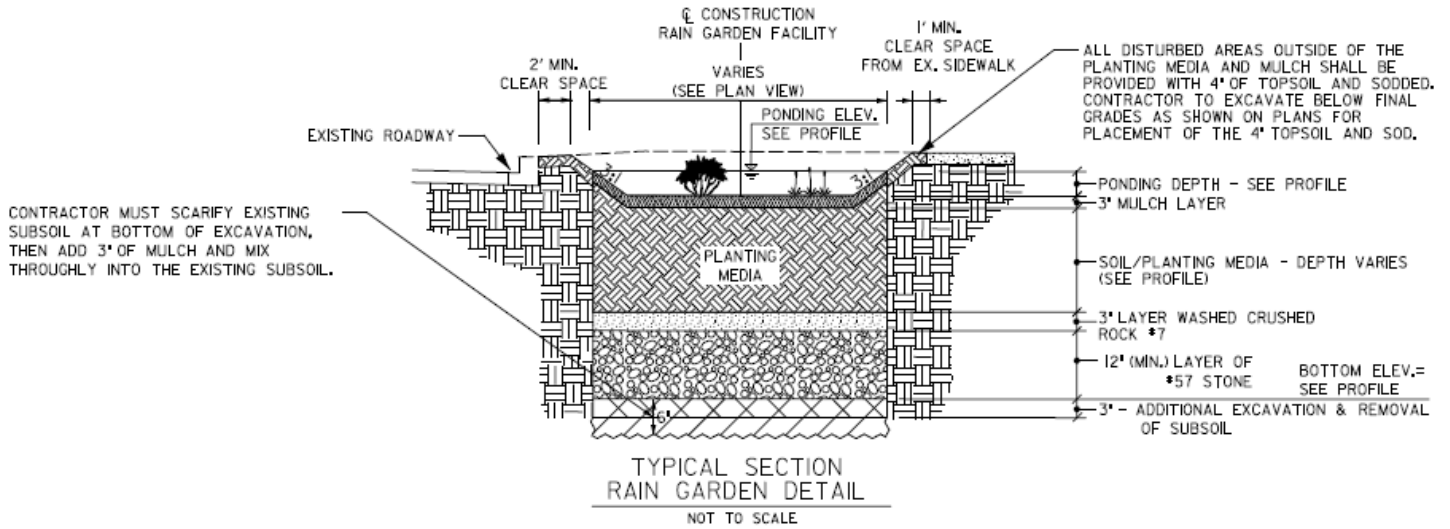


Boulevard Approach  
Tree Boxes

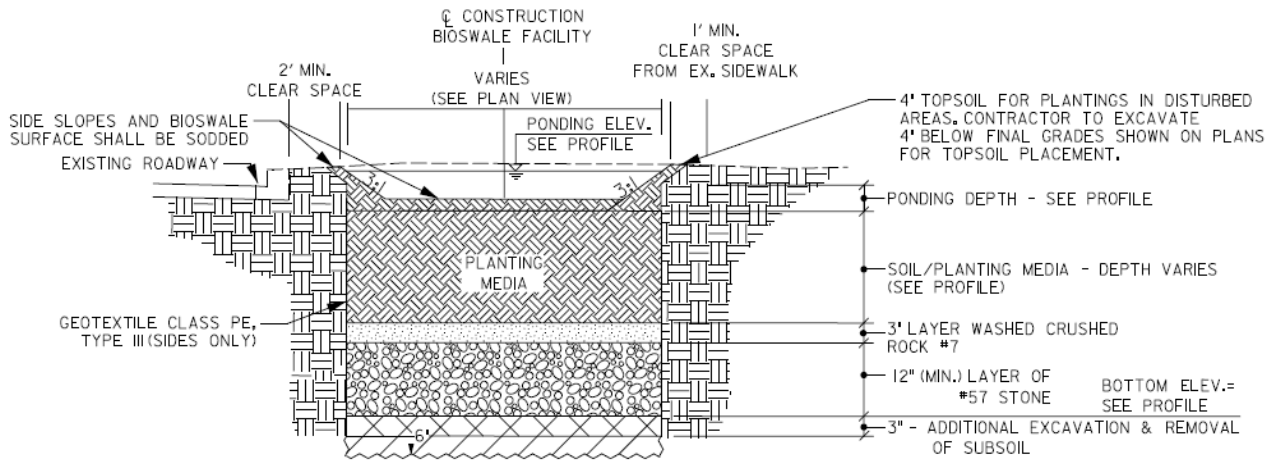


Green Roof System

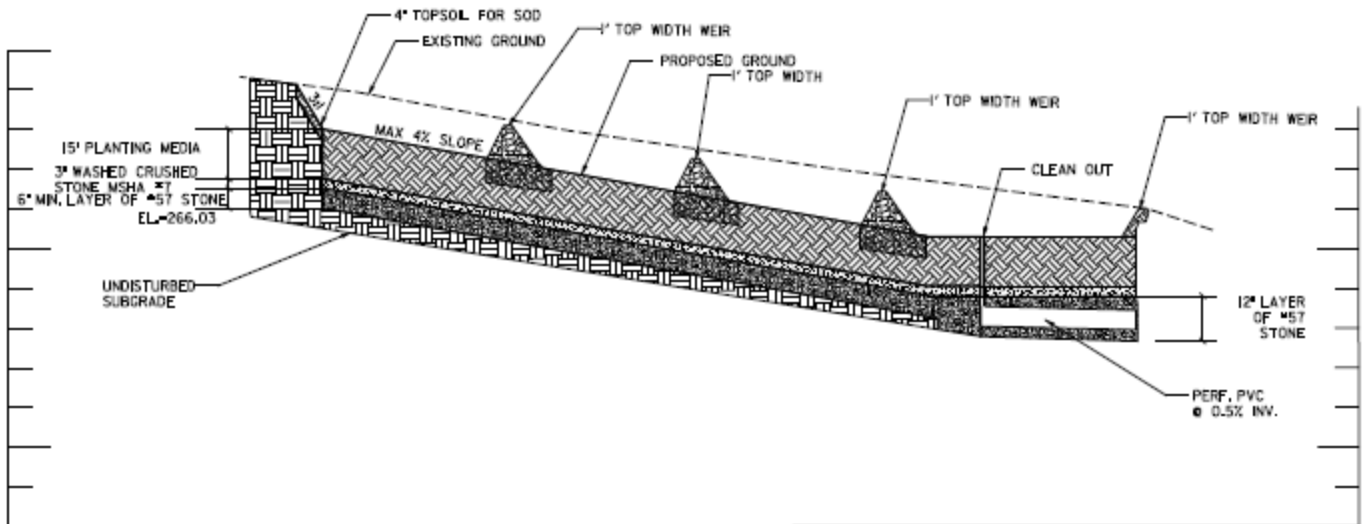
# LID Treatments: Rain Gardens and Bioretention Areas,



# LID Treatments: Bioswales

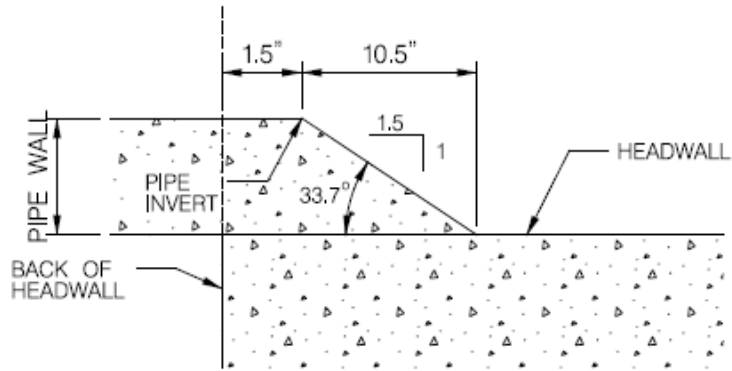


TYPICAL SECTION  
BIOSWALE DETAIL  
NOT TO SCALE



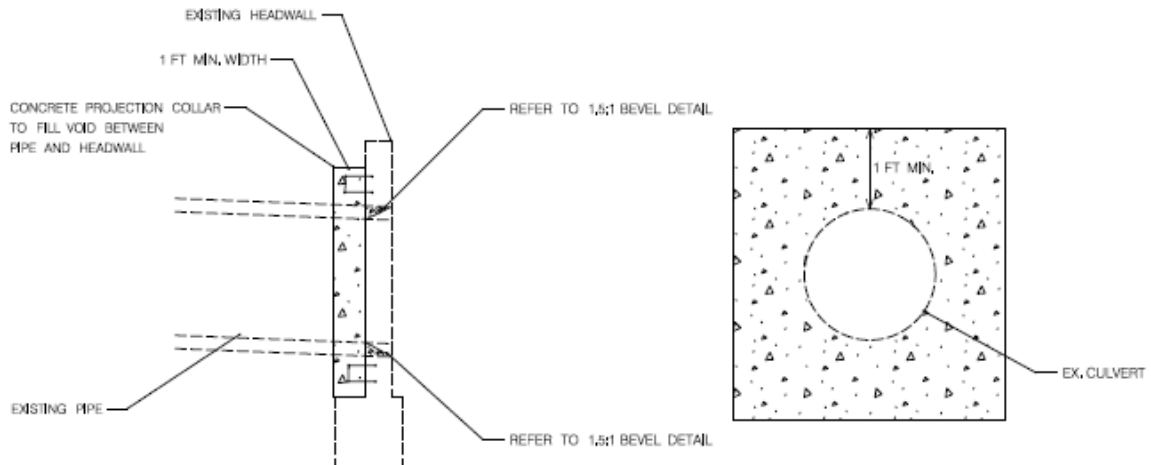
PROFILE A-A - BIOSWALE FACILITY (BMP44)

# LID Treatments: Beveled Edge Repair



## 1.5:1 INLET BEVEL

CONSTRUCT A 1.5:1 BEVEL AROUND ENTIRE CIRCUMFERENCE OF THE CULVERT.

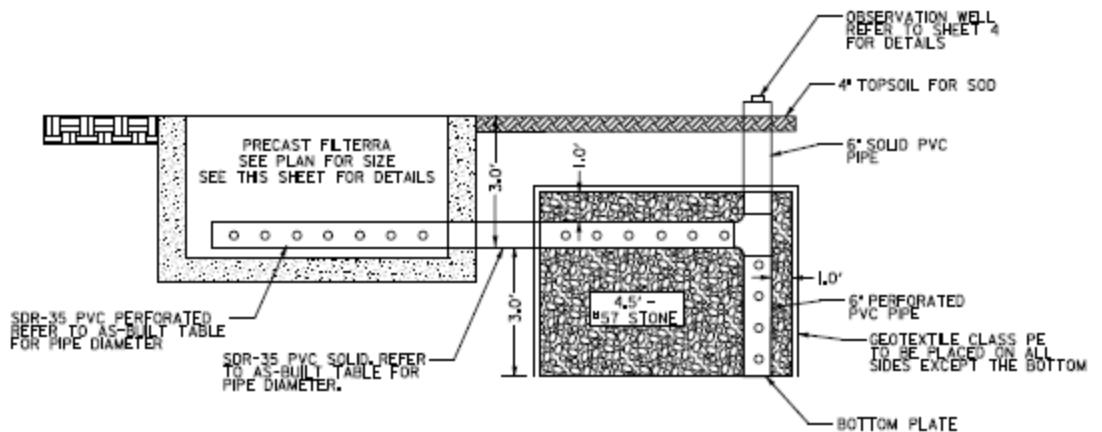
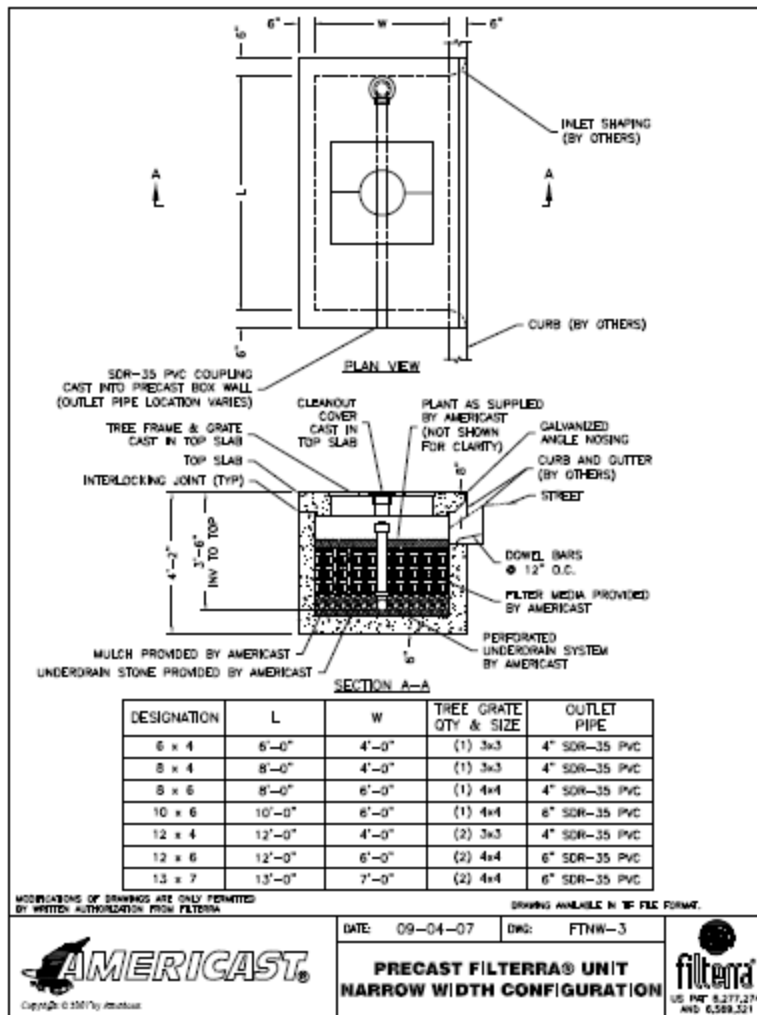


CAST 1 FOOT THICK CONCRETE COLLAR TO HEADWALL WITH 4 U=SHAPED REBARS

## CONCRETE PIPE COLLAR

NOT TO SCALE

# LID Treatments: Infiltration



TYPICAL FILTERRA AND STONE TRENCH DETAIL

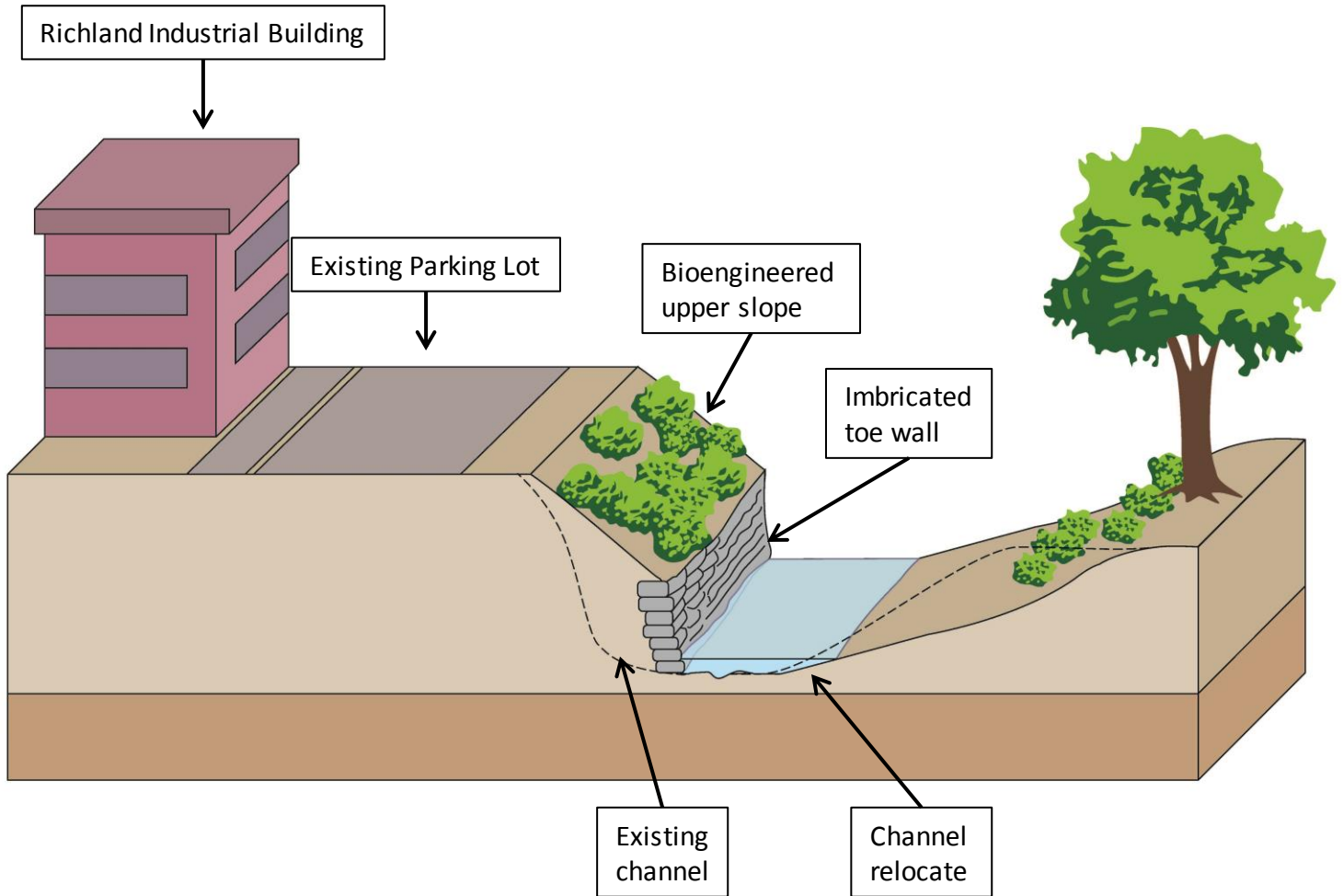
NOT TO SCALE

---



# Appendix D2: Project Concepts

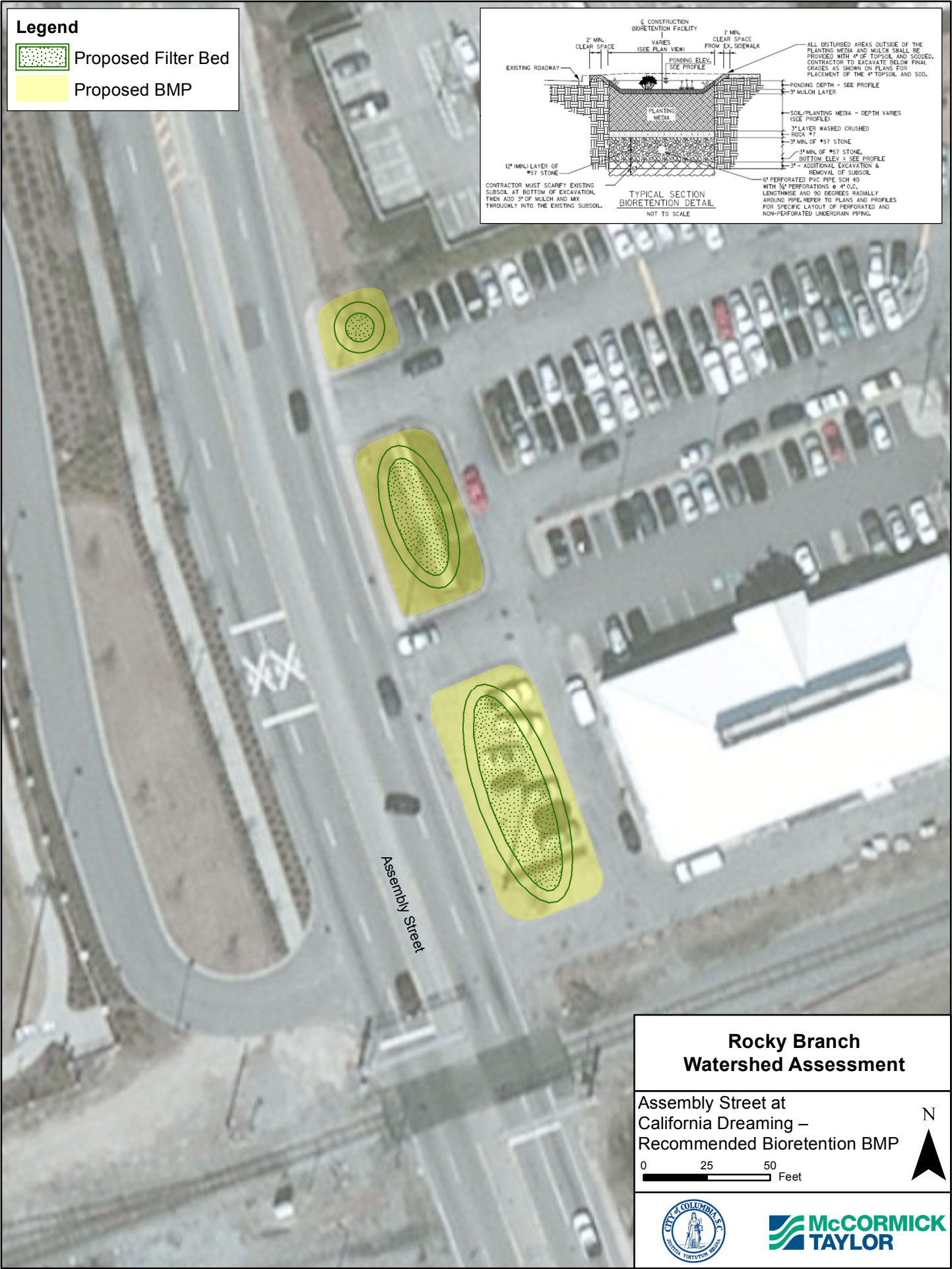
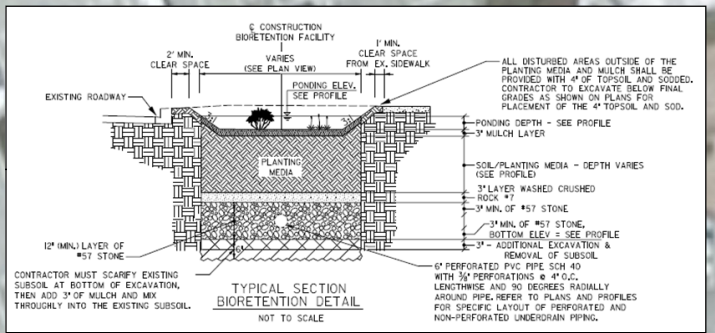
---

# Stream Restoration Concept: Tributary Between Catawba Street and Railroad by Richland Industrial



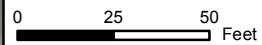
**Legend**

-  Proposed Filter Bed
-  Proposed BMP



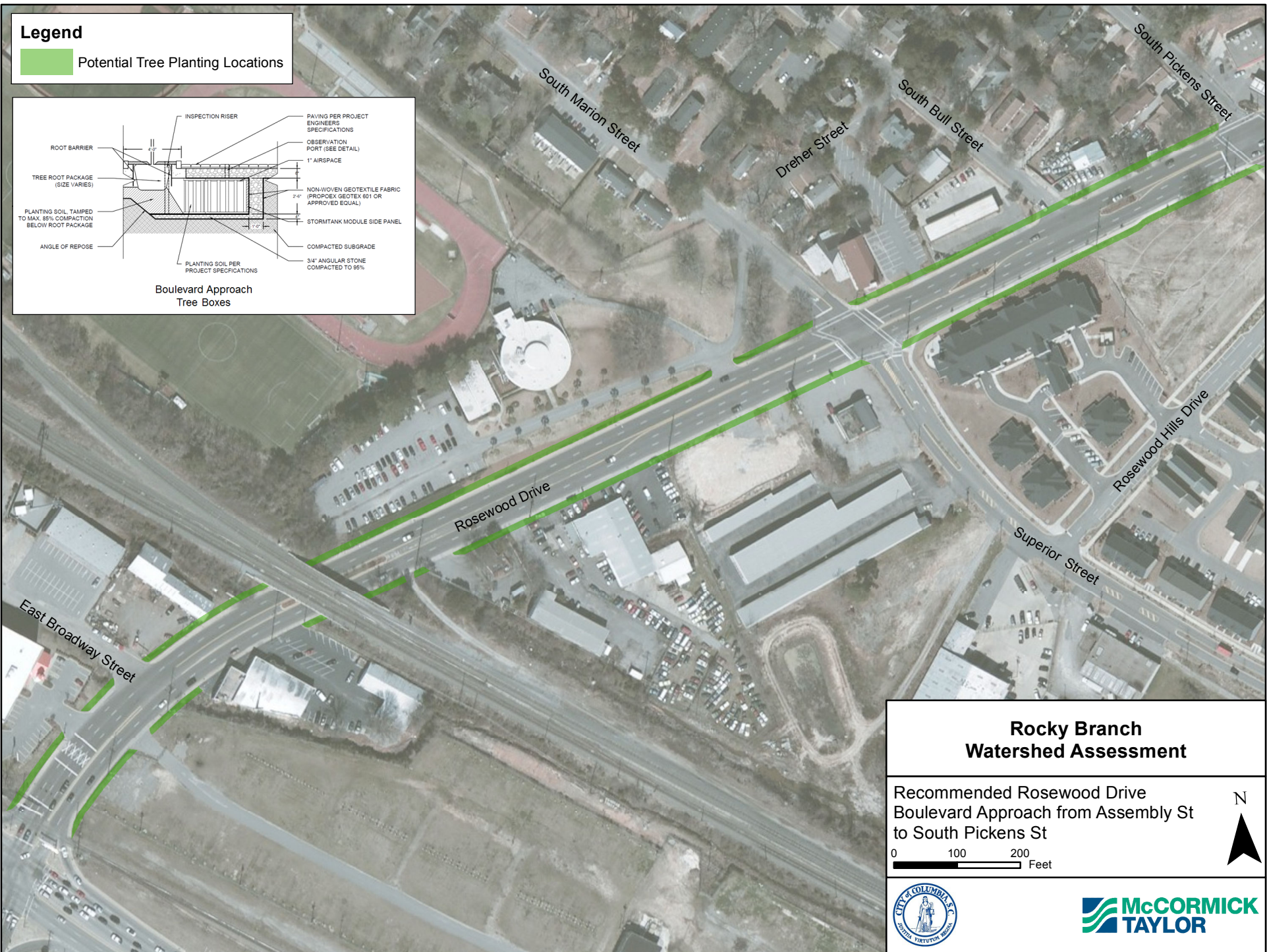
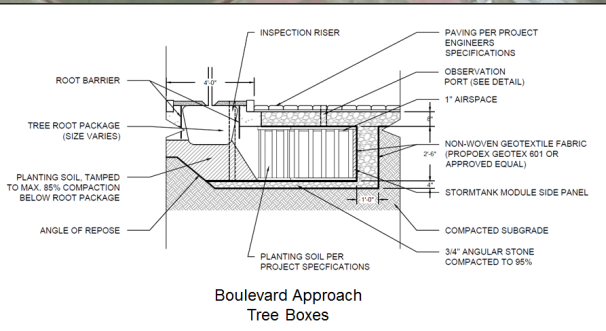
**Rocky Branch Watershed Assessment**

Assembly Street at California Dreaming – Recommended Bioretention BMP



# Legend

 Potential Tree Planting Locations



## Rocky Branch Watershed Assessment

Recommended Rosewood Drive Boulevard Approach from Assembly St to South Pickens St

