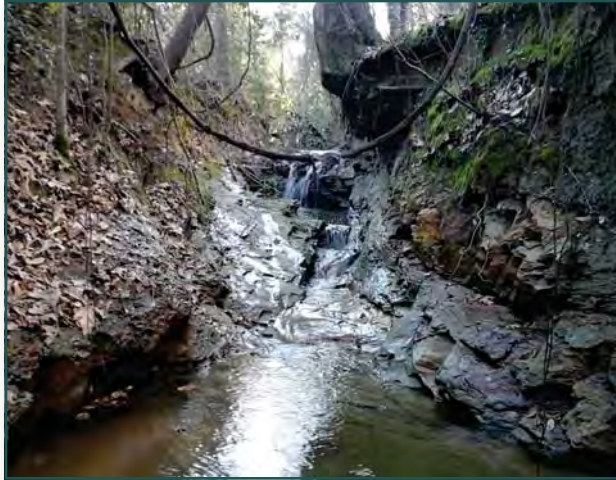


# SMITH BRANCH WATERSHED ASSESSMENT

Michael J.  
Jaspers  
2016.05.20  
15:47:10 -04'00'



MAY 20, 2016

PREPARED FOR:



CITY OF COLUMBIA  
UTILITY AND ENGINEERING DEPARTMENT  
1136 WASHINGTON STREET, 7TH FLOOR  
COLUMBIA, SOUTH CAROLINA 29201

PREPARED BY:



1441 MAIN STREET  
SUITE 875  
COLUMBIA, SOUTH CAROLINA 29201  
(410) 662-7400

IN ASSOCIATION WITH:



4000 FABRE PLACE DRIVE  
SUITE 300  
NORTH CHARLESTON,  
SOUTH CAROLINA 29405



## Table of Contents

1.0	Introduction.....	6
2.0	Study Objectives .....	6
3.0	Watershed Background.....	6
3.1	History.....	7
3.2	Geology.....	7
3.3	Ecoregion .....	9
3.4	Soils.....	9
3.5	Biological Data .....	11
4.0	Detailed Watershed Assessment .....	12
4.1	Stream Cruising Effort.....	12
4.2	Watershed Characterization .....	14
4.2.1	Subwatershed Breakouts.....	16
4.3	Hydrologic and Hydraulic (H&H) Analysis.....	16
4.3.1	Previous Studies.....	16
4.3.1.1	1994 FIS.....	16
4.3.1.2	2010 FIS.....	17
4.3.1.3	2015 Conditional FIS.....	17
4.3.1.4	GIS Layers .....	19
4.3.2	Model Development.....	19
4.3.3	Gage Results in HEC-RAS .....	23
4.3.4	Water Surface Profile Evaluation .....	24
4.3.5	Flow Results.....	25
4.3.6	Results from Culvert Analysis.....	29
4.3.7	Model Conclusions/Recommendations .....	31
4.3.8	Water Quality Data .....	31
5.0	Subwatershed Ranking.....	34
6.0	Detailed Subwatershed Assessment Results.....	36
6.1	Subwatershed H (SW-H) .....	39
6.2	Subwatershed F (SW-F).....	45
6.3	Subwatershed I (SW-I) .....	52
6.4	Subwatershed B (SW-B).....	61
6.5	Subwatershed G (SW-G) .....	68



6.6 Subwatershed D (SW-D) ..... 76

6.7 Subwatershed E (SW-E) ..... 85

6.8 Subwatershed J (SW-J) ..... 93

6.9 Subwatershed C (SW-C) ..... 102

6.10 Subwatershed A (SW-A) ..... 110

6.11 Subwatershed K (SW-K) ..... 118

6.12 Subwatershed L (SW-L) ..... 126

6.13 Subwatershed M (SW-M) ..... 134

7.0 Restoration Strategies ..... 142

7.1 Municipal and Institutional Strategies ..... 142

7.1.1 Stormwater Retrofits ..... 143

7.1.1.1 Low Impact Design ..... 144

7.1.1.1.1 Impervious Cover Removal ..... 144

7.1.1.1.2 Bioretention and Rain Gardens ..... 144

7.1.1.1.3 Green Roofs ..... 145

7.1.1.1.4 Green Streets ..... 145

7.1.1.1.5 Boulevard Approach ..... 145

7.1.1.1.6 Rain Harvesting (Cisterns) ..... 146

7.1.1.2 Stormwater Management Facilities ..... 146

7.1.1.3 Stream Restoration ..... 146

7.1.1.4 Reforestation/Buffer Establishment ..... 147

7.1.1.5 Infrastructure Improvement ..... 147

7.1.2 Enhanced Stormwater Management Requirements ..... 148

7.1.3 Stormwater Education and Outreach ..... 148

7.1.4 Tree Planting Incentives Programs ..... 149

7.2 Citizen-Based Strategies ..... 149

7.2.1 Downspout Disconnection ..... 149

7.2.2 Residential Nutrient Management and Lawn Maintenance ..... 150

7.3 Evaluation of Restoration Opportunities ..... 150

8.0 Watershed Project Identification and Prioritization ..... 152

9.0 Conclusions and Limitations ..... 163

References ..... 166



## List of Figures

Figure 3.1 Project Location.....	8
Figure 4.1 Watershed Assessment Methodology.....	12
Figure 4.2 Subwatersheds .....	13
Figure 4.3 GIS Storm Drains, Nodes, and Links .....	20
Figure 4.4 SWMM Model Layout .....	21
Figure 4.5 Smith Branch Gage A (Main St) .....	22
Figure 4.6 Smith Branch Gage B (Clement Rd.) .....	22
Figure 4.7 USGS Flow (Clement Rd.).....	23
Figure 4.8 September 25, 2015 Storm at Smith Branch A (Main St.).....	24
Figure 4.9 September 25, 2015 Storm at Smith Branch B (Clement Rd.).....	24
Figure 4.10 HEC-RAS RS Locations and 10-Year Results.....	26
Figure 4.11 Fecal Coliform Load Duration Curve 1990-2000, Station B-280 (Smith Branch) ...	32
Figure 4.12 Fecal Coliform Load Duration Curve 1994-2002, Station B-337 (Broad River).....	33
Figure 5.1 Subwatershed Ranking .....	35
Figure 6.1 Subwatershed Land Use .....	37
Figure 6.2 Subwatershed H.....	39
Figure 6.3 SW-H Soils.....	40
Figure 6.4 SW-H Existing Conditions.....	41
Figure 6.5 SW-H SWMM Model .....	43
Figure 6.6 SW-H Restoration Opportunities .....	44
Figure 6.7 Subwatershed F .....	45
Figure 6.8 SW-F Soils.....	46
Figure 6.9 SW-F Existing Conditions.....	47
Figure 6.10 SW-F SWMM Model.....	49
Figure 6.11 SW-F Restoration Opportunities .....	51
Figure 6.12 Subwatershed I .....	52
Figure 6.13 SW-I Soils .....	53
Figure 6.14 SW-I Existing Conditions.....	54
Figure 6.15 SW-I SWMM Model.....	58
Figure 6.16 SW-I Restoration Opportunities .....	60
Figure 6.17 Subwatershed B .....	61
Figure 6.18 SW-B Soils .....	62
Figure 6.19 SW-B Existing Conditions .....	63
Figure 6.20 SW-B SWMM Model.....	66
Figure 6.21 SW-B Restoration Opportunities.....	67
Figure 6.22 Subwatershed G.....	68
Figure 6.23 SW-G Soils.....	69
Figure 6.24 SW-G Existing Conditions.....	70
Figure 6.25 SW-G SWMM Model .....	73
Figure 6.26 SW-G Restoration Opportunities .....	75
Figure 6.27 Subwatershed D.....	76
Figure 6.28 SW-D Soils.....	77
Figure 6.29 SW-D Existing Conditions .....	78
Figure 6.30 SW-D SWMM Model .....	82
Figure 6.31 SW-D Restoration Opportunities .....	84



Figure 6.32 Subwatershed E ..... 85

Figure 6.33 SW-E Soils ..... 86

Figure 6.34 SW-E Existing Conditions ..... 87

Figure 6.35 SW-E SWMM Model..... 90

Figure 6.36 SW-E Restoration Opportunities ..... 92

Figure 6.37 Subwatershed J ..... 93

Figure 6.38 SW-J Soils ..... 94

Figure 6.39 SW-J Existing Conditions ..... 95

Figure 6.40 SW-J SWMM Model..... 99

Figure 6.41 SW-J Restoration Opportunities..... 101

Figure 6.42 Subwatershed C ..... 102

Figure 6.43 SW-C Soils ..... 103

Figure 6.44 SW-C Existing Conditions ..... 104

Figure 6.45 SW-C SWMM Model..... 107

Figure 6.46 SW-C Restoration Opportunities..... 109

Figure 6.47 Subwatershed A ..... 110

Figure 6.48 SW-A Soils ..... 111

Figure 6.50 SW-A SWMM Model ..... 115

Figure 6.51 SW-A Restoration Opportunities ..... 117

Figure 6.52 Subwatershed K ..... 118

Figure 6.53 SW-K Soils ..... 119

Figure 6.54 SW-K Existing Conditions ..... 120

Figure 6.55 SW-K SWMM Model ..... 124

Figure 6.56 SW-K Restoration Opportunities ..... 125

Figure 6.57 Subwatershed L ..... 126

Figure 6.58 SW-L Soils ..... 127

Figure 6.59 SW-L Existing Conditions ..... 128

Figure 6.60 SW-L SWMM Model..... 132

Figure 6.61 SW-L Restoration Opportunities ..... 133

Figure 6.62 Subwatershed M ..... 134

Figure 6.63 SW-M Soils ..... 135

Figure 6.64 SW-M Existing Conditions ..... 136

Figure 6.65 SW-M SWMM Model..... 139

Figure 6.66 SW-M Restoration Opportunities..... 141

Figure 7.1 Example City of Columbia Educational Program: My River Starts Here..... 149

Figure 8.1 Individual Restoration Project Identification ..... 153

**List of Tables**

Table 3.2 Smith Branch Watershed Soil Descriptions..... 10

Table 4.1 Data Collected During the Stream Cruising Effort..... 15

Table 4.2 2010 FIS Discharges ..... 17

Table 4.3 2015 Conditional FIS Discharges ..... 18

Table 4.4 2015 Conditional FIS Existing HEC-RAS Flows..... 25

Table 4.5 Updated HEC-RAS Flows from 2016 SWMM ..... 27

Table 4.6 USGS Calculated Peak Flows compared to 2016 SWMM Peaks for Smith Branch ... 27

Table 4.7 Comparison of Estimated Colonial Drive Flows ..... 27



---

Table 4.8 Bay Branch Drainage Areas and Flows from 2015 Conditional FIS .....	28
Table 4.9 Bay Branch Drainage Areas and Flows from 2016 SWMM Model.....	28
Table 4.10 Culvert Analysis Scenario 1: Colonial Drive to Clement Street Culvert Replacement .....	29
Table 4.11 Culvert Analysis Scenario 2: Sunset Drive Culvert Upgrade.....	30
Table 5.1 Subwatershed Runoff Rankings (2-year Storm Event).....	34
Table 6.1 Subwatershed Land Use.....	38
Table 8.1 Individual Project Identification and Description.....	154
Table 8.2 Subwatershed Water Quality Volume .....	161

## Appendices

- Appendix A: Historic Aerial Photos
- Appendix B: Field Data Dictionary (Stream Cruising Effort)
- Appendix C: Water Quality Data
- Appendix D: Design Solutions



## 1.0 Introduction

McCormick Taylor Inc., supported by KCI Technologies, Inc., has been contracted by the City of Columbia, South Carolina to conduct an assessment of the Smith Branch watershed to identify potential improvement opportunities to identify existing flooding and water quality conditions.

This report extensively documents the existing conditions for the Smith Branch Watershed and describes the methodology and results of a study to identify and prioritize restoration opportunities. The watershed was evaluated based on ecologic, hydrologic and hydraulic functions to characterize existing conditions and highlight potential restoration opportunities.

## 2.0 Study Objectives

There are a number of objectives sought from the development of this report. Determining the existing conditions of the watershed as a baseline for the assessment was of foremost importance. Understanding the existing conditions allowed the team to evaluate the predominant needs of the watershed by assessing, in detail, the physical characteristics that contribute to its overall condition.

Once the team characterized the condition of the watershed, further assessment of the need and location for potential restoration initiatives was undertaken. This was completed through a series of detailed evaluations which assessed the restoration need and potential across the watershed, specifically focusing on improving water quality and reducing flood risk.

The assessments of existing conditions and restoration potential were then collectively reviewed to arrive at the ultimate objective of identifying Watershed Projects in areas of greatest need within the watershed. These projects are focused on achieving the observed needs of the watershed and may be undertaken by various organizations (government entities, businesses, non-profit organizations, etc.).

## 3.0 Watershed Background

The Smith Branch Watershed is located primarily within the City of Columbia, SC (**Figure 3.1**). The watershed is over seven square miles in drainage area and includes 15.7 miles of open stream channel which drain to the Broad River. The watershed is home to the Palmetto Health Richland Campus, DHEC, portions of the Benedict College Campus, Lutheran Theological Southern Seminary, William L. Bonner College, Burton-Pack Elementary School, WA Perry Middle School, Watkins-Nance Elementary School, C.A. Johnson High School, Earlewood Park, TS Miller Park, Hyatt Park, and Lincoln Park. The dominant land uses within the Smith Branch Watershed, as of 2011, include developed land of medium and low density and developed open space. Total imperviousness within the Smith Branch Watershed is 37%. The high imperviousness of the watershed combined with minimal stormwater controls and under-sized conveyances create flooding conditions on a frequent basis. The Center for Watershed Protection (CWP) studied the effects of imperviousness on channel and watershed conditions; the high imperviousness of the Smith Branch Watershed classifies it in the mid-range of the non-supporting streams category. Non-supporting streams no longer support their designated uses (biological indicators, channel stability, habitat, hydrology and water quality) and primary restoration goals should be to improve the stream corridor, reduce pollutants, or enhance community aesthetics (Schueler, 2005).



### 3.1 History

The Smith Branch subwatershed is mainly within the City of Columbia, SC. Columbia was first settled as a frontier fort in the mid 1700's. In 1786, Columbia was designated as the state capital of South Carolina. Columbia was later chartered as a town in 1805, with a population of over 1,000. Initially the city was two square miles that ran along the eastern bank of the Congaree River. Suburbs began to form in 1870 as the population grew. The streets were first paved with asphalt in 1925 (City of Columbia, 2016).

Historical aerial photographs were analyzed for the following years: 1938, 1959, 1970, 1981, 1994, 2006, and each year between 2010 and 2015 to assess changes in land cover. The downstream end of Smith Branch consisted primarily of farmland in 1938; the aerial photography from 1959 shows expansion of the suburbs and reforestation of some of the open areas. Aerial photography from the northern end of the watershed is lacking, but nearby land cover suggests a trend towards suburbanization following 1959 (**Appendix A**).

The upstream portion of the mainstem of Smith Branch resides within the former campus of the South Carolina Lunatic Asylum, originally built in 1828. Flooding of the ground floors was noted from early in the building's history (Craft, 1994). Expansion of the buildings can be seen between 1938 and 1959 with the channel flowing through clear cut regions within the campus. By 1970, sections of the channel are no longer visible, having been rerouted through underground pipes. The aerial from 1981 shows some reforestation around segments of open channel.

### 3.2 Geology

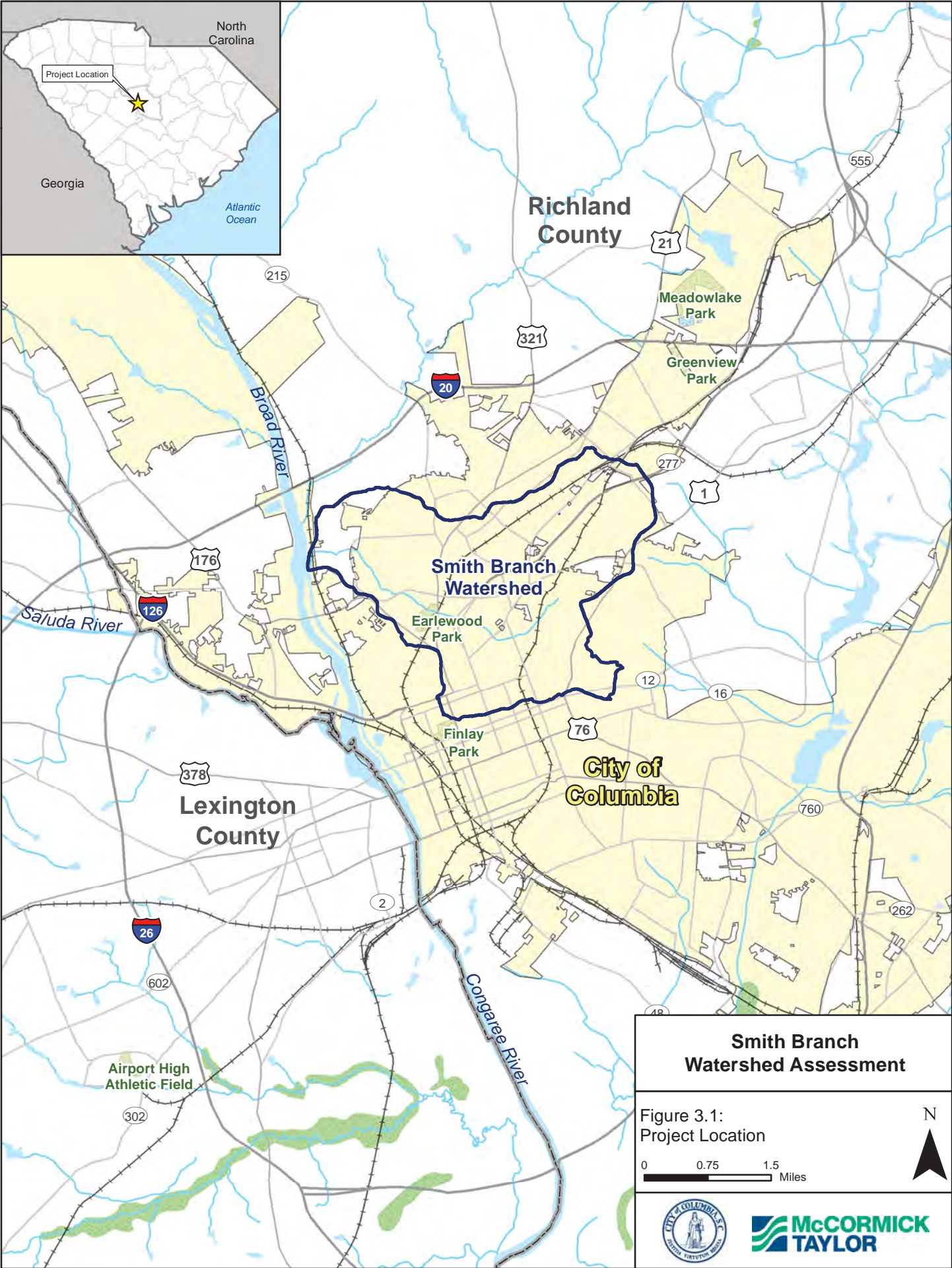
The Smith Branch Watershed is located where the Coastal Plain adjoins the Piedmont province (known as the Fall Line), as shown in **Figure 3.2**. The majority of the watershed exists within the Congaree Sand Hills, which corresponds approximately to the Cape Fear formation of the Upper Cretaceous (Kcfe). The Cape Fear formation consists primarily of light-colored cross-bedded arkosic sand, gravel deposited in delta-dominated fluvial and restricted environments, and lenses of massive light-colored clay and kaolin with many local unconformities (United States Department of Agriculture Soil Conservation Service, 1978).

**Figure 3.2 Physiographic Provinces of SC**



The northwest portion of the watershed lies within the Carolina Terrane (ct) of the Piedmont. More specifically, the Piedmont portion of the watershed is located mostly within the Modoc Fault Zone characterized by mylonitic rocks formed in the late Paleozoic. A smaller portion of this area is located within the Columbia pluton characterized by granite and granitic gneiss that are Carboniferous to Permian in age.

The dominant formations in the watershed are composed of unconsolidated and soft or soluble deposits that are more easily eroded than the granites, gneisses, and schists below them. Channel incision can be rapid



**Smith Branch  
Watershed Assessment**

Figure 3.1:  
Project Location

0 0.75 1.5  
Miles





when progressing through the more erodible deposits and rates of erosion slow as incision and widening reach the resistant rocks beneath the softer materials.

### 3.3 Ecoregion

Smith Branch lies mostly in the Sandhills ecoregion, though a portion of the northern part of the watershed is within the Carolina Slate Belt ecoregion. The Sandhills ecoregion consists of rolling hills made of cretaceous-age marine sand and clays that are drought-prone and low in nutrients. The Carolina Slate Belt ecoregion is mineral-rich with metavolcanic and metasedimentary rocks with silty or silty clay soils (Griffith, 2002).

Sandhills ecoregion streams typically have a loose sandy bed with indistinct features. The transition from the Piedmont to the Sandhills is evidenced by the broad floodplain landscape of the Congaree River below the confluence of the Broad and Saluda. The channel bed and banks of the Smith Branch mainstem and tributaries are so extensively altered that they no longer resemble the natural form of a Sandhills stream.

Native riparian habitat within the Sandhills ecoregion consists of longleaf pine stands, hardwood forests, or pocosin-like evergreen shrubs. Small isolated wetlands are key features in the riparian area, providing breeding grounds for the herpetofauna of the region. Longleaf pine forests require frequent fire events to provide bare mineral soil for their seeds to germinate and to limit the establishment of other hardwood tree species. When suitable fire conditions aren't present, hardwood tree species will establish in the narrow floodplain in the low lying areas between the sandhills (SCDNR, 2005). Development of the Smith Branch watershed has resulted in fragmentation to complete removal of riparian habitat.

The Carolina Slate Belt ecoregion typically has low to moderate grade streams with a bed consisting of mostly boulder and cobble. Riparian forests are a mix of oak, hickory and pine, with longleaf pine stands common. Tributaries tend to be ephemeral or intermittent because of the low water-yielding rock units within this region (Griffith, 2002). The northwestern section of the Smith Branch watershed falls within this ecoregion. Characteristics of the Carolina Slate Belt ecoregion were not observed because of the highly developed nature of this region.

### 3.4 Soils

Information on the soils in the study site was obtained from the Web Soil Survey developed by the US Department of Agriculture, National Resources Conservation Service (NRCS). Hydrologic soils are grouped from the most well-drained (type A) to the most poorly drained (type D). The predominant hydrologic soil group within the Smith Branch Watershed is type B, followed by type D, A, and C, respectively. Urban land accounts for over 39% of the soils classified as Group D. **Table 3.1** displays the percent of each hydrologic soil group within the Smith Branch Watershed.

**Table 3.1 Smith Branch Watershed Hydrologic Soils Group Distribution**

Hydrologic Soil Group	% Smith Branch Watershed
A	3%
B	53%
C	1%
D	43%



Mapping of the soils within each subwatershed is found in **Section 6.0. Table 3.2** lists the drainage class and parent material for the most commonly found soils within the watershed.

**Table 3.2 Smith Branch Watershed Soil Descriptions**

Soil	Soil Description	Drainage Class	Parent Material
Cd	Chastain silty clay loam	Poorly drained	Fine-textured clayey alluvium
DuB	Dothan-Urban complex	Well drained	Unconsolidated, medium to fine marine sediments
FyB	Fuquay-Urban complex	Well drained	Sandy over loamy marine or fluviomarine deposits
GeC	Georgeville silt loam	Well drained	Meta-volcanic rock from the Carolina Slate Belt
Jo	Johnston loam	Very poorly drained	Alluvium
LaD	Lakeland sand	Excessively drained	Eolian sands
LkB	Lakeland sand	Excessively drained	Eolian or fluviomarine sands
NaE	Nason complex	Well drained	Saprolite of schist and other metamorphic rocks
ObB	Orangeburg loamy sand	Well drained	Fluviomarine deposits
OgD	Orangeburg-Urban complex	Well drained	Loamy and clayey marine sediments
OgB	Orangeburg-Urban complex	Well drained	Fluviomarine deposits
PnC	Pelion-Urban complex	Moderately well drained	Fluviomarine deposits and sand sheets
Ra	Rains sandy loam	Poorly drained	Marine and fluviomarine deposits
Ud	Udorthents	Moderately well drained	Clayey or loamy residuum or alluvium
Ur	Urban Land	Poorly drained	Impervious surface and fill
VaC	Vaucluse loamy sand	Well drained	Fluviomarine deposits
VaD	Vaucluse loamy sand	Well drained	Fluviomarine or marine deposits
WeE	Wedowee loamy sand	Well drained	Residuum of metamorphic or igneous rock

The majority of the soils present in the study area are part of the Pelion-Urban, Urban Land, and Orangeburg-Urban land complexes. The Pelion series consists of deep, moderately well drained soils formed in loamy marine sediments of the Sand Hills of the Coastal Plain. Urban land (Ur) consists of areas covered by asphalt roadways or parking lots, concrete structures, buildings and other impervious surfaces which provide a flashy hydrologic response. Areas where more than 85% of the surface is covered by impervious structures are simply mapped as Urban land. The high imperviousness decreases infiltration and increases runoff. Other complexes in the watershed consist of relatively undisturbed (parent) soils with areas altered by cutting, filling, or



grading in such an intricate pattern that it is not practical to separate them, i.e. Orangeburg-Urban complex. Fill material in altered areas most commonly consists of adjacent soils that were cut or graded, however soil properties may vary. The Orangeburg series consists of deep, well drained soils formed on the tops and sides of broad ridges and interstream divides in the Coastal Plain. The prominence of soils with a very slow infiltration rate, along with the impervious surfaces of urban land, increases the potential for flash flooding.

The floodplains of Smith Branch are composed of Johnston loam (Jo), Chastain silty clay loam (Cd), and Rains sandy loam (Ra). All of these series are very poorly drained to poorly drained. The Jo series has a high water table most of the year (water covers the surface during wet seasons) and the series floods frequently and for long durations. Cd soil is commonly flooded for long periods throughout the year. A small portion of the Smith Branch floodplain is comprised of Ra soils where the water table is at a depth of less than 1 foot during most of the year and flooded for brief periods from December to March. Floodplain series soils were only present in areas where the floodplain was undeveloped and consisted of woodland; the urbanized nature of the watershed has limited connection to natural floodplain soils for much of Smith Branch.

### **3.5 Biological Data**

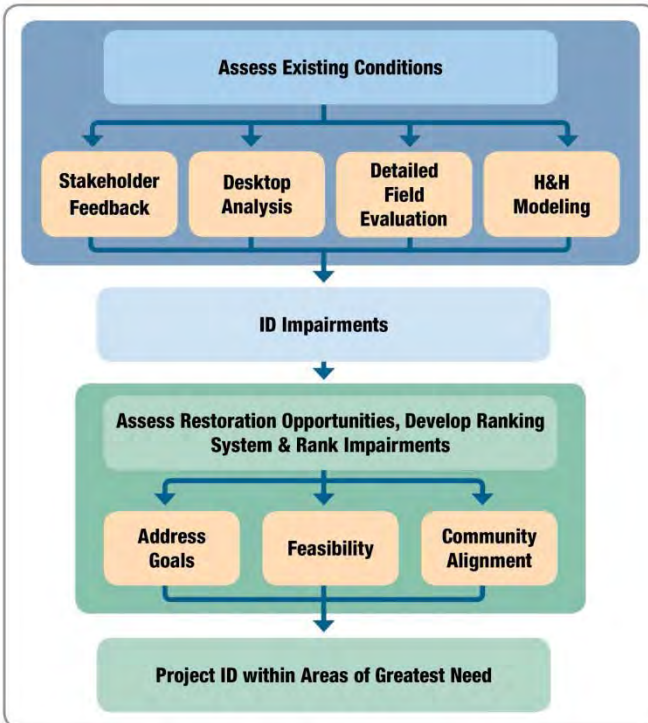
Biological data comes from DHEC and the South Carolina Department of Natural Resources (SCDNR). DEHC sampled for macroinvertebrates, water chemistry, and habitat at one site along Smith Branch three times over the course of 15 years (1995-2009). The bioclassification result was poor for the macroinvertebrates in all three sampling events. Habitat was scored using the EPA's Habitat Assessment form and a simplified habitat assessment form that is more specific for instream macroinvertebrate habitat developed by the Aquatic Biology Section of the DHEC. The overall habitat score decreased over the years.

SCDNR conducted a fish survey in October 2010. Only four species were captured: bluehead chub, fathead minnow, eastern mosquito fish, and redbreast sunfish. All are native species, with the exception of the fathead minnow. All four species prefer slow moving, pool habitats. Poor water quality and frequent channel alteration likely limit the establishment of a more diverse biological community.

## 4.0 Detailed Watershed Assessment

A multi-faceted methodology was implemented (**Figure 4.1**), first by assessing the existing conditions of the watershed through desktop analysis of existing information as described above.

**Figure 4.1 Watershed Assessment Methodology**



Following desktop analysis and development of a general existing conditions overview, field efforts were initiated. This included conducting a field cruising effort of all open channel streams to assess the general health of the system based on physical appearance. The goal was to determine the type of impairments existing in the system to better inform the evaluation process.



Following the initial assessment, the watershed was portioned into a series of thirteen subwatersheds, as shown in **Figure 4.2**. Subwatersheds were determined by geomorphic and hydrologic breaks observed in Geographic Information System (GIS) data and from the stream cruising effort. The subwatershed breakout is described further in **Section 4.2.1**.

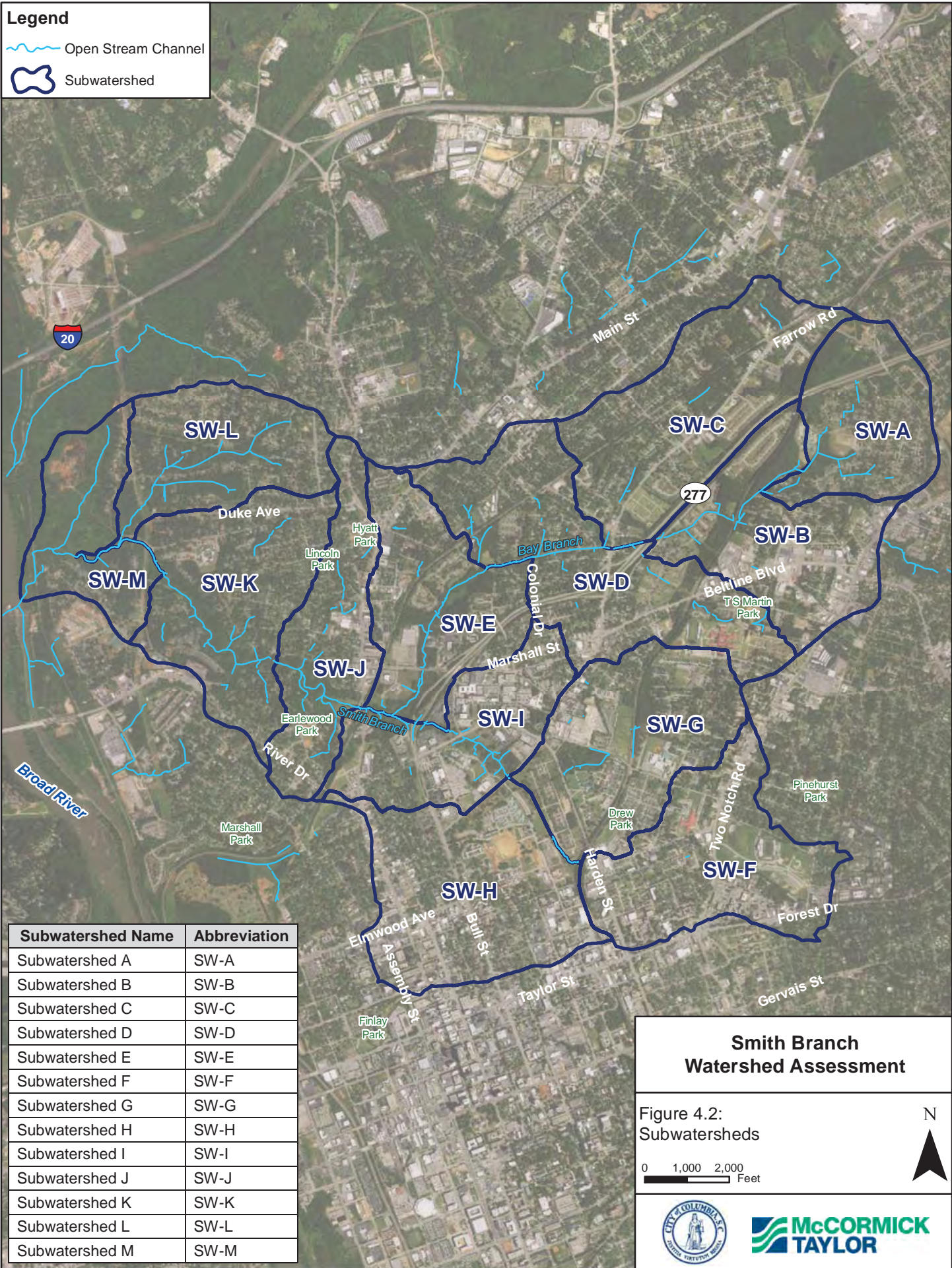
Once subwatershed breaks were established, several evaluations were conducted both in the field, through visual inspection, and using GIS data to further evaluate the individual subwatersheds. Following these evaluations, preliminary data review pointed to the high level of urbanization and associated flooding as the primary issues within the watershed. Considering the level of urbanization and complexity of the drainage network, the Storm Water Management Model (SWMM) was used to evaluate and eventually rank each subwatershed. Based on this ranking, Watershed Projects were identified in all subwatersheds with a focus in the subwatersheds with the greatest impairment. This methodology is summarized in **Figure 4.1** and described in detail below.

### 4.1 Stream Cruising Effort

The stream cruising effort, loosely based on the Maryland Stream Corridor Assessment (SCA) Survey Protocols (Yetman, 2001), was used to catalog and characterize existing conditions and impairments observed within the stream channel network. The SCA method was originally developed to provide a broad ecosystem based approach to evaluate and restore watersheds in Maryland. It is designed not just to provide information about the location, type, and severity of environmental problems, but inform managers of restoration opportunities within a watershed. Stream cruising efforts were used to rapidly assess the general physical health of the stream system and identify specific problem points.

**Legend**

-  Open Stream Channel
-  Subwatershed



Subwatershed Name	Abbreviation
Subwatershed A	SW-A
Subwatershed B	SW-B
Subwatershed C	SW-C
Subwatershed D	SW-D
Subwatershed E	SW-E
Subwatershed F	SW-F
Subwatershed G	SW-G
Subwatershed H	SW-H
Subwatershed I	SW-I
Subwatershed J	SW-J
Subwatershed K	SW-K
Subwatershed L	SW-L
Subwatershed M	SW-M

**Smith Branch  
Watershed Assessment**

Figure 4.2:  
Subwatersheds

0 1,000 2,000  
Feet





The stream cruising effort evaluated approximately 83,000 linear feet (15.7 miles) of channel within the Smith Branch Watershed. Data were collected during the field effort regarding the location, severity, correctability, and accessibility of problem points along the stream network. Environmental problems and conditions that were identified include: Bedrock, Channel Alterations, Erosion Sites, Exposed Pipes, In-stream Habitat, Inadequate Forest Buffers, Near Stream Construction, Pipe Outfalls, Possible Fish Barriers, Representative Photo Site, Trash Dumping Sites, Unmanaged Runoff, and Unusual Conditions.

Habitat data was collected based on the EPA's Rapid Bioassessment Protocols (Barbour et al. 1999). This information was used to characterize general habitat quality throughout characteristic sections of open channel.

See **Table 4.1** for summary of field data collected within each subwatershed, which lists the frequency of occurrence of each collected feature type. A description of the detailed information noted for each point type is listed in **Appendix B**. The following data were collected for each problem point identified along the stream network during the field effort:

- **Location:** A tablet leveraging the Collector for ArcGIS app was used in conjunction with an external Global Positioning System (GPS) to record a geographic location at sub-meter accuracy and information at each point. The Collector for ArcGIS app uploads the collected features to a web map hosted on ArcGIS Online. Photographs were taken to document location characteristics.
- **Severity:** A ranking was assigned based on a comparison with other problem sites observed in the Watershed.
- **Correctability:** A ranking was assigned based on the extent of the problem and the approximate dollar amount and labor required to correct the observed condition.
- **Accessibility:** A ranking was assigned based upon distance from public roads, slope, vegetation and property ownership surrounding the problem site.

The ArcGIS web map link for all data collected along the 83,000 linear feet of Smith Branch channel network will be available to the City upon completion of the study. With appropriate server capabilities and/or through conversion to a GIS platform, the data on the web link can be maintained and utilized as an effective watershed management tool.

## **4.2 Watershed Characterization**

The comprehensive field effort provided valuable insight into the existing conditions and nature of stressors within in the watershed. Extensive development and urbanization throughout the watershed has greatly influenced existing conditions within the stream network, resulting in extensive channelization, infrastructure encroachments, utility conflicts and conversion of headwater stream channels to closed storm drain systems. Channel longitudinal connectivity is severely disrupted and floodplain connectivity is either non-existent or simply inadequate for most of the watershed. Open channels are often altered through infrastructure encroachment and concrete lining. In locations where the channels are not armored, flashy high energy flows are eroding the channel bed and banks. Channel incision and widening threatens existing infrastructure, including sanitary lines, in numerous locations throughout the watershed. Limited to no stormwater management and an excessive amount of impervious surface in the headwater uplands has negatively impacted the downstream network, resulting in widespread instability,



**Table 4.1 Data Collected During the Stream Cruising Effort**

Sub-watershed	Bedrock (#)	Channel Alteration (linear feet)	Erosion Site (linear feet)	Exposed Pipe (#)	Habitat Assessment (#)	Inadequate Forest Buffer (linear feet)	Near Stream Construction (#)	Pipe Outfall (#)	Possible Fish Barrier (#)	Rep. Photo Site (#)	Trash Dump Site (#)	Unman. Runoff (#)	Unusual Condition (#)
SW-A	3	2,475	1,001	1	5	6,125	0	15	0	44	0	1	13
SW-B	3	1,507	2,241	6	4	7,942	0	13	5	52	0	7	11
SW-C	1	631	403	2	4	1,554	0	9	1	33	1	0	5
SW-D	4	5,121	1,268	24	11	13,613	1	43	7	116	0	11	19
SW-E	11	234	4,901	4	5	2,433	0	29	1	81	1	3	11
SW-F	0	79	0	0	1	1,909	1	8	1	5	0	0	3
SW-G	2	121	1,006	2	2	1,092	1	16	1	34	0	2	4
SW-H	0	0	0	0	0	0	0	0	0	0	0	0	0
SW-I	0	885	664	2	3	6,795	0	22	1	51	0	3	4
SW-J	0	1,934	1,380	3	5	2,670	0	12	1	63	1	7	15
SW-K	5	1,674	2,912	10	9	4,413	0	19	6	43	0	6	10
SW-L	7	843	9,534	8	7	3,515	0	17	6	22	3	5	10
SW-M	2	226	2,255	0	5	532	1	6	0	29	0	0	1
<b>Totals</b>	<b>38</b>	<b>15,731</b>	<b>27,565</b>	<b>62</b>	<b>61</b>	<b>52,593</b>	<b>4</b>	<b>209</b>	<b>30</b>	<b>573</b>	<b>6</b>	<b>45</b>	<b>106</b>



water quality and storage issues. Poor water quality and a deficiency of suitable and stable habitat have limited development of a biological community throughout the watershed.

#### 4.2.1 Subwatershed Breakouts

The watershed was divided into logical yet manageable subwatersheds for a more detailed evaluation. Utilizing information from the stream cruising effort and the SWMM model, the watershed was divided into thirteen subwatersheds, as shown in **Figure 4.2**. These subwatersheds were primarily selected based on hydrologic breaks within the watershed. Most of the subwatershed breaks occur at major confluences or road crossings representing a change in channel and/or floodplain condition. The detailed drainage boundaries of each area were derived by evaluating the topography, storm drain network and digital maps of impervious surfaces.

To compare and prioritize subwatersheds, the data collected from the stream cruising effort were reviewed to identify areas with a density of problem sites. A large portion of these data refer to small scale details within the stream system, which required physical observation of field conditions. Data representing the larger scale characteristics of the watershed, including land use, property ownership, and soils, were evaluated using GIS. A combination of the field data, GIS and hydrology and hydraulic analysis will be used to identify subwatersheds where restorative efforts should be focused.

### 4.3 Hydrologic and Hydraulic (H&H) Analysis

#### 4.3.1 Previous Studies

Water surface models and the associated data and documentation were collected from sources including the City of Columbia and the Federal Emergency Management Agency (FEMA). The McCormick Taylor/KCI Team has incorporated all available H&H data for the Smith Branch Watershed. A summary of the origin of the data used in these models and the validity of the assumptions that were used is provided below. The previous studies used in our analysis include the following:

- 1994 FEMA FIS
- 2010 FEMA Flood Insurance Study (FIS)
- 2015 Conditional FEMA FIS
- 2005 DHEC Total Maximum Daily Load for Fecal Coliform - Upper Broad River Basin
- City GIS Layers

##### 4.3.1.1 1994 FIS

The initial FIS for Richland County has an effective date of 1994. In the January 1994 FIS, the discharges for the revised hydrologic analyses for Smith Branch in the City of Columbia were developed from the hydrologic analyses from the City of Columbia 1987 FIS. Smith Branch was completely restudied for the January 19, 1994 FIS. Within the unincorporated areas of Richland County and the City of Columbia, water-surface elevations for Smith Branch were computed using the HEC-2 step-backwater computer program and the HEC-1 Dam Break Program. Cross sections and structural information used in the hydraulic analyses were obtained by field surveys, photogrammetric methods, and information obtained from topographic maps at a scale of 1"=200' with a contour interval of 5 feet. The HEC-2 model was first used to develop elevation-discharge ratings for dams and other hydraulic structures. The HEC-1 model was used to route



the various floods through the reservoirs and determine the amount of overtopping that would occur at each structure.

#### 4.3.1.2 2010 FIS

In 2010, Smith Branch was studied to 18,930 feet above its confluence with Broad River. The 2010 FIS states that the floodplains along Smith Branch are mostly undeveloped, but that future development in the area is expected and floodplain management information is needed to prevent unwise use of the floodplains. In order to reduce the risk of property damage in areas where the stream velocities are high, the community may wish to restrict development to areas outside the floodway.

Soils in Richland County are generally excessively drained silty sands and loams with local deposits of rock and gravels. In the creek bottoms, soils generally consist of alluvial sands and silt blanketed with finer (clay) soils with local deposits of sands and gravels. According to the 2010 FIS, Smith Branch, Eightmile Branch and the other streams studied in detail are capable of reaching developed property at various locations, and during major floods, they could cause significant damage.

In the 2010 Study, Smith Branch is noted to have a basin size of 7.36 square miles, and flows are given at four points along the watershed. Smith Branch was not restudied in detail for the 2010 FIS, so none of its discharges were revised for the 2010 FIS. Discharges modeled in the 2010 FIS are included in **Table 4.2**.

**Table 4.2 2010 FIS Discharges**

Smith Branch	Area (sq. mi)	10-year (cfs)	50-year (cfs)	100-year (cfs)	500-year (cfs)
At mouth	7.36	2,681	3,867	4,435	5,672
At confluence with Bay Branch	5.35	2,286	3,297	3,781	4,836
Above confluence with Bay Branch	2.36	1,727	2,590	2,994	3,973
At Colonial Drive	1.91	1,399	2,129	2,494	3,407

Near the mouths of streams studied in detail, floodway computations are made without regard to flood elevations on the receiving water body. Therefore, "Without Floodway" elevations presented in the 2010 FIS for certain downstream cross sections of Smith Branch are lower than the regulatory flood elevations in that area, which must take into account the 100-year flooding due to backwater from other sources. For Smith Branch, cross sections A-AB are given in the 2010 FIS with distances up to 18,930 feet above the Broad River.

#### 4.3.1.3 2015 Conditional FIS

The 2015 Conditional FEMA FIS gives a stream length of 3.8 miles for Smith Branch. It includes Smith Branch Tributary 1, with a stream length of 0.6 miles, which intercepts Smith Branch near Mountain Drive and extends to 0.1 mile upstream of Woodridge Drive, and Bay Branch, with a stream length of 2 miles, which intercepts Smith Branch near Highway 277. According to the 2015 FIS, Smith Branch and Bay Branch are capable of reaching developed property at various locations, and during major floods could cause significant damage. Along Bay Branch between Sunset Drive and the City of Columbia corporate limits, several residential



structures are located dangerously close to the stream. During major floods some of these structures will be subjected to deep flooding and high water velocities. The 2015 FIS still notes that the Smith Branch floodplain is mostly undeveloped at this time. It goes on to state that development in the area is expected and floodplain management information is needed to prevent unwise use of the floodplains.

The United States Geological Survey (USGS) Gage 02162093 for Smith Branch at North Main St at Columbia, SC has a period of record from 1977 to present, with a computed basin size of 5.69 square miles and a published basin size of 5.67 square miles. This gage has a published stage-discharge rating. Flows from the 2015 FIS are listed below (Table 4.3) for several points within the watershed. The flows increased for the 500-Year event by 10 to 20% compared to those in the 2010 FIS. The peak flood discharges for the storm events for Smith Branch were studied by detailed methods using the United State Army Corps of Engineers (USACE) HEC-HMS.

Table 4.3 2015 Conditional FIS Discharges

Smith Branch	Drainage Area (sq. mi.)	10-year (cfs)	25-year (cfs)	50-year (cfs)	100-year (cfs)	500-year (cfs)
Approximately 700 feet upstream of Preston Drive	0.75	633	856	1,049	1,264	1,842
At Colonial Drive	2.18	1,858	2,503	3,054	3,689	5,093
Immediately upstream of confluence with Bay Branch	2.63	1,083	1,357	1,543	2,022	3,392
At Main Street	5.68	2,364	3,149	3,749	4,384	6,901
At mouth (confluence with Broad River)	7.68	2,206	2,752	3,231	3,999	6,470

Manning’s n-values were estimated using community provided Digital Ortho-imagery for both channel and overbank areas. Manning’s n-values ranged from 0.04 to 0.052 for the channel and from 0.04 to 0.15 for the overbanks. Hydraulic cross section geometries were obtained from LIDAR data. Hydraulic structures were field surveyed to obtain elevation data and structural geometry. The 2015 FIS uses cross sections A-P, extending 19,904 feet above the mouth of Smith Branch at its confluence with the Broad River.

If applicable, a tie-in water-surface elevation was used as the starting condition for various hydraulic models. Otherwise, model starting conditions were set to normal depth using starting slopes calculated from channel elevation values taken from the LIDAR data.

The floodways presented in this study were computed for certain stream segments on the basis of equal conveyance reduction from each side of the floodplain. Floodway widths were computed at cross sections. Between cross sections, the floodway boundaries were interpolated. In order to reduce the risk of property damage in areas where the stream velocities are high, the FIS recommended that the community may wish to restrict development to areas outside the floodway.



#### 4.3.1.4 GIS Layers

The City GIS layers provided included storm drain information and a basin boundary. In the GIS layers for the storm drains, the nodes and links start at Smith Branch and extend outward into the watershed. The layers are mostly complete, but there is little elevation information provided. Most culverts and trunk lines are accounted for with diameters and pipe material. From a review of aerial photographs, the stormwater BMP Layer appears to have captured most of the wet and dry ponds. It is unknown at this point how many underground BMPs may not have been included. The City GIS layers did not include a total impervious layer, as with other parts of the City. Instead, the USGS's National Land Cover Database Developed Imperviousness 2011 layer was used, which is based on a land classification from 2011 Landsat satellite data.

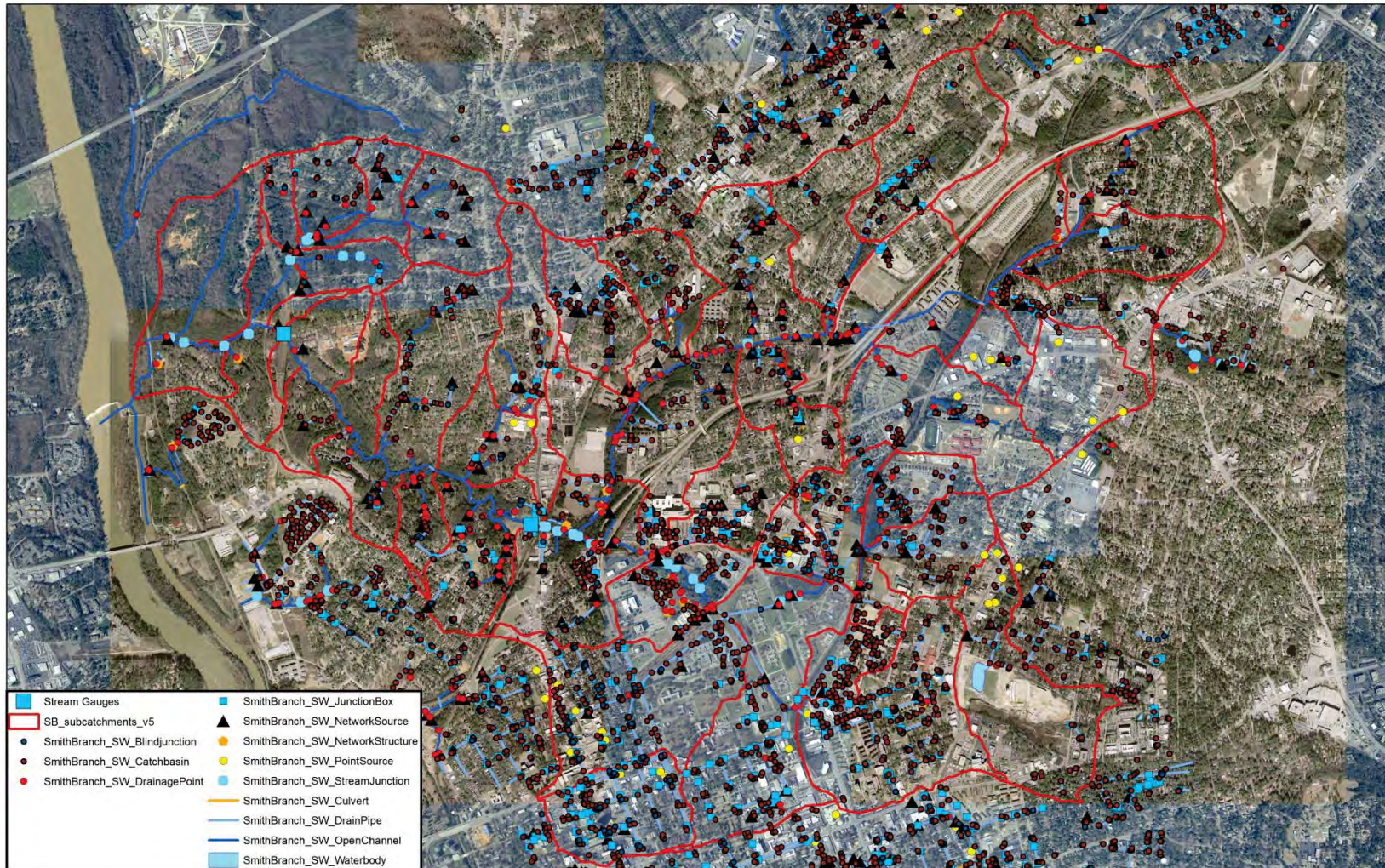
The node and conduit data from GIS for the Smith Branch Watershed are shown in **Figure 4.3**.

#### 4.3.2 Model Development

The McCormick Taylor/KCI team prepared H&H models for the Smith Branch Watershed intended for planning-level assessments of flooding and stream erosion. EPA's Stormwater Management Model (SWMM) was used for hydrologic calculations, and to determine flows in Smith Branch at various points. Unlike other hydrologic models such as TR-20 or HEC-HMS, SWMM was originally designed with urban hydrology and storm drain flows in mind. SWMM is also capable of being run either for single events or for continuous rainfall. The nature of the flooding issues in Smith Branch Watershed and the need to quantify flood frequencies leads to a requirement for continuous modeling.

In order to model the Smith Branch Watershed, the watershed was first divided into 13 subwatersheds averaging about 250 acres each and then further separated into 60 subcatchments ranging in size from 10 to 216 acres, with an average size of 79 acres. The subcatchments were created by further subdividing the subwatersheds based on topography and the storm drain network. Available data from various sources, such as digital maps of impervious surfaces and the urban storm drain network were incorporated in the model.

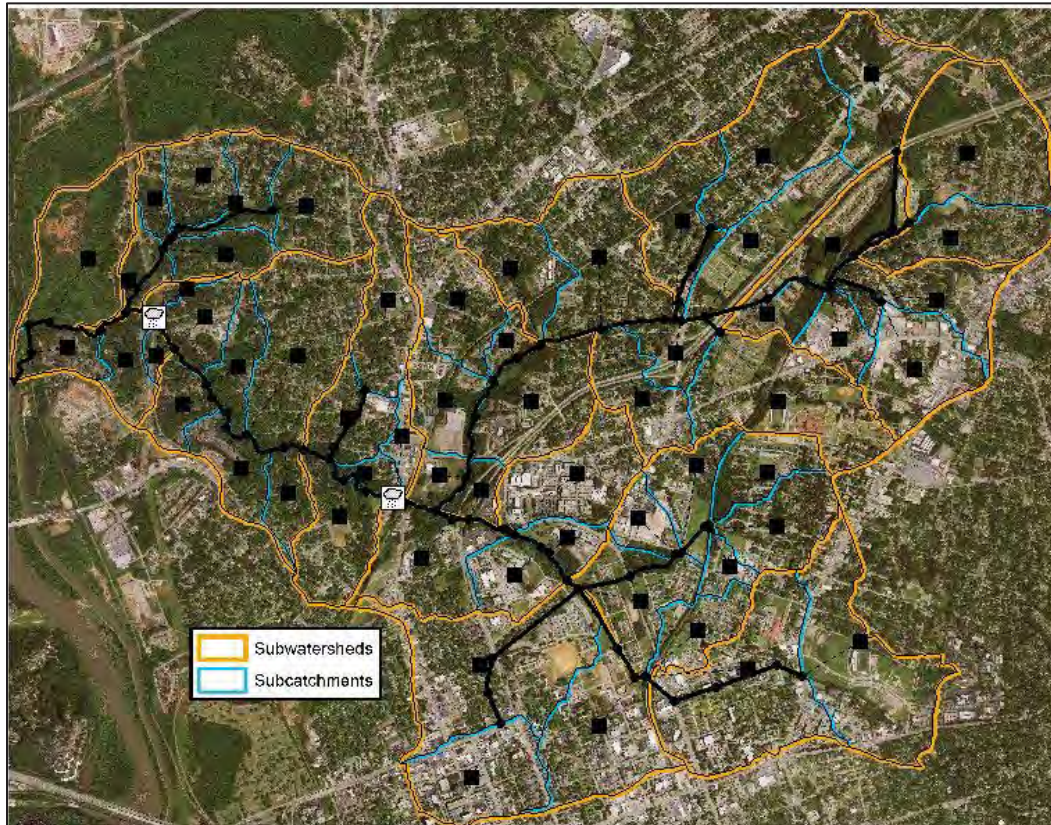
Figure 4.3 GIS Storm Drains, Nodes, and Links





The SWMM model was calibrated using the latest stream stage and precipitation data from two gages at different points in the watershed, the City of Columbia's gages A and B. Rainfall data, 15-minute or 5-minute, from the rain gage in closest proximity to the subcatchment was used as the source of precipitation. The rain gage locations and subcatchment boundaries, as modeled in SWMM, are shown in **Figure 4.4**.

**Figure 4.4 SWMM Model Layout**



For hydrologic modeling, infiltration is modeled explicitly as part of runoff calculations. The most recent soils data available from the United States Department of Agriculture (USDA) were used to determine the soils present in each subcatchment and the infiltration and run-off characteristics of the subcatchment (NRCS, 2016).

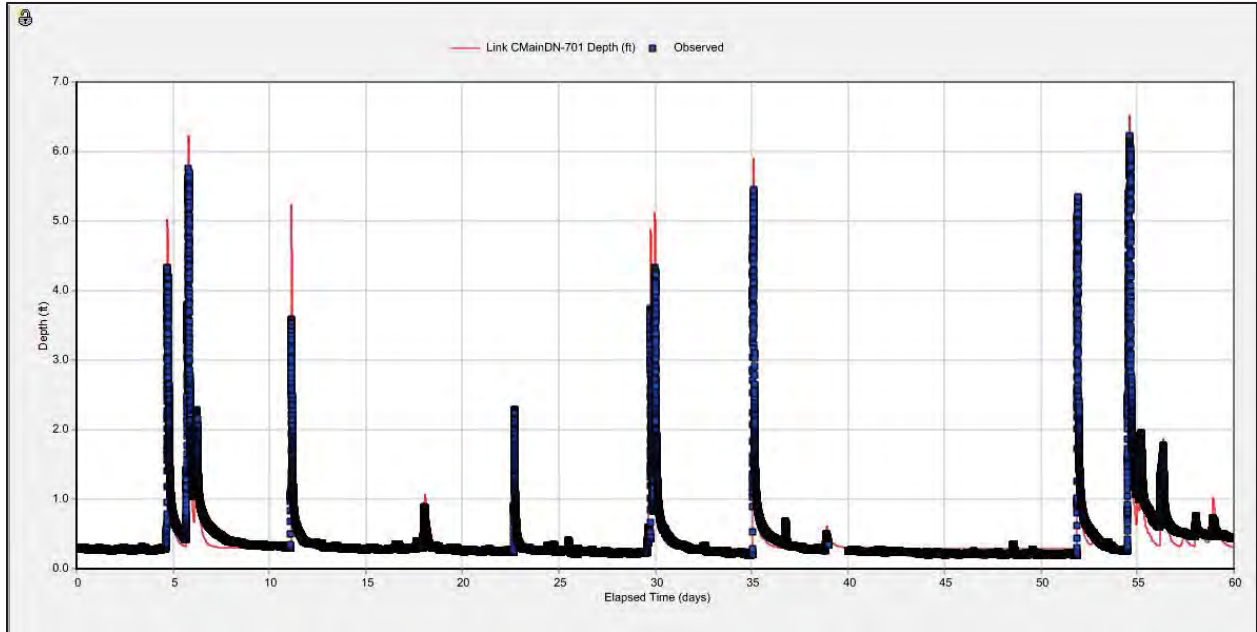
Storm drain maps and data were used to model large pipes and culverts as necessary. Trunk lines are included in the SWMM model in order to provide connectivity for all subcatchments. Stream cross sections from the 2015 HEC-RAS model developed for the Draft FIS were used in SWMM, where available, to provide better calculations of flows for input to the hydraulic model. The channel cross section at the Smith Branch Gage B was surveyed, and the dimensions for the Smith Branch tributaries were estimated from the stream assessments performed as a part of this project. Site visits were also performed to check the accuracy of the model geometry.

The stream stage data from the two gages was used to help calibrate the SWMM Model. For each event modeled, water surface elevations were compared to gage data. The model subcatchment parameters were then adjusted so that the modeled depths attained a reasonable approximation to the elevations measured at the gage. Comparisons with historic events were

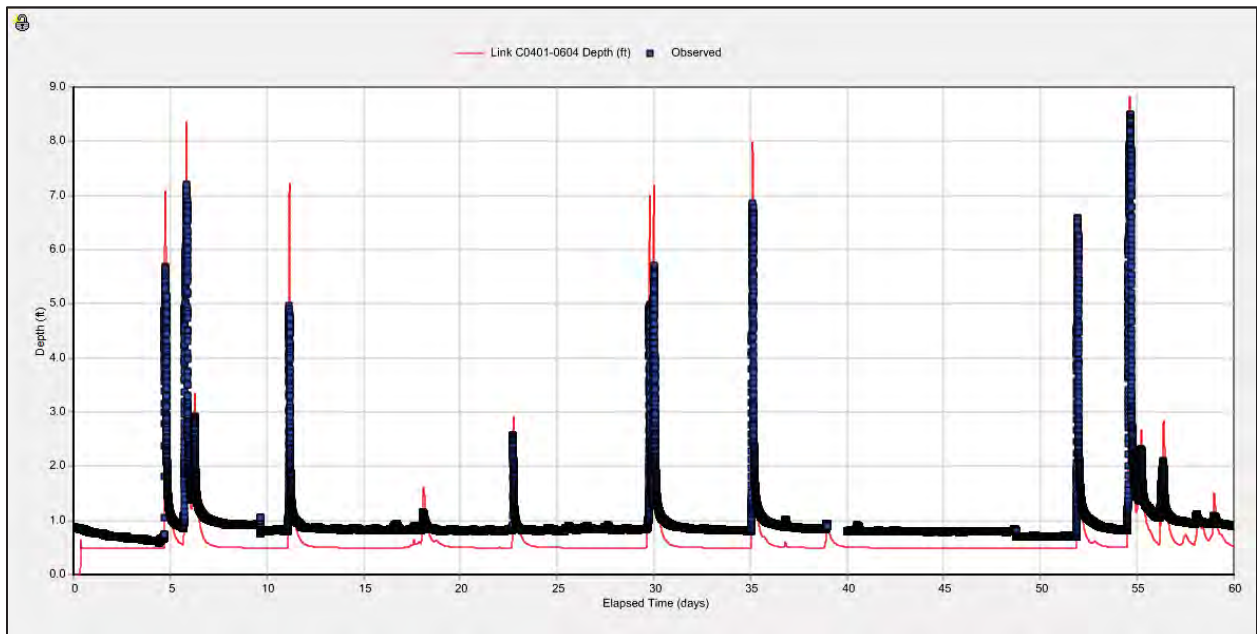


also made to determine if the model represents roadway overtopping or flooding that actually occurred. The results of the SWMM Model were compared to depths from the Stream Gage A at Earlewood Park and at Stream Gage B at the Clement Road Crossing. Flows from the USGS Gage just above Clement Street were also used in the calibrations. The time period from August 1, 2015 to October 1, 2015 was used for calibration. The gages were out of commission for over a week after a storm on October 2, 2015. The calibration results are shown in **Figures 4.5, 4.6, and 4.7.**

**Figure 4.5 Smith Branch Gage A (Main St)**

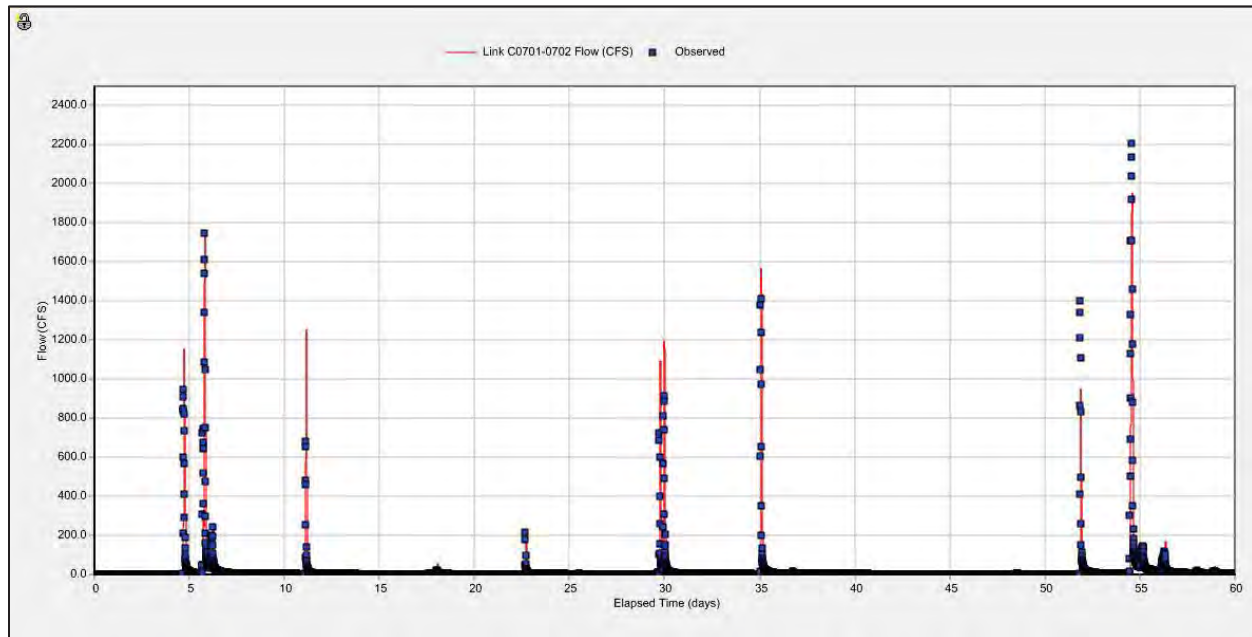


**Figure 4.6 Smith Branch Gage B (Clement Rd.)**





**Figure 4.7 USGS Flow (Clement Rd.)**



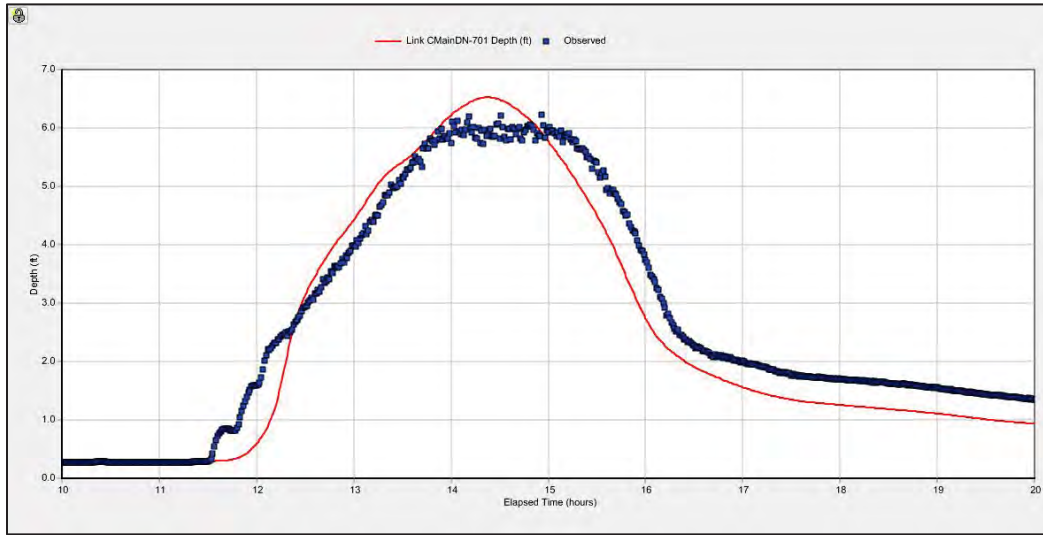
The SWMM Model produced reasonably accurate peaks at both depth gages. At the USGS Gage, near the Smith Branch Gage A location, the flows were created from a well-established rating curve, and compared to the flows from SWMM at this location. The purpose of the SWMM Model was not to predict peaks, but rather to estimate flows for use in HEC-RAS; however both peaks and flows were reasonably well-represented by the SWMM Model. Unlike the SWMM Model, the HEC-RAS model contains bridge, culvert and utility crossings. Once the SWMM Model calibration was completed, the 2, 10, 25, 50 100 and 500-year design storms were simulated through the SWMM Model, each as a single event. This produced flows along Smith Branch that were input into the HEC-RAS model at the specified river stations.

### 4.3.3 Gage Results in HEC-RAS

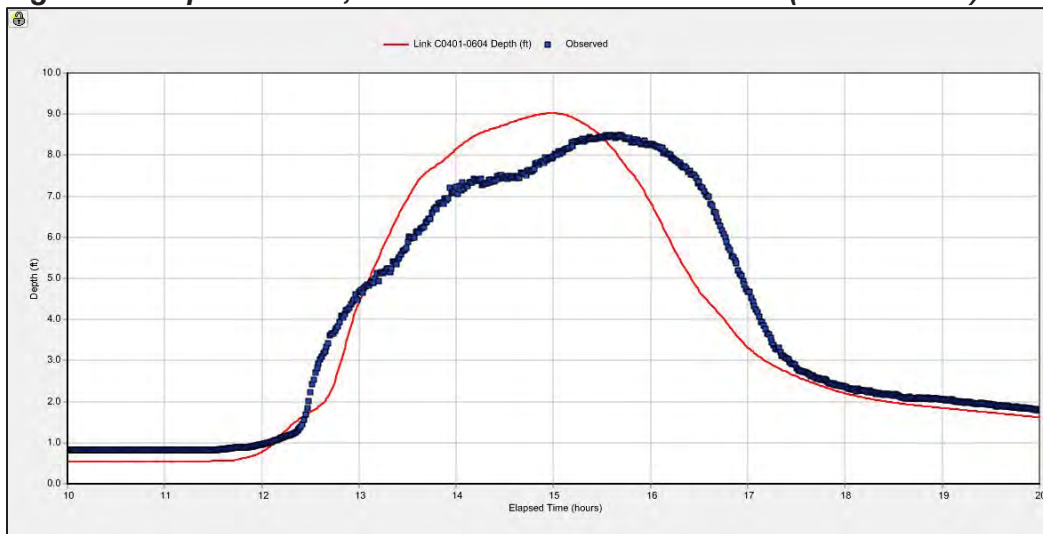
A storm that occurred on September 25, 2015 produced approximately 3.52 inches of rain in 6 hours, similar to the 10-year, 6-hour National Oceanic and Atmospheric Administration (NOAA) event for this area. The storm was also run in the HEC-RAS model to compare its output. Flows from the September 25, 2015 Storm, when run in HEC-RAS, produced a depth of 8.97 feet at the approximate location of the USGS Gage. Data from the Smith Branch B Gage in this area shows a slightly lower depth of 8.5 feet. The results from SWMM for this same storm are shown in **Figures 4.8** and **4.9** at Stream Gages A and B, respectively.



**Figure 4.8 September 25, 2015 Storm at Smith Branch A (Main St.)**



**Figure 4.9 September 25, 2015 Storm at Smith Branch B (Clement Rd.)**



#### 4.3.4 Water Surface Profile Evaluation

The Hydraulic Analysis to determine water surface elevations (WSEs) for this study was done by taking the flows generated from SWMM and running them in the HEC-RAS model. The Smith Branch HEC-RAS model from the 2015 Conditional FIS was utilized for this effort. The 2015 HEC-RAS model used the most recent survey, and represented the most accurate channel conditions. The HEC-RAS model was then field verified as a part of this study. Once the updated model geometries were compiled, channel crossings and roughness values were evaluated in the field to ensure the model accurately depicts watershed conditions.

The proposed improvements focus primarily on new cross section recommendations at crossings that play a large role in controlling water surface profiles. The hydrologic flow data in the models has been updated to reflect the data developed from the spatially-distributed rainfall-runoff relationships, updated stormwater network, and the streamflow calibrations from available gage data. These updated models can then be used to show the extent of areas of flooding



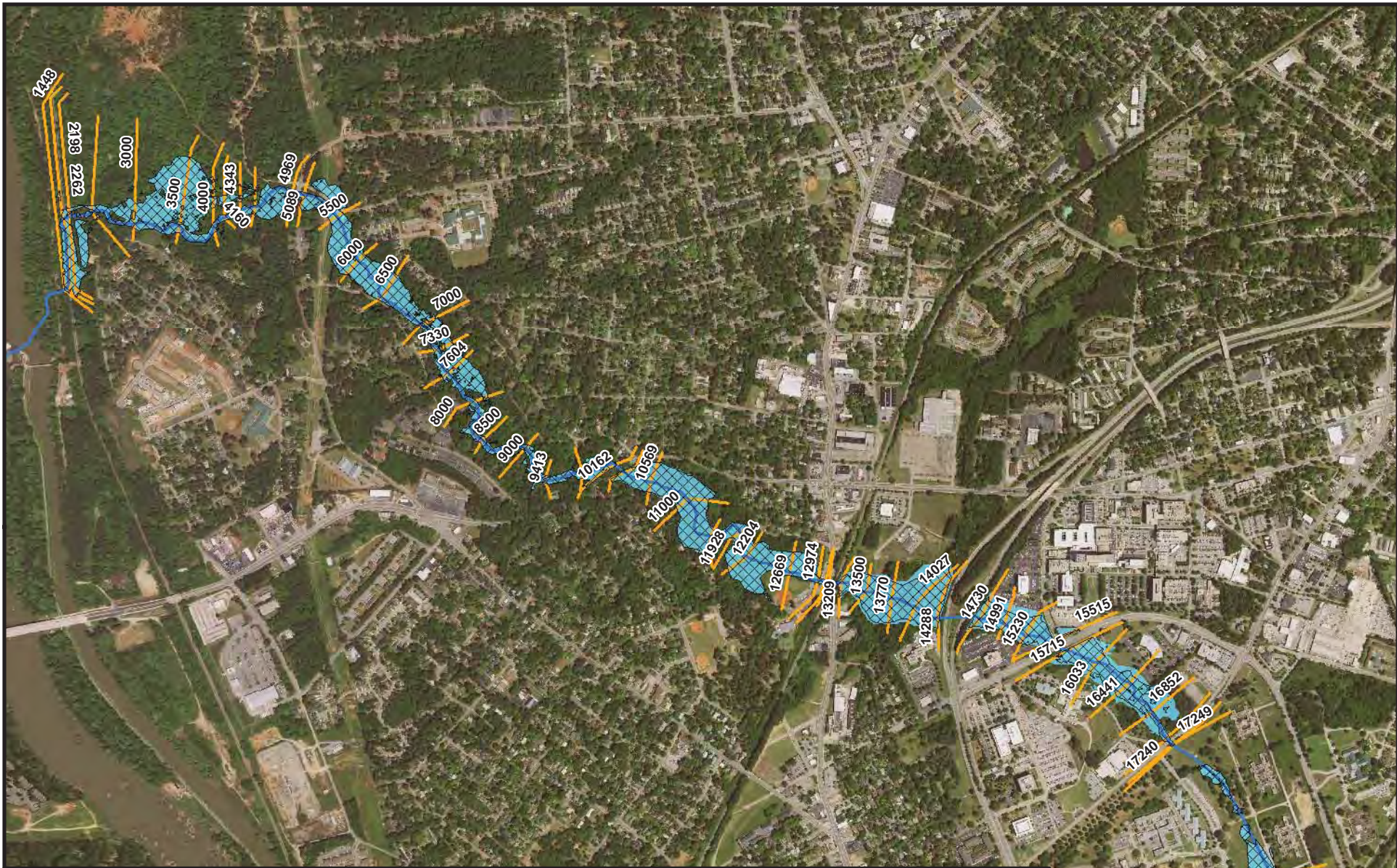
concern in conjunction with the mapped FEMA floodplains. HEC-RAS River Station (RS) locations are shown in **Figure 4.10**.

#### 4.3.5 Flow Results

The flows used in the Preliminary 2015 FIS HEC-RAS Model from HEC-HMS (**Table 4.4**) in the downstream areas are notably higher than the ones produced from the 2016 SWMM Model (**Table 4.5**) for the 100 and 500-year events. The HEC-RAS Flows from the 2015 FIS are closer to flows predicted from the Alternative Urban Regional Regression equations for South Carolina or Smith Branch with a four mile stream length, and 36.8% overall imperviousness (USGS, 2004). The SWMM flows are higher than the USGS regional flood-frequency equations for ungaged urban and small, rural streams in Georgia, South Carolina, and North Carolina (USGS, 2014) (**Table 4.5**).

**Table 4.4 2015 Conditional FIS Existing HEC-RAS Flows**

RS	2-year (cfs)	10-year (cfs)	25-year (cfs)	50-year (cfs)	100-year (cfs)	500-year (cfs)
19904	500	633	856	1,049	1,264	1,842
19500	550	927	1,241	1,498	1,839	2,697
17240	1,500	1,858	2,503	3,054	3,689	5,093
16852	1,400	1,576	1,890	2,499	3,003	4,036
15715	1,400	1,558	1,832	2,340	2,904	3,932
15230	800	1,083	1,357	1,543	2,022	3,392
13770	2,000	2,364	3,149	3,749	4,384	6,901
13209	2,000	2,259	2,780	3,434	4,058	6,846
10569	2,000	2,243	2,749	3,401	4,058	6,893
8500	2,000	2,242	2,755	3,267	3,995	6,591
4500	2,000	2,268	2,795	3,297	4,046	6,653
2500	2,000	2,206	2,752	3,231	3,999	6,470



**Figure 4.10: HEC-RAS RS Locations and 10-Year Results**

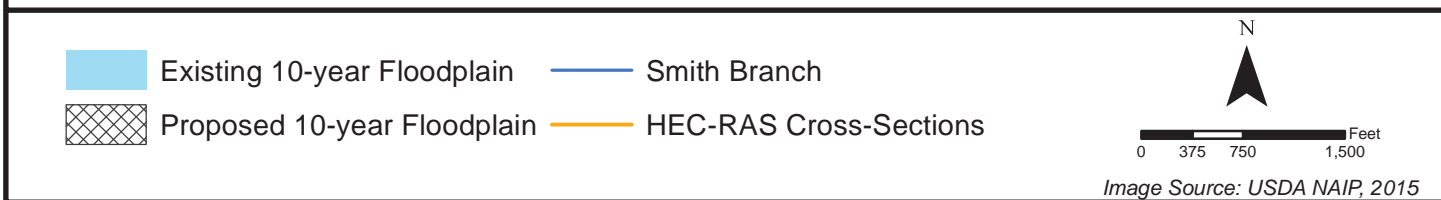




Table 4.5 Updated HEC-RAS Flows from 2016 SWMM

RS	2-year (cfs)	10-year (cfs)	25-year (cfs)	50-year (cfs)	100-year (cfs)	500-year (cfs)	Sept. 25, 2015 Storm (cfs)
19904	445	850	1,002	1,019	1,086	1,525	379
19500	574	913	1,105	1,228	1,330	1,687	511
17240	1,400	1,607	1,617	1,616	1,613	1,613	1,163
16852	1,399	1,596	1,597	1,597	1,597	1,597	1,163
15715	1,417	1,674	1,710	1,745	1,790	1,866	1,207
15230	1,498	1,785	1,872	1,944	2,025	2,232	1,257
13770	1,823	2,165	2,307	2,379	2,440	2,554	1,958
10569	1,818	2,175	2,343	2,454	2,548	2,766	1,956
8500	1,794	2,174	2,358	2,486	2,599	2,885	1,951
4500	1,793	2,200	2,423	2,583	2,752	3,245	1,964
2500	1,778	2,184	2,396	2,583	2,765	3,321	1,950

Table 4.6 USGS Calculated Peak Flows compared to 2016 SWMM Peaks for Smith Branch

Storm Event	Alternative Urban Regression Equations (cfs)	Regional Flood-Frequency Equations (cfs)	2016 SWMM (cfs)
10-year	2,885	1,888	1,823
25-year	3,347	2,203	2,422
50-year	3,713	2,409	2,583
100-year	4,052	2,667	2,599
500-year	4,975	2,882	3,245

Flows more similar to the lower flows from the USGS Regional Flood-Frequency Equations and 2016 SWMM were also calculated for the vicinity of Colonial Drive. These flows were calculated by Pace Engineering in 2014, for an estimated 2.1-square mile basin, as shown in Table 4.7, with the flows from SWMM for comparison.

Table 4.7 Comparison of Estimated Colonial Drive Flows

Model	2-year (cfs)	10-year (cfs)	25-year (cfs)	50-year (cfs)	100-year (cfs)	500-year (cfs)
2014 Pace	747	1,080	1,260	1,370	1,520	1,800
2016 SWMM	1,400	1,607	1,617	1,616	1,613	1,613



Flows and drainage areas from the current 2016 SWMM Model for Bay Branch were also compared to those from the 2015 Conditional FIS. The flows from both models are included in **Table 4.8** and **Table 4.9**.

**Table 4.8 Bay Branch Drainage Areas and Flows from 2015 Conditional FIS**

Location	Drainage Area (Sq. Mi.)	10-year (cfs)	25-year (cfs)	50-year (cfs)	100-year (cfs)	500-year (cfs)
Approximately 0.4 miles upstream of SC HWY 277	1.17	845	1,194	1,503	1,851	2,806
Approximately 100 feet upstream of Shaw Street	2.17	1,277	1,694	2,004	2,372	3,363
Approximately 100 feet upstream of Grand Street	2.41	1,430	1,885	2,252	2,671	3,840
Approximately 1,600 feet upstream of Sunset Drive	2.98	1,558	2,002	2,480	2,979	4,414

**Table 4.9 Bay Branch Drainage Areas and Flows from 2016 SWMM Model**

Location	Drainage Area (Sq. Mi.)	10-year (cfs)	25-year (cfs)	50-year (cfs)	100-year (cfs)	500-year (cfs)
Approximately 0.4 miles upstream of SC HWY 277	1.05	1,014	1,217	1,217	1,629	2,163
Approximately 100 feet upstream of Shaw Street	2.06	1,739	2,143	2,143	2,754	2,846
Approximately 100 feet upstream of Grand Street	2.39	2,070	2,617	2,617	3,367	3,407
Approximately 1,600 feet upstream of Sunset Drive	2.86	1,664	1,801	1,801	2,053	2,294

Drainage areas used for Bay Branch in the 2016 SWMM Model are slightly smaller, but still within 5% of the FEMA values. Flows from the areas near Shaw Street and Grand Street are notably higher in the SWMM Model. This result is believed to be due to the concrete channelization of this area; the steeper slopes and lower Manning’s n, 0.012 for concrete, produce a higher flow result. Further downstream where the channel returns to a more natural condition, the water slows and flooding occurs at the confluence of Smith and Bay Branch. This is also in an area where the effects of the undersized culvert crossing at Main Street are causing flooding. The results from the SWMM Model suggest that restoring the concrete channel to a more natural condition, and upgrading the culvert at Main Street would reduce isolated flooding in this area. The 25-year and 50-year events give identical results in the SWMM Model likely due to flow from the 50 year event being stored in the model as flooding at various nodes.



### 4.3.6 Results from Culvert Analysis

For Smith Branch, four model scenarios were created in HEC-RAS with the updated flows: Existing Conditions, Natural Channel Scenario and two Proposed Conditions scenarios. The Natural Channel Scenario looks at the watershed with all the bridges from downstream of Colonial Drive down to the railroad downstream of Clement Street removed. The Preston Street Culverts and the railroad bridge do, however, remain in the model. This natural condition can then be compared to the existing and proposed conditions for water surface profile evaluation. For the proposed scenario, there is only one suggested modification to the existing culvert scenario. There are two proposed conditions scenarios. Scenario 1 is for an increased capacity dual culvert system of 12 ft x 12 ft each at Main Street. The bottleneck at Main Street is the most pronounced in the watershed, and improving this culvert crossing will have the greatest effect on improving upstream conditions for the watershed without aggravating downstream conditions. This improvement would help flooding conditions into the area where Bay Branch and Smith Branch intersect. Comparison of WSE among the three different scenarios is included in **Table 4.10**.

**Table 4.10 Culvert Analysis Scenario 1: Colonial Drive to Clement Street Culvert Replacement**

Crossing Type	RS - Name	Proposed Modification	WSE EXISTING (ft)		WSE PROPOSED (ft)		WSE NATURAL (ft)	
			10-year	100-year	10-year	100-year	10-year	100-year
Dual 7' Circular Culverts	19024 – Preston Drive Upstream		233.84	234.44	233.84	235.5	233.85	234.71
Dual 10' X 10' Culverts	17240 – Colonial Drive/Preston Drive Outfall		221.94	221.90	221.94	221.97	217.12	217.13
Dual 12' X 10' Culverts	15715 - South Harden St		217.00	219.46	214.55	215.12	211.61	211.98
Dual 12' X 12' Culverts	14730 - Highway 277		215.77	218.14	211.64	212.61	209.73	210.17
16' X 12' Arch	13209 - Main Street	Dual 12' X 12' Culverts	214.61	216.81	209.18	210.07	208.13	208.79
Bridge	13046 - Parkside Drive		204.76	205.23	204.76	205.14	204.76	205.23
	11928		200.84	202.47	200.57	201.53	200.01	200.43
Dual 10' X 9' Culverts	10282 – Sunset Drive		199.66	201.79	199.11	200.43	192.05	192.51
	7000		176.23	176.81	176.41	177.03	176.22	176.78
Bridge	5089 – Clement Road		171.86	172.68	171.86	172.68	171.00	171.53
Bridge	2262 – Railroad		158.42	159.19	158.42	159.19	158.42	159.19

Upgrading the culverts at Sunset Drive to dual 12 ft x 12 ft culverts was then studied as proposed scenario 2. This change would bring the upstream (Sunset Drive) WSE down to 197.74 feet and 198.90 feet for the 10-year and 100-year events, respectively. The improvements from this



upgrade appear to be localized, however, and would not reduce the floodplain elevations much upstream or downstream of this area. It would improve the flooding conditions at the back of Keenan Drive. Properties there are currently mapped within the 1% annual chance floodplain in the 2015 Preliminary FIS. The results for the two culvert scenarios are provided in **Table 4.11**.

**Table 4.11 Culvert Analysis Scenario 2: Sunset Drive Culvert Upgrade**

Crossing Type	RS - Name	Proposed Modification	WSE EXISTING (ft)		WSE PROPOSED Main Street Culvert Upgrade (ft)		WSE PROPOSED Main Street and Sunset Drive Culvert Upgrade (ft)	
			10-year	100-year	10-year	100-year	10-year	100-year
Dual 7' Circular Culverts	19024 – Preston Drive Upstream		233.84	234.44	233.84	235.50	233.84	234.50
Dual 10' X 10' Culverts	17240 – Colonial Drive/Preston Drive Outfall		221.94	221.90	221.94	221.97	221.94	221.97
Dual 12' X 10' Culverts	15715 - South Harden St		217.00	219.46	214.55	215.12	214.55	215.12
Dual 12' X 12' Culverts	14730 - Highway 277		215.77	218.14	211.64	212.61	211.64	212.61
16' X 12' Arch	13209 - Main Street	Dual 12' X 12' Culverts	214.61	216.81	209.18	210.07	209.18	210.07
Bridge	13046 - Parkside Drive		204.76	205.23	204.76	205.14	204.76	205.15
	11928		200.84	202.47	200.57	201.53	200.17	200.81
Dual 10' X 9' Culverts	10282 – Sunset Drive	Dual 12' X 12' Culverts	199.66	201.79	199.11	200.43	197.74	198.90
	9000		183.72	184.44	183.72	184.44	183.72	184.44
Bridge	5089 – Clement Road		171.86	172.68	171.86	172.68	171.86	172.68
Bridge	2262 – Railroad		158.42	159.19	158.42	159.19	158.42	159.19

In addition to the HEC-RAS scenarios, another modification was considered. There is an existing project (Bull Street Redevelopment) ongoing where the plan is to remove the dual culverts that flow downstream from Preston Drive and create an open stream channel between Preston Drive and Colonial Drive. Although this will improve water quality and provide infiltration during small rain events, it will not add much detention to the system. This area could be studied for possible future detention, as the topography may support this approach. Underground detention or an open pond storage scenario could be considered and studied. For the purposes of this study, a 1,400 foot long, 80 foot wide trapezoidal channel with a 48 inch outfall was modeled as a detention pond to investigate the potential influence. With an outfall invert of approximately 218 feet, using the North American Vertical Datum (NAVD) standard, it provides approximately 900,000 cubic feet of storage and can almost detain the 10-year event. This facility would reduce the flow from the park from 1,600 cfs to 200 cfs during that magnitude of storm. The flow at Main Street is reduced from 2,200 cfs to 1,500 cfs in this scenario.



This pond modeling was done as a hypothetical way to look at the possibility of storage. There would be a large expense as well as issues with public perception to construct a pond of this size here. However, a regional detention project like this will allow the water from Bay Branch, and the areas of Smith Branch below this point to flow out. Water coming from the areas drained above Preston Drive would be detained, and this detention would help reduce coincident peaks in the watershed and create a flow scenario more similar to a natural condition. As Smith Branch flows to its confluence with the Broad River, it becomes less developed. In the downstream portions of the watershed, it is better for water to be allowed to use the natural floodplains and flow out than be detained.

#### 4.3.7 Model Conclusions/Recommendations

Smith Branch is a large watershed, and the SWMM Model would increase in accuracy if the number of subcatchments was increased from 60 to 80 or more. This would benefit the areas of the model where data is currently not as complete and where subcatchments are over 100 acres in size. In the northeastern portion of the watershed above SC-277, there is little storm drain network data. Further mapping in this area is recommended in order to more accurately model this subwatershed.

Limiting development within the 100-year floodplain adjacent to Smith Branch and Bay Branch will be beneficial to the entire watershed. In Smith Branch the area from SC-277 down to its mouth still has undeveloped floodplain, which should be preserved. In Bay Branch, the existing floodplain areas below Lorick Avenue should be preserved, and the altered channel above it should be restored to allow for infiltration and some storage in the floodplain. The Bull Street Redevelopment Project will provide a water quality improvement for Smith Branch. The single arch culvert at Main Street produces the highest flow constriction as water flows out of Smith Branch. Upgrading it will reduce upstream flooding. The area near Preston Drive, where the Bull Street Redevelopment Project is taking place, should be further considered for detention of runoff.

#### 4.3.8 Water Quality Data

The Smith Branch Watershed is listed in the Lower Broad River Total Maximum Daily Load (TMDL) for fecal coliform. The TMDL document states that Smith Branch is the most downstream tributary to the Broad River included in the TMDL. Water Quality Monitoring (WQM) station B-280, (Smith Branch at North Main St (U.S. Highway 21) in Columbia) located in Richland County, drains 3,583 acres and is the most urbanized watershed of the Broad River study area. Approximately 81% of the Smith Branch watershed is urban (City of Columbia), approximately 15% is forest, and row crops compose approximately 2%. The TMDL document also lists WQM station B-337 (Broad River at U.S. Highway 176 (Broad River Road) in Columbia). The watershed for WQM station B-337 is the largest included in the report, draining 160,261 acres and comprising all of Hydrologic Unit Codes (HUCs) 03050106 -050, and -060. Smith Branch is listed in HUC 03050106060.

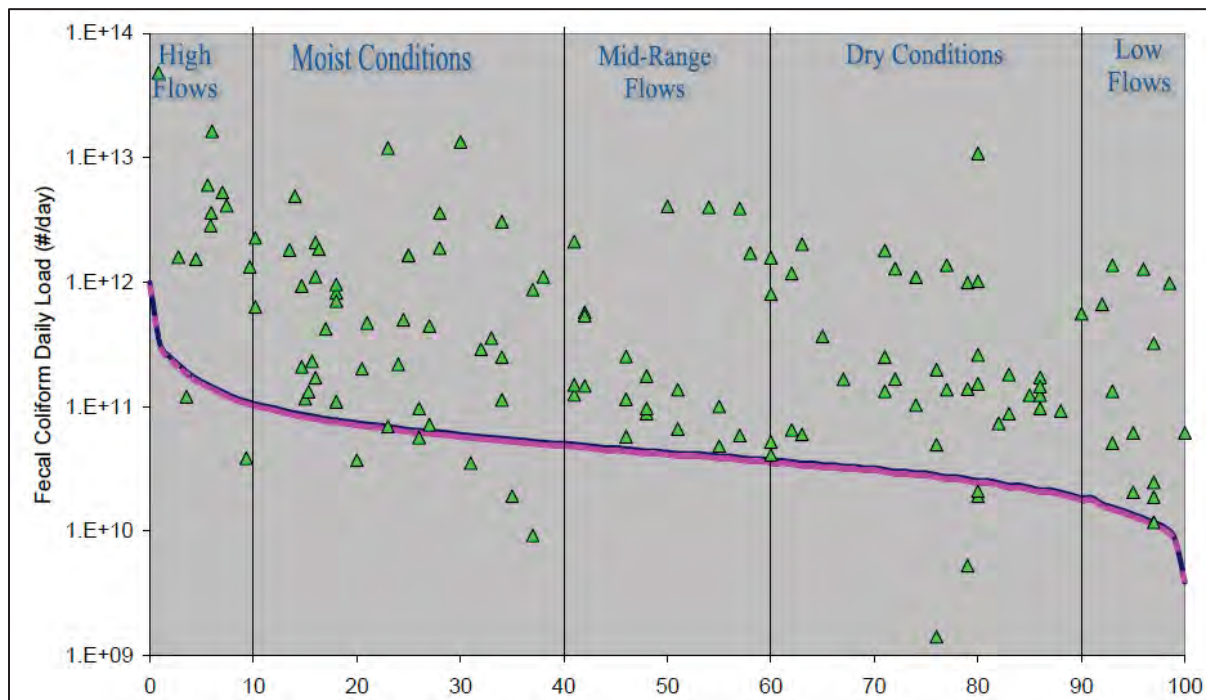
The TMDL document states that for WQM Station B-280 (Smith Branch), comparison of ambient fecal coliform data and NOAA precipitation data (82 data points) for the period examined (1994 and 2001) revealed 15 days in which the 3-day average rainfall exceeded 0.1 inches, and on those dates the fecal coliform measurements exceeded the water quality standards (WQS). There were 59 other exceedances that occurred between 1994 and 2002; however, those



occurred when there was no measurable rainfall recorded. This suggests that higher fecal coliform concentrations may be associated with wet weather conditions, but there are also sources affecting water quality during dry conditions.

Samples for 32, or 89% of the 36 water samples collected at Station B-280 from January 1998 through December 2000 exceeded the fecal coliform WQS of 400 cfu/100 ml. There is no active NPDES-permitted wastewater discharge plants (WWTP) discharging fecal coliform in this watershed. There were no SSO's reported within this watershed. There are an estimated 612 on-site waste disposal (OSWD) systems within this watershed resulting in 17.1 OSWD systems per 100 acres. The sources of fecal coliform contributing to nonsupport of primary contact recreation most probably include a combination of MS4 point sources, failing OSWD systems, leaking sewers, pets, and wildlife.

**Figure 4.11 Fecal Coliform Load Duration Curve 1990-2000, Station B-280 (Smith Branch)**

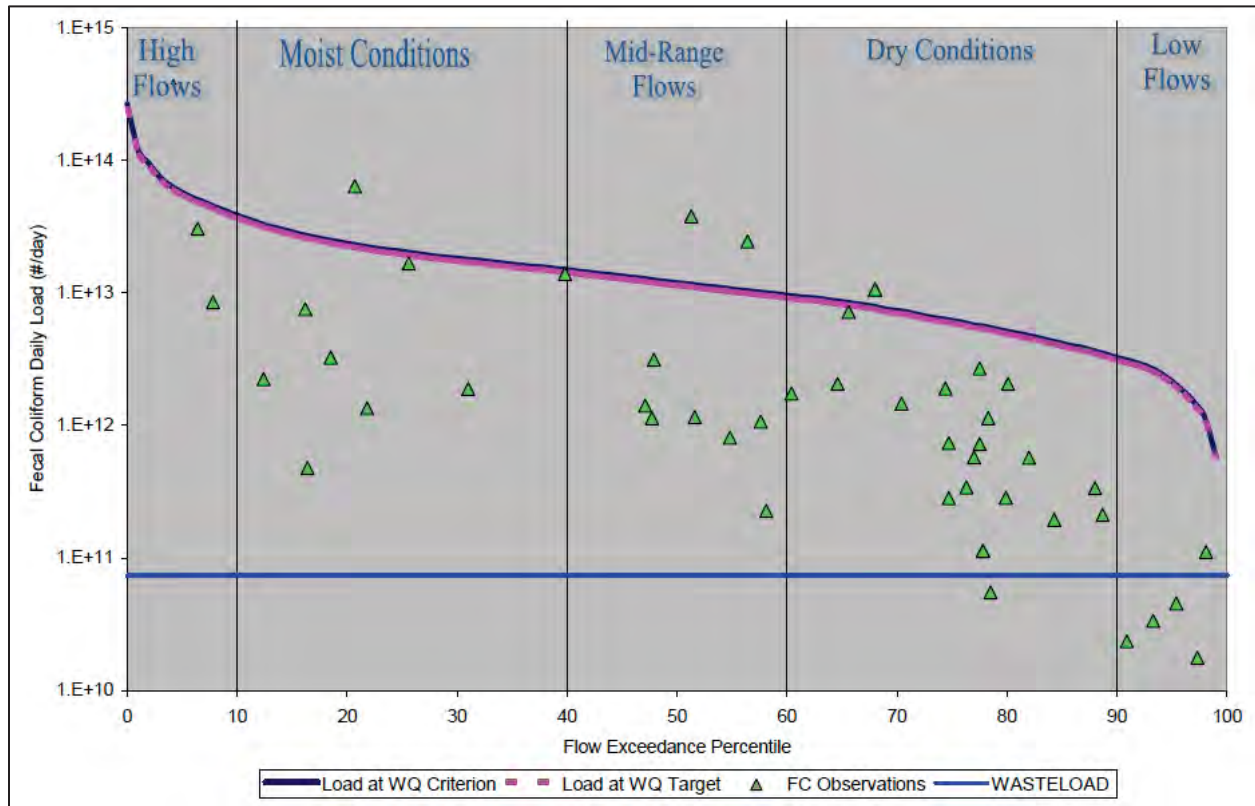


The TMDL document states that for WQM Station B-337 (Broad River), comparison of ambient fecal coliform data and NOAA precipitation data (46 data points) for the period examined (1994 and 2002) revealed four days in which the 3-day average rainfall exceeded 0.1 inches, and on those dates the fecal coliform measurements exceeded the WQS. There were two other exceedances; however, those occurred when there was no measurable rainfall recorded. This suggests that higher fecal coliform concentrations may be associated with wet weather conditions, but there are also sources affecting water quality during dry conditions.

A full report on water quality monitoring within Smith Branch is included in **Appendix C**.



Figure 4.12 Fecal Coliform Load Duration Curve 1994-2002, Station B-337 (Broad River)





## 5.0 Subwatershed Ranking

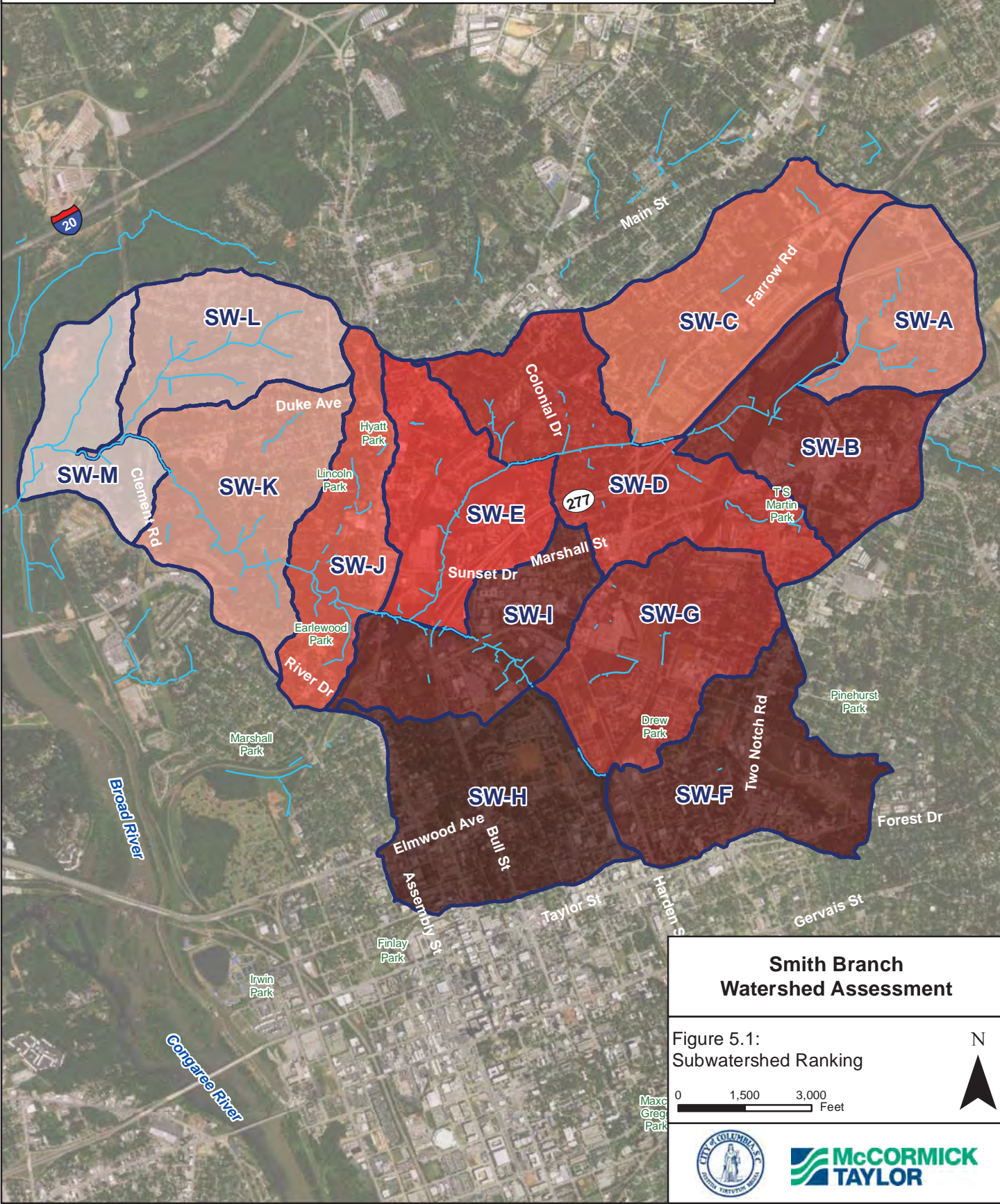
The table below details how the subwatershed runoff rankings were created for the 13 subwatersheds in the Smith Branch Watershed. These rankings in particular are based in part on a typical 2-year storm event modeled in SWMM for existing conditions. Each subwatershed was ranked on percent imperviousness, peak runoff per acre, total volume of runoff, and volume of runoff per acre to produce a total ranking where the lower the total, the higher the integrity of existing conditions for the subwatershed. Based on the 2-year event, the least impaired subwatershed for runoff was SW-M with an overall ranking of 13 and the most impaired SW-H with an overall ranking of 1. The results of the Cumulative Ranking are shown in **Figure 5.1**.

**Table 5.1 Subwatershed Runoff Rankings (2-year Storm Event)**

Sub-watershed	Acres	Impervious Cover		Peak Discharge		Total Runoff		Unit Runoff		Cumulative Ranking	
		%	Rank	cfs/ac	Rank	MIL gal	Rank	Cubic Feet/ac	Rank	Total Score	Overall Rank
SW-H	464	59%	1	1.3	5	26.1	1	7,521	1	8	1
SW-F	400	54%	2	1.4	3	20.9	2	6,970	2	9	2
SW-I	309	47%	3	1.4	2	14.1	6	6,115	3	14	3
SW-B	369	47%	4	1.3	4	16.5	4	5,986	4	16	4
SW-G	404	40%	5	1.5	1	16.0	5	5,303	5	16	5
SW-D	506	37%	7	1.2	6	17.7	3	4,686	7	23	6
SW-E	342	40%	6	1.1	7	13.0	8	5,073	6	27	7
SW-J	285	33%	8	1.1	8	9.2	9	4,292	8	33	8
SW-C	463	31%	9	1.0	9	13.6	7	3,927	9	34	9
SW-A	273	26%	10	0.1	10	6.8	10	3,350	10	40	10
SW-K	409	20%	11	0.8	11	8.2	11	2,681	11	44	11
SW-L	299	16%	12	0.8	12	4.8	12	2,153	12	48	12
SW-M	230	7%	13	0.4	13	1.8	13	1,068	13	52	13

**Legend**

Cumulative Rank	3	SW-I	6	SW-D	9	SW-C	12	SW-L		Open Stream Channel	
1	SW-H	4	SW-B	7	SW-E	10	SW-A	13	SW-M		Subwatershed
2	SW-F	5	SW-G	8	SW-J	11	SW-K				



**Smith Branch Watershed Assessment**

Figure 5.1: Subwatershed Ranking















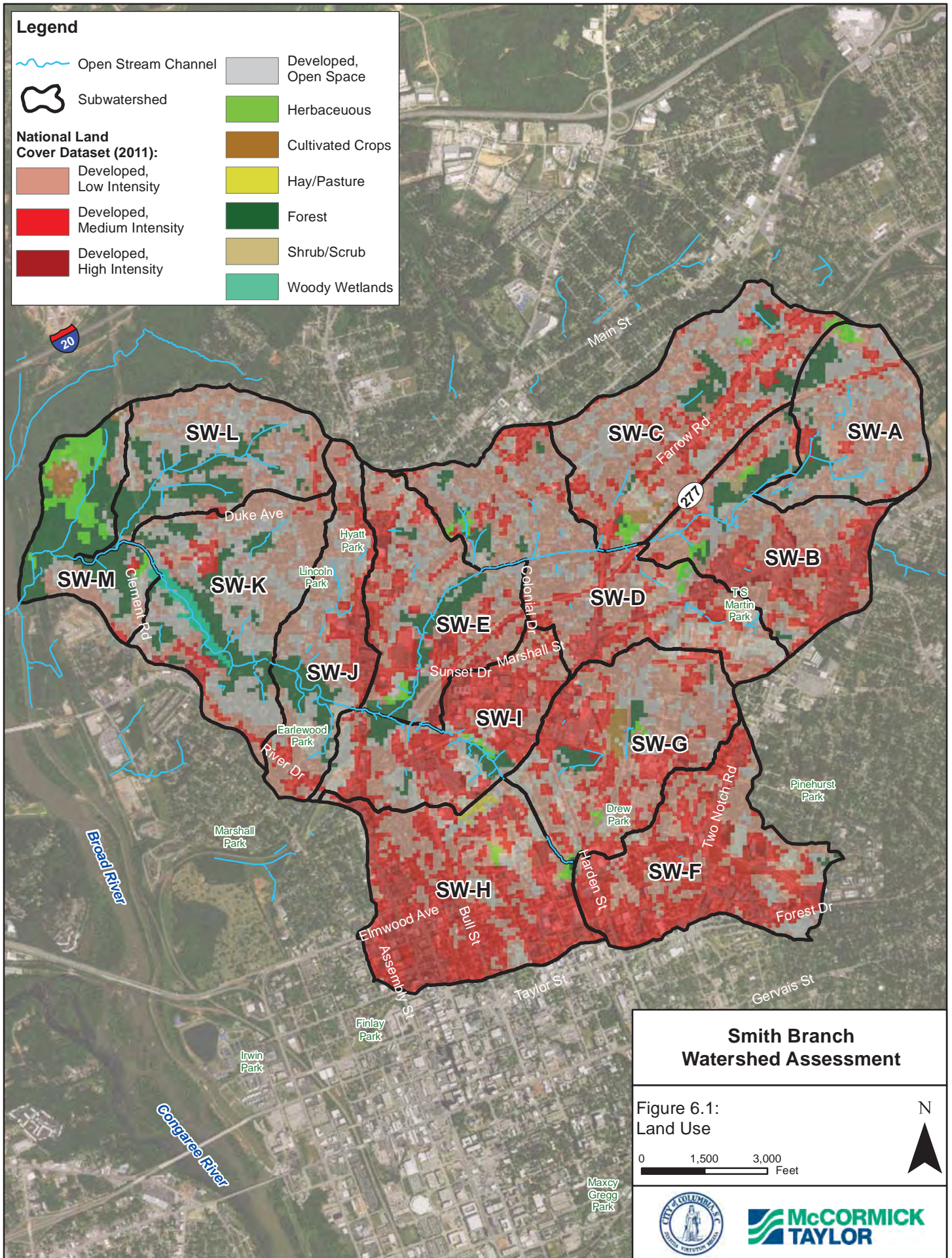


## 6.0 Detailed Subwatershed Assessment Results

The results of the existing conditions and preliminary restoration opportunities assessments are presented in this section. Each assessment is broken down by subwatershed and includes a general description of the location, land use, imperviousness and soils within each subwatershed. Also included in each assessment is a discussion on existing channel conditions and a SWM assessment of each subwatershed. Potential restoration opportunities have been identified based on the assessment of existing conditions. Each assessment contains descriptive graphics including: existing conditions, soils and restoration opportunities. **Figure 6.1** and **Table 6.1** highlight land use data for the all subwatersheds and are referenced in each subwatershed assessment.

**Legend**

-  Open Stream Channel
-  Subwatershed
- National Land Cover Dataset (2011):**
-  Developed, Low Intensity
-  Developed, Medium Intensity
-  Developed, High Intensity
-  Developed, Open Space
-  Herbaceous
-  Cultivated Crops
-  Hay/Pasture
-  Forest
-  Shrub/Scrub
-  Woody Wetlands



**Smith Branch  
Watershed Assessment**

Figure 6.1:  
Land Use

0 1,500 3,000  
Feet

N



Maxcy  
Gregg  
Park



Table 6.1 Subwatershed Land Use

Land Use	SW-A		SW-B		SW-C		SW-D		SW-E		SW-F		SW-G		SW-H		SW-I		SW-J		SW-K		SW-L		SW-M		Total			
	Acres	%	Acres	%	Acres	%	Acres	%	Acres	%	Acres	%	Acres	%	Acres	%	Acres	%	Acres	%	Acres	%	Acres	%	Acres	%	Acres	%		
Developed, Low Intensity	127.76	47%	144.73	39%	207.32	45%	264.89	52%	138.75	41%	110.96	28%	186.12	46%	100.01	22%	72.90	24%	113.70	40%	139.92	34%	109.69	37%	32.47	14%	1749.21	37%		
Developed, Medium Intensity	17.86	7%	71.37	19%	104.54	23%	95.56	19%	84.33	25%	194.87	49%	113.55	28%	202.92	44%	116.34	38%	46.52	16%	25.73	6%	5.33	2%	3.67	2%	1082.60	23%		
Developed, High Intensity	0.92	0%	75.53	20%	1.78	0%	21.55	4%	23.34	7%	60.68	15%	18.67	5%	118.09	25%	50.46	16%	20.24	7%	4.17	1%	0.00	0%	0.00	0%	395.43	8%		
Developed, Open Space	94.06	35%	43.15	12%	107.72	23%	101.77	20%	52.05	15%	31.50	8%	58.94	15%	32.35	7%	46.09	15%	71.94	25%	148.72	36%	103.82	35%	31.81	14%	923.92	19%		
Herbaceous	3.99	1%	4.40	1%	7.65	2%	7.68	2%	3.72	1%	0.04	0%	3.77	1%	4.43	1%	2.67	1%	0.00	0%	0.01	0%	0.00	0%	0.00	0%	44.62	19%	82.95	2%
Forest	25.90	10%	26.65	7%	29.09	6%	14.35	3%	40.09	12%	2.08	1%	14.65	4%	0.45	0%	20.55	7%	32.92	12%	71.55	17%	78.92	26%	104.80	45%	462.00	10%		
Shrub/Scrub	2.00	1%	2.89	1%	0.00	0%	0.00	0%	0.00	0%	0.00	0%	0.00	0%	0.00	0%	0.00	0%	0.00	0%	0.00	0%	0.00	0%	1.33	0%	0.00	0%	6.23	0%
Woody Wetlands	0.00	0%	0.00	0%	0.00	0%	0.00	0%	0.00	0%	0.00	0%	0.00	0%	0.00	0%	0.00	0%	0.00	0%	19.35	5%	0.00	0%	1.57	1%	20.91	0%		
Hay/Pasture	0.00	0%	0.00	0%	0.00	0%	0.00	0%	0.00	0%	0.00	0%	0.00	0%	5.46	1%	0.10	0%	0.00	0%	0.00	0%	0.00	0%	0.00	0%	0.00	0%	5.56	0%
Cultivated Crops	0.00	0%	0.00	0%	4.89	1%	0.00	0%	0.00	0%	0.00	0%	8.68	2%	0.00	0%	0.00	0%	0.00	0%	0.00	0%	0.00	0%	0.16	0%	11.23	5%	24.96	1%
Open Water	0	0%	0.00	0%	0.00	0%	0.00	0%	0.00	0%	0.00	0%	0.00	0%	0.00	0%	0.00	0%	0.00	0%	0.00	0%	0.00	0%	0.00	0%	0.20	0%	0.20	0%
<b>Total</b>	<b>272.50</b>	<b>100%</b>	<b>368.73</b>	<b>100%</b>	<b>462.99</b>	<b>100%</b>	<b>505.79</b>	<b>100%</b>	<b>342.28</b>	<b>100%</b>	<b>400.11</b>	<b>100%</b>	<b>404.38</b>	<b>100%</b>	<b>463.70</b>	<b>100%</b>	<b>309.12</b>	<b>100%</b>	<b>285.32</b>	<b>100%</b>	<b>409.45</b>	<b>100%</b>	<b>299.25</b>	<b>100%</b>	<b>230.37</b>	<b>100%</b>	<b>4753.98</b>	<b>100%</b>		

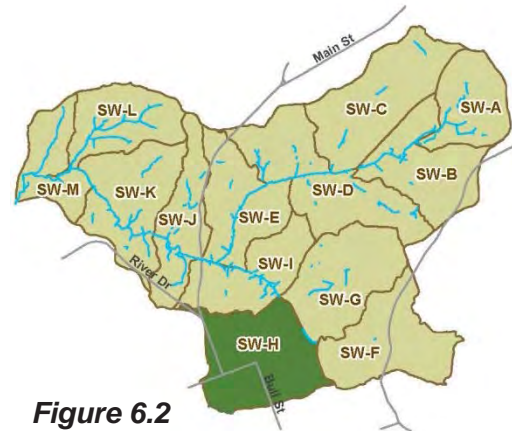


## 6.1 Subwatershed H (SW-H)

### Introduction

#### Setting:

- Subwatershed H (SW-H) is the southwestern-most subwatershed within the Smith Branch watershed.
- The northernmost boundary crosses River Drive and Bull Street/SC-277, the eastern boundary runs parallel and to the east of Gregg Street, Blanding Street to the south, and the western boundary is west of Main Street.
- 464 acres or 0.73 square miles in drainage area
- SW-H contains no open stream channel, and 10.60 miles of mapped storm drain/pipe
- Dominant land use designations (**Figure 6.1, Table 6.1**):
  - Developed, Medium Intensity: 44%
  - Developed, High Intensity: 25%
  - Developed, Low Intensity: 22%
- Impervious surface cover: 59%



**Figure 6.2**  
**Subwatershed H**

**Soils:** Approximate soil type percentages within SW-H include (refer to **Section 3.4** for soil descriptions and **Figure 6.3** for soil distributions):

- Urban land (Ur): 64%
- Orangeburg-Urban land complex, 2 to 6% slopes (OgB): 20%
- Pelion-Urban land complex, 2 to 10% slopes (PnC): 14%
- Orangeburg-Urban land complex, 6 to 15% slopes (OgD): 2%
- Johnston loam (Jo): <1%




#### Overview:

SW-H is highly developed and primarily commercial; however, there are pockets of single-family detached homes and community buildings throughout the subwatershed. Residential lots are landscaped and street trees are mature. Buildings with the large footprints include the the South Carolina Department of Mental Health complex and multiple commercial buildings along Assembly Street.

### Existing Conditions

**Figure 6.4** highlights existing conditions that were either captured during the stream cruising effort or developed using GIS data.

**Legend**

-  Open Stream Channel
-  Soils
-  Subwatershed



**Legend**

- Trash Dumping
- Unusual Condition
- Inadequate Forest Buffer
- Pipe Outfall
- ~ Open Stream Channel
- SWM Facility
- Possible Fish Barrier
- Erosion Site
- SWMM Subcatchment
- Exposed Pipe
- Channel Alteration
- Subwatershed
- Unmanaged Runoff





Existing Condition	Count
Exposed Pipes	0
Pipe Outfalls	0
Unmanaged Runoff	0
Unusual Condition	0
Trash Dumping	0
Possible Fish Barrier	0
	<b>Linear Feet</b>
Erosion Site	0
Channel Alteration	0
Inadequate Forest Buffer	0

**Smith Branch  
Watershed Assessment**

Figure 6.4:  
Subwatershed H  
Existing Conditions

N  
▲

0 600 1,200  
Feet



**Channel Conditions:**

There are no mapped or observed open stream channels in SW-H.

**Constraints:**

- Property Ownership:
  - Overall SW-H Open Channel:
    - Public: N/A
    - Private: N/A
  - Within a 50 Foot Wide Open Channel Buffer:
    - Public: N/A
    - Private: N/A
- Mapped Drainage Network:
  - Drain Pipe: 100%
  - Open Stream Channel: 0%

**SWM Assessment:**

*Facilities*

There are no mapped stormwater facilities within SW-H.

*Outfalls*

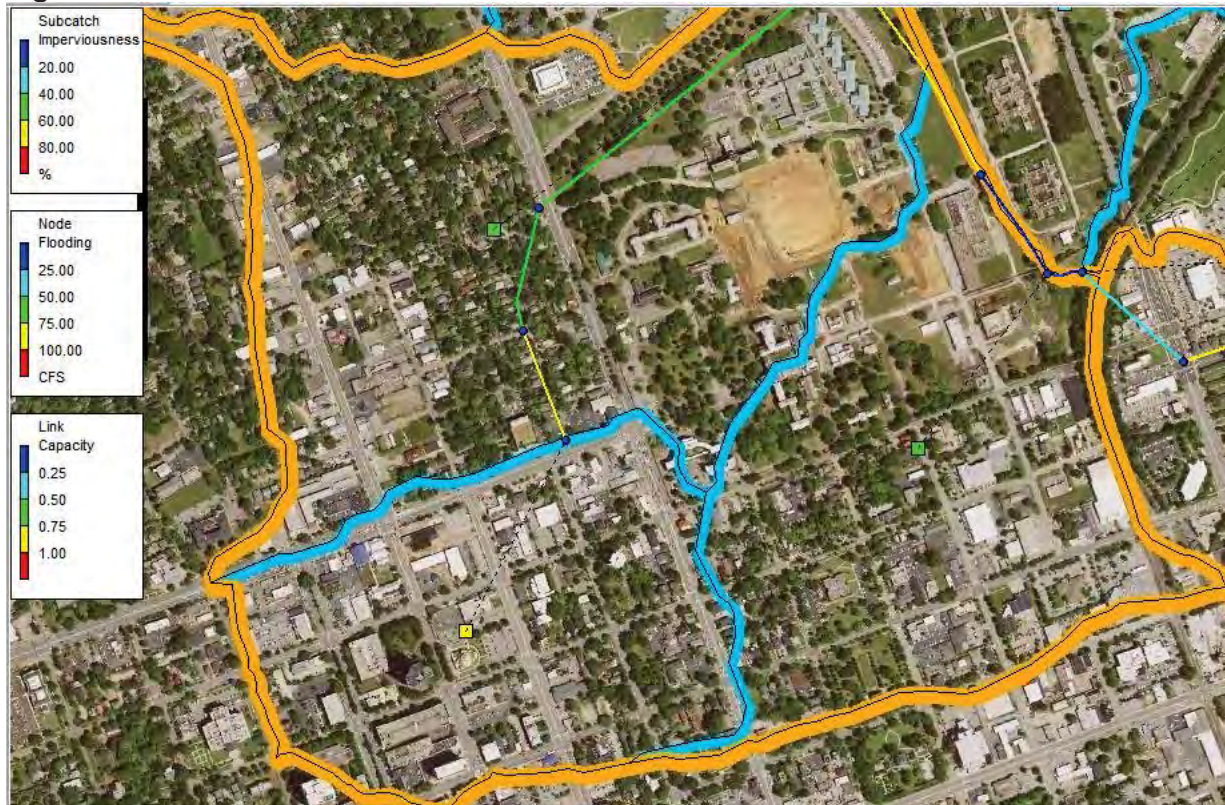
There are no mapped outfalls within SW-H.

*SWMM*

SW-H is in the southwest corner the watershed and borders the Rocky Branch Watershed to the south. SW-H comprised of 464 acres with 59% impervious surface, the highest impervious within the watershed. The results from the 2-year storm event in SWMM predict 1.3 peak cfs/acre and 26.1 million gallons of runoff, the latter of which is the highest for any subwatershed. The runoff per area is also the highest within the watershed at 7,521 cubic feet/acre. Because of these results, SW-H has the highest ranking for Smith Branch, indicating it is in need of drainage improvements.

SW-H is modeled as three subcatchments in SWMM, as shown in **Figure 6.5**. It is greater than 75% impervious in the southwestern catchment. According to the model, SW-H produces the most runoff per acre, and this runoff flows via concrete pipes directly to the headwaters of Smith Branch above Colonial Drive.

**Total Subwatershed Runoff Ranking: 1**

**Figure 6.5 SW-H SWMM Model**








### Restoration Opportunities

The following projects or similar improvements may be considered to address conditions identified in SW-H. These projects are included in **Figure 6.6**.

#### **Recommended Improvements:**

- Opportunities for infiltration and storage should be investigated to reduce peaks downstream. Due to its location at the headwaters of Smith Branch, and on the edge of the watershed adjacent to the Rocky Branch Watershed, this area has the most potential to affect flows downstream.
  - Plant trees where feasible on the South Carolina Mental Health facility campus
  - Apply the green streets template to reduce runoff for Sumter and Main Streets.
- Daylighting and stream restoration of the piped segment south of Colonial Drive and north of Calhoun Street within the Bull Street Redevelopment to provide infiltration and peak reduction.
- As this catchment continues to develop, the development should occur in accordance with the City of Columbia BMP Manual, particularly Sections 1.2.1 and 1.2.3

**Legend**

-  Infrastructure Improvements
-  Low Impact Development
-  Reforestation/Buffer Establishment
-  Stormwater Management
-  Stream Restoration
-  Open Stream Channel
-  Subwatershed



**Smith Branch  
Watershed Assessment**

Figure 6.6:  
Subwatershed H  
Restoration Opportunities

0 600 1,200  
Feet

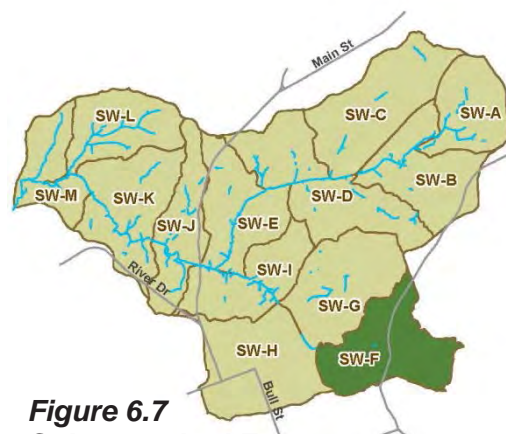


## 6.2 Subwatershed F (SW-F)

### Introduction

#### Setting:

- Subwatershed F (SW-F) is the southeastern-most subwatershed within the Smith Branch watershed.
- SW-F boundaries are roughly Taylor Street to the south, Harden Street to the west, Harrison Road to the north, and Devonshire Drive to the east.
- 400 acres or 0.63 square miles in drainage area
- Contains 0.20 miles of open stream channel, and 4.42 miles of mapped storm drain/pipe
- Dominant land use designations (**Figure 6.1, Table 6.1**):
  - Developed, Medium Intensity: 49%
  - Developed, Low Intensity: 28%
- Impervious surface cover: 54%



**Figure 6.7**  
**Subwatershed F**

**Soils:** Approximate soil type percentages within SW-F include (refer to **Section 3.4** for soil descriptions and **Figure 6.8** for soil distributions):

- Urban land (Ur): 56%
- Pelion-Urban land complex, 2 to 10% slopes (PnC): 36%
- Rains sandy loam (Ra): 6%
- Dothan-Urban land complex, 0 to 6% slopes (DuB): 2%
- Vaucluse loamy sand, 10 to 15% slopes (VaD): <1%




#### Overview:

SW-F is diverse in its land use designations and it is one of the more urbanized subwatersheds. SW-F is home to Benedict College, Charlie W. Johnson Stadium, Carver-Lyon Elementary School, and Providence Hospital, all of which have large footprints. Commercial corridors along Two Notch Road and Harden Street also give way to large impervious areas. A mix of single-family attached and detached residences as well as multi-family apartment buildings are throughout the subwatershed. The largest open space in SW-F is associated with the Benedict College Charlie W. Johnson Stadium and joining sports facilities.

### Existing Conditions

**Figure 6.9** highlights existing conditions that were either captured during the stream cruising effort or developed using GIS data.

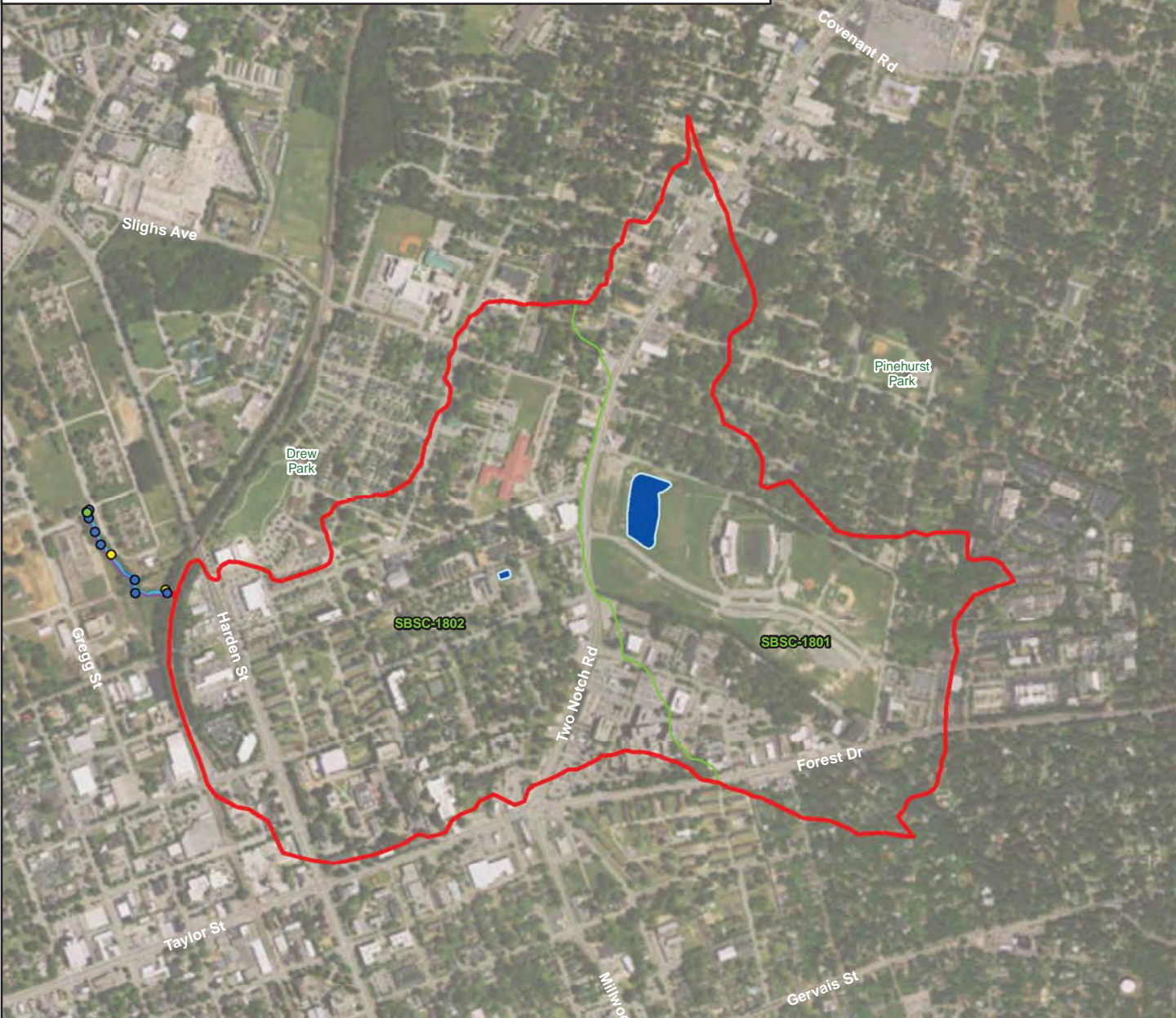
**Legend**

-  Open Stream Channel
-  Soils
-  Subwatershed



**Legend**

- Trash Dumping
- Unusual Condition
- Inadequate Forest Buffer
- Pipe Outfall
- ~ Open Stream Channel
- SWM Facility
- Possible Fish Barrier
- Erosion Site
- SWMM Subcatchment
- Exposed Pipe
- Channel Alteration
- Subwatershed
- Unmanaged Runoff



Existing Condition	Count
Exposed Pipes	0
Pipe Outfalls	8
Unmanaged Runoff	0
Unusual Condition	3
Trash Dumping	0
Possible Fish Barrier	1
Linear Feet	
Erosion Site	0
Channel Alteration	79
Inadequate Forest Buffer	1,909

**Smith Branch  
Watershed Assessment**

Figure 6.9:  
Subwatershed F  
Existing Conditions



Dr Martin Luther King Jr Park



### Channel Conditions:



SW-F drains to a segment of open stream channel extending along the SW-H and SW-G boundary to the west. The upstream limit of open channel originates from a 52 inch concrete outfall under the railroad behind Andrews Auto Service (west of Harden Street and north of Calhoun Street). Expansion scour has likely contributed to widening and there is a large scour pool downstream of the outfall. Downstream, an abandoned degraded railroad bridge constricts the channel, and creates a pinch point. Stream banks are approximately 7-feet tall and are vegetated and stable.

Large coarse deposits define channel baseflow throughout this segment. Substrate within the stream bed is mainly sand, with gravel and cobble along the riffles. The stream enters a pipe at Preston Drive. Currently, the City of Columbia is restoring this stream segment and daylighting the piped segment extending downstream through the Bull Street Redevelopment Project.

#### *Ecology*

The segment of stream that SW-F drains to has fair stream habitat quality. A narrow riparian buffer and sedimentation are the main impairments. The channel segment within SW-F has less than a 35 foot vegetated riparian buffer.

### Constraints:

- Property Ownership:
  - Overall SW-F Open Channel:
    - Public: 93%
    - Private: 7%
  - Within a 50 Foot Wide Open Channel Buffer:
    - Public: 89%
    - Private: 11%
- Mapped Drainage Network:
  - Drain Pipe: 96%
  - Open Stream Channel: 4%
- There are no longitudinal channel interruptions
- Channel encroachment: railroad

### SWM Assessment:

#### *Facilities*

There are two mapped stormwater facilities in SW-F. The first is to the north of Providence Hospital, adjacent to the Charlie W. Johnson Stadium. The second is at the Read Street and Waverly Street intersection.

#### *Outfalls*

During the field review, a total of eight stormwater outfalls were identified within this subwatershed, all of which rated minor to moderate severity.



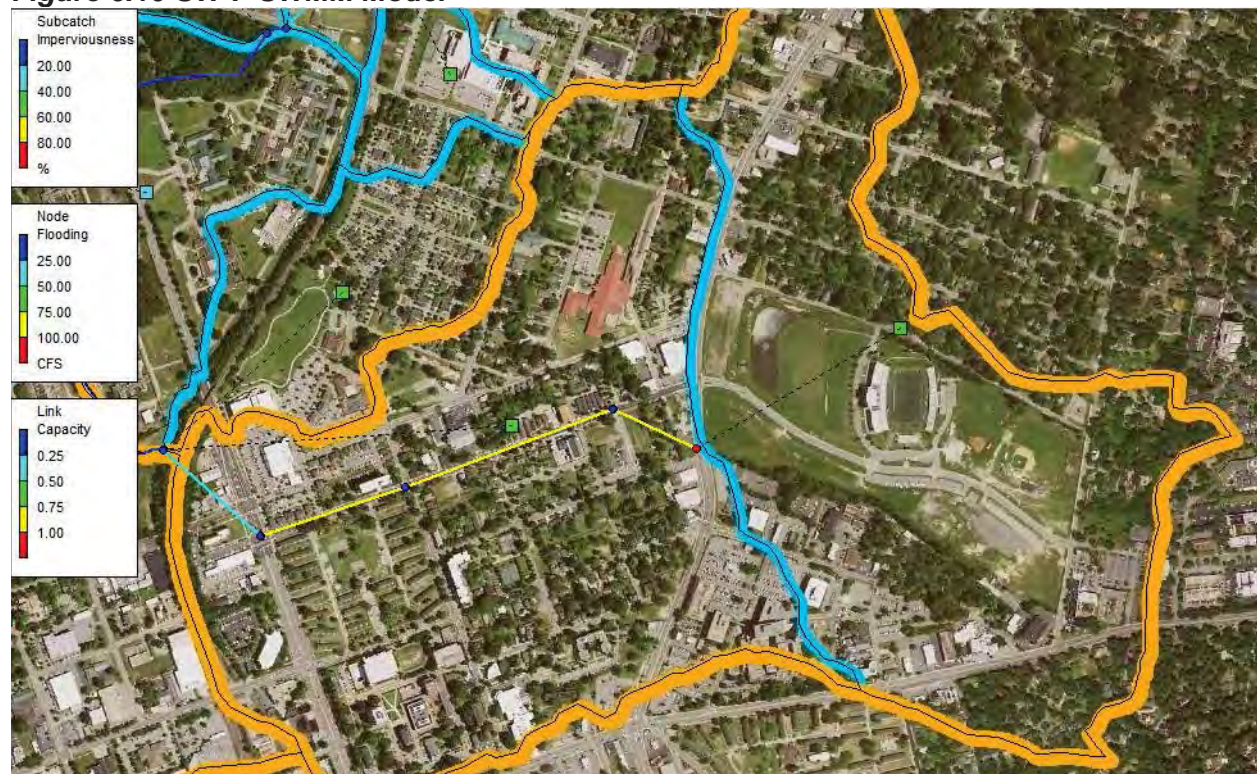
*SWMM*

SW-F is in the southeastern corner of the watershed and has the second highest amount of impervious surface at 54%. SW-F is 400 acres, and the SWMM model predicts for a 2-year storm event that the area will produce 20.9 million gallons of runoff, which is the second highest in the watershed. The runoff per area is also the second largest in the watershed at 6,970 cubic feet/acre. The discharge per acre for a 2-year storm event is modeled at 1.4 peak cfs/acre, the third highest amount within Smith Branch. SW-F received the second highest overall runoff ranking. SW-F borders the Martin Luther King and Gregg Street highly impervious subwatersheds from the Rocky Branch Watershed, and efforts to improve this area as a whole are highly recommended.

SW-F is modeled as two subcatchments in SWMM. Concentrations of impervious commercial area can be seen at the downstream end of the watershed. The subcatchments are 58% and 48% impervious, respectively, and there is a main pipe conduit that drains both of the subcatchments that is modeled at greater than 75% capacity for the 2-year event (see mapped yellow line in **Figure 6.10**). SW-F sends flows directly to the large culverts below Preston Drive.

**Total Subwatershed Runoff Ranking: 2**

**Figure 6.10 SW-F SWMM Model**












### **Restoration Opportunities**

The following projects or similar improvements may be considered to address conditions identified in SW-F. These projects are included in **Figure 6.11**.

#### **Recommended Improvements:**

- Opportunities for infiltration and storage should be investigated here to reduce peaks downstream.
  - Plant trees where feasible in the Benedict College Athletic Facility, Carver-Lyon Elementary School, Allen Benedict Court Complex and east of the Gordon Street and Waites Road intersection.
  - Install BMPs for parking lot at Providence Hospital, Carver Lyon Elementary School, and Benedict College.
  - Apply green streets template to reduce runoff at Allen Benedict Court, Benedict College and at the development east of Benedict College.
- As this catchment continues to develop, the development should occur in accordance with the City of Columbia BMP Manual, particularly Sections 1.2.1 and 1.2.3.
- Further division and modeling of these catchments will help to locate the areas with the most constrained infrastructure and areas where improvements will yield the most benefit.

**Legend**

-  Infrastructure Improvements
-  Low Impact Development
-  Reforestation/Buffer Establishment
-  Stormwater Management
-  Stream Restoration
-  Open Stream Channel
-  Subwatershed



**Smith Branch  
Watershed Assessment**

Figure 6.11:  
Subwatershed F  
Restoration Opportunities

0 600 1,200  
Feet



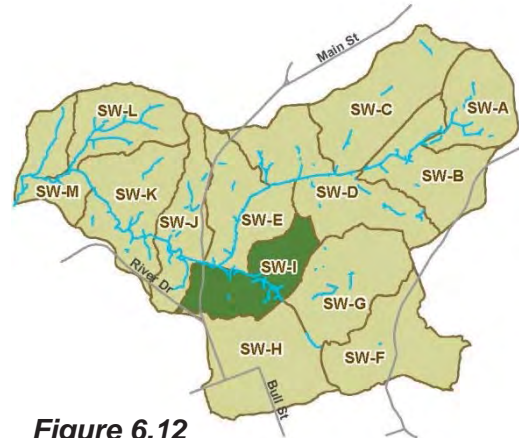
Dr Martin  
Luther King  
Jr Park

## 6.3 Subwatershed I (SW-I)

### Introduction

#### Setting:

- Subwatershed I (SW-I) is within the south central portion of the Smith Branch watershed.
- The eastern boundary of SW-I runs along Colonial Drive/Farrow Road, extends north towards SC-277, then south around the Palmetto Health - Richland Medical Park, west to Earlewood Park, then south to River Drive.
- 309 acres or 0.48 square miles in drainage area
- Contains 1.5 miles of open stream channel, and 4.0 miles of mapped storm drain/pipe
- Dominant land use designations (**Figure 6.1, Table 6.1**):
  - Developed, Medium Intensity: 38%
  - Developed, Low Intensity: 24%
- Impervious surface cover: 47%



**Figure 6.12**  
**Subwatershed I**

**Soils:** Approximate soil type percentages within SW-I include (refer to **Section 3.4** for soil descriptions and **Figure 6.13** for soil distributions):

- Pelion-Urban land complex, 2 to 10% slopes (PnC): 29%
- Orangeburg-Urban land complex, 2 to 6% slopes (OgB): 25%
- Orangeburg-Urban land complex, 6 to 15% slopes (OgD): 17%
- Johnston loam (Jo): 12%
- Fuquay-Urban land complex, 0 to 6% slopes (FyB): 9%
- Urban land (Ur): 5%
- Vacluse loamy sand, 6 to 10% slopes (VaC): 4%




#### Overview:

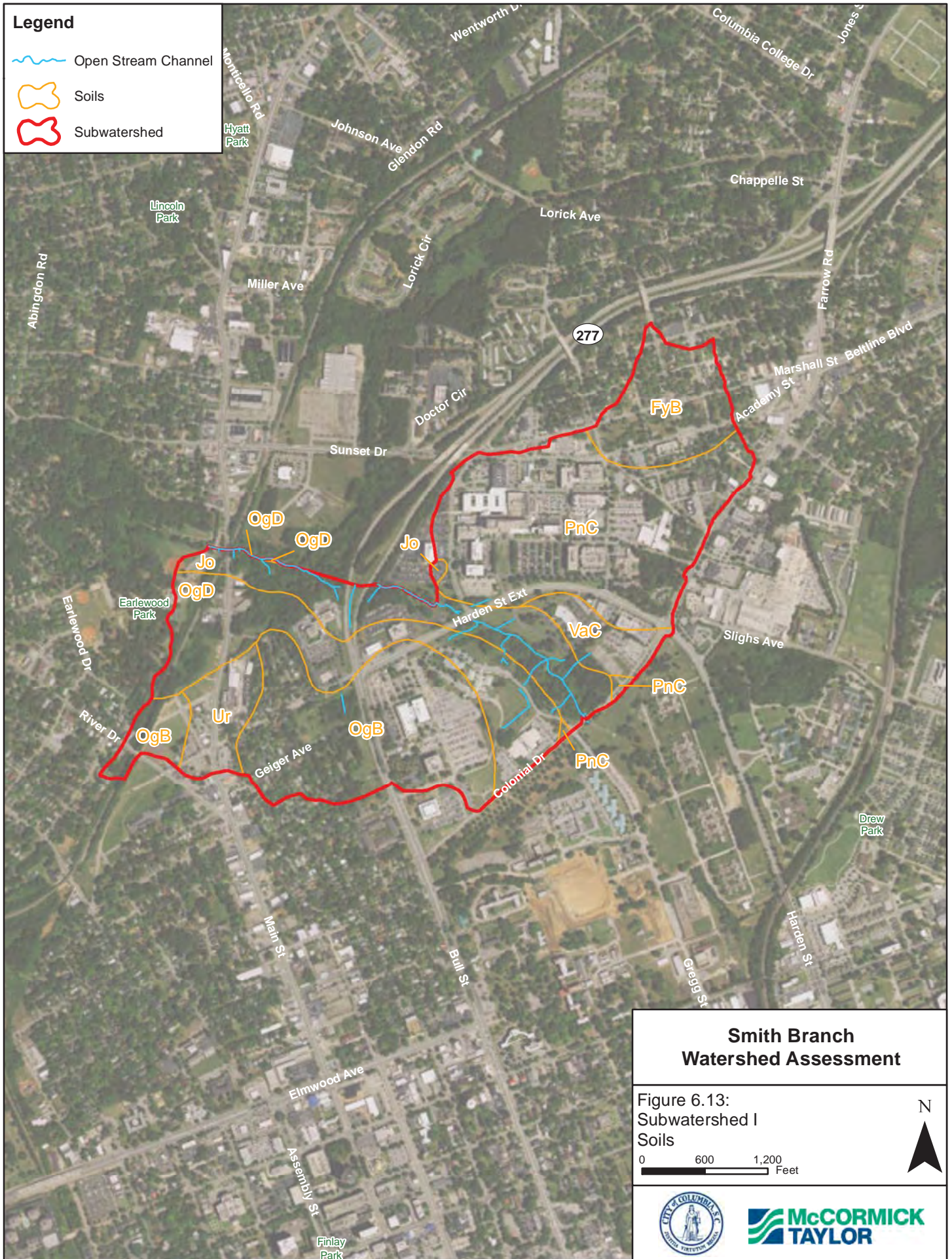
The majority of the east-central portion of the subwatershed consists of the Palmetto Health - Richland Medical Park. The hospital has a large footprint and includes multiple buildings, all with large parking facilities. South of Harden Street Extension is the DHEC and other large government buildings. There are also numerous commercial buildings along Bull Street and Main Street.

### Existing Conditions

**Figure 6.14** highlights existing conditions that were either captured during the stream cruising effort or developed using GIS data.

**Legend**

-  Open Stream Channel
-  Soils
-  Subwatershed



**Smith Branch  
Watershed Assessment**

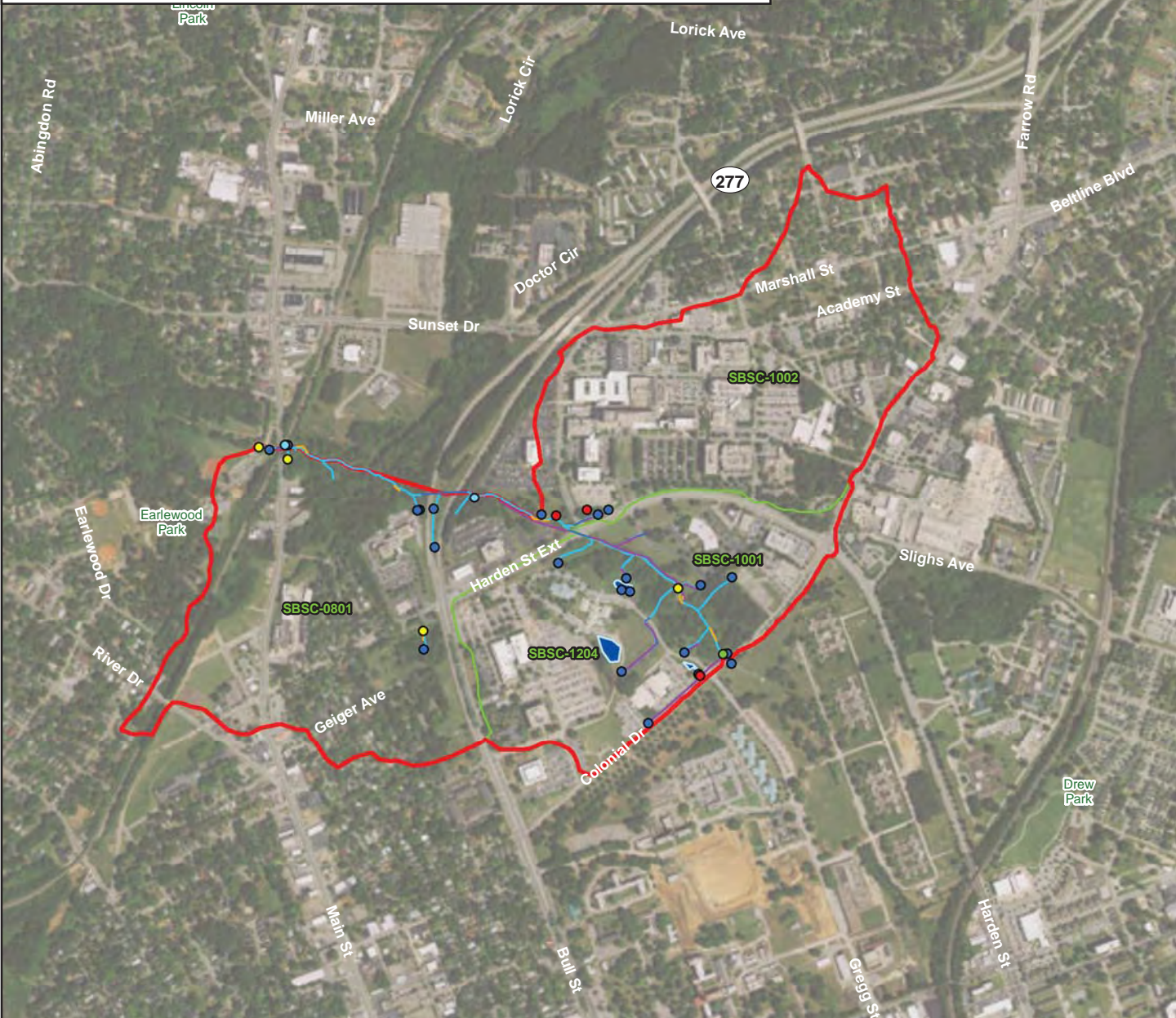
Figure 6.13:  
Subwatershed I  
Soils

0 600 1,200  
Feet



**Legend**

- Trash Dumping
- Unusual Condition
- Inadequate Forest Buffer
- Pipe Outfall
- ~ Open Stream Channel
- SWM Facility
- Possible Fish Barrier
- Erosion Site
- SWMM Subcatchment
- Exposed Pipe
- Channel Alteration
- Subwatershed
- Unmanaged Runoff



Existing Condition	Count
Exposed Pipes	2
Pipe Outfalls	22
Unmanaged Runoff	3
Unusual Condition	4
Trash Dumping	0
Possible Fish Barrier	1
	<b>Linear Feet</b>
Erosion Site	664
Channel Alteration	885
Inadequate Forest Buffer	6,795

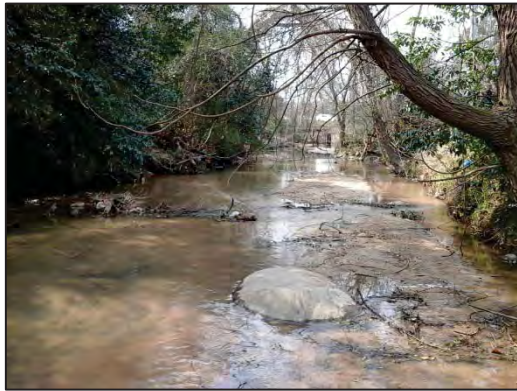
**Smith Branch  
Watershed Assessment**

Figure 6.14:  
Subwatershed I  
Existing Conditions





**Channel Conditions:**



Within SW-I, the upstream extent of the mainstem of Smith Branch flows from a 10 foot wide by 10 foot tall double box culvert beneath Colonial Drive. There is a 30 inch baseflow water surface drop off at the end of the culvert apron and a deep scour pool immediately downstream. The floodplain and top of bank is heavily vegetated with thick underbrush and the 12-foot banks are relatively stable, with isolated areas of erosion. A beaver dam creates a significant backwater 650 feet downstream of the Colonial Drive culvert. Downstream of the beaver dam, the stream is shallow, with depositional midchannel and point bars. Substrate within this segment of stream is predominantly sand, with gravel, cobble, and boulder along the riffles. Riprap stabilizes the right bank and thick vegetation covers the left bank face as Smith Branch approaches the Harden Street Extension.

There are seven small tributaries that flow into the mainstem south (upstream) of the Harden Street Extension. Most were contributing little to no flow during the stream cruising effort. Four originate within the DHEC complex, west of the mainstem, three of which are outfalls associated with nearby stormwater facilities. The most significant tributary begins at an outfall adjacent to parking lots of the DHEC and the SC Department of Social Services buildings and may be connected to an existing stormwater facility but City GIS storm drains are discontinuous in this area. The outfall closest to the Harden Street Extension on the southwest side discharges into a wet swale with thick shrub growth and joins the mainstem from the left bank. East of the mainstem, one outfall with no recent evidence of discharge originates from the Child Support Enforcement building parking lot. The remaining two outfalls drain from the SC Department of Disabilities and Special Needs (DDSN) building entrance road and parking lot.

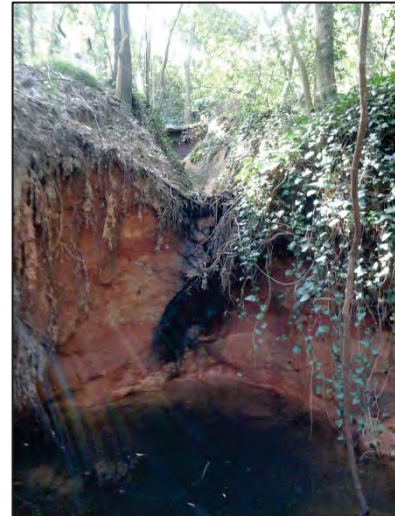


The Smith Branch mainstem flows west through the double box culvert underneath the Harden Street Extension. Infrastructure encroachment, excessive sediment deposition, and poor buffer management practices (mowed to top of bank) have resulted in bank instability and observed block failures extending 150 feet along the left bank, downstream (north) of the Harden Street Extension. Downstream, the banks are more heavily vegetated and stable. Two small tributaries contribute flow into this mainstem segment. The upstream tributary runs parallel to the Harden



Street Extension, extending under Medical Park Road to join the mainstem. The second is a small seep parallel to SC-277. The Smith Branch mainstem flows through a 11.5 foot wide and 11.5 foot tall double box culvert under SC-277.

Immediately downstream of the SC-277 culvert, a segmented tributary drains into the mainstem. The upstream extent of this tributary begins northeast of Geiger Avenue at an 18 inch RCP outfall. A 20-foot tall headcut has formed downstream of the outfall, scouring the banks. The stream is open channel for 160 feet before being piped approximately 930 feet downstream, emerging from a 52 inch CMP and flowing into the mainstem. Multiple branches of mapped storm drain connect into this tributary, explaining the increased size of outfall at the downstream end. Instability was noted at the 52 inch CMP outfall and is discussed further below.



Downstream of SC-277, the Smith Branch mainstem flows through a forested parcel, with vegetated, stable banks and large points bars. Bay Branch joins the mainstem 260 feet downstream of the SC-277 culvert. Bank erosion and lateral migration threatens a utility right of way and manhole stack upstream of Main Street. The stream then flows through a 12 foot tall, 16 foot wide culvert under Main Street. Downstream of Main Street, Smith Branch enters Earlewood Park and is confined within brick and mortar walls for 70 feet, extending to the downstream side of the Parkside Drive bridge. The downstream boundary of SW-I crosses the mainstem at this point and Smith Branch continues to flow downstream through SW-J.

### *Ecology*

The stream habitat quality in SW-I is generally poor upstream of SC-277, and improves downstream of SC-277. The mainstem segment adjacent to DHEC is impacted by heavy sedimentation, lack of epifaunal substrate/available cover, and past channel alteration. The channel segment that flows through the Richland Memorial Hospital grounds has similar issues, with the addition of poor bank stability and little vegetative protection upstream. Downstream of SC-277, the floodplain is less developed and vegetation is better established, banks are more stable, and there is less channel alteration, though heavy sedimentation is still apparent. The majority of the stream network has an adequate riparian buffer (approximately 65%), with the exception of portions of the upstream and middle segments where the riparian buffer has been mowed.

### **Constraints:**

- Property Ownership:
  - Overall SW-I Open Channel:
    - Public: 29%
    - Private: 71%
  - Within a 50 Foot Wide Open Channel Buffer:
    - Public: 73%
    - Private: 27%



- Mapped Drainage Network:
  - Drain Pipe: 73%
  - Open Stream Channel: 27%
- Seven longitudinal channel interruptions
- Channel encroachment: utility lines, road crossings

### **SWM Assessment:**

#### *Facilities*

Three stormwater facilities are mapped in SW-I, all three are located between the Harden Street Extension and Colonial Drive.

#### *Outfalls*

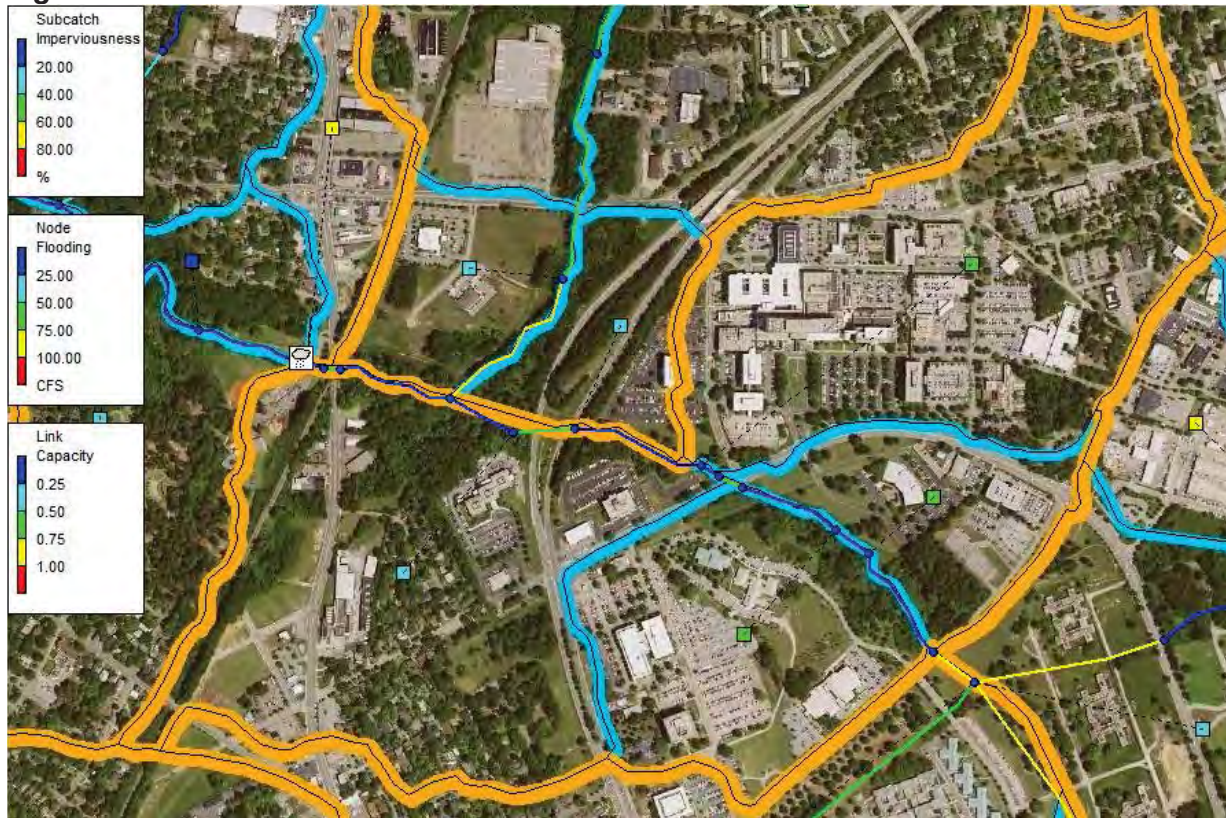
During the stream cruising effort, a total of 22 stormwater outfalls were identified within SW-I, all of which are in minor to moderate condition with the exception of three. The outfall northeast of Geiger Avenue is in very severe condition; an extreme headcut was noted in the channel downstream creating a 20 foot drop and the concrete pad at the pipe outfall is being undercut. The two other outfalls, in severe condition, are adjacent to one another, located southwest of the Smith Branch mainstem SC-277 crossing. The headwall and concrete pad have been severely undercut, compromising the structural integrity.

#### *SWMM*

SW-I is medium-sized relative to the other subwatersheds at 309 acres and occupies the southcentral portion of the Smith Branch Watershed. The SWMM model predicts that SW-I would produce 1.4 peak cfs/acre for a 2-year storm event, which is the second highest in the watershed. This value is related in part to the higher than average impervious surface value of 47%. SW-I is modeled to produce 14.1 million gallons of runoff during a 2-year storm event, which is the sixth highest amount within the watershed. The runoff per area is third highest among the 13 subwatersheds at 6,115 cubic feet/acre. SW-I is the third highest-ranking overall within the watershed based on runoff components.

SW-I is modeled as four subcatchments in SWMM that contribute flows directly to Smith Branch. The culvert crossings along Smith Branch can be seen as the green links in the model (**Figure 6.15**), meaning they have reached at least 50% capacity for the 2-year event. The arch culvert at Main Street, near the City's stream and rain gage SWIA, is recommended for upgrade.

### **Total Subwatershed Runoff Ranking: 3**

**Figure 6.15 SW-I SWMM Model**

### **Restoration Opportunities**

The following projects or similar improvements may be considered to address conditions identified in SW-I. These projects are included in **Figure 6.16**.

### **Recommended Improvements:**

- The bridge at Main Street over Smith Branch should be improved to dual 12' x 12' culverts. Currently it is creating a backwater condition during a 2-year storm event.
- As this catchment continues to develop, the development should occur in accordance with the City of Columbia BMP Manual, particularly Sections 1.2.1 and 1.2.3.
- Development in flood-prone areas near Smith Branch should be restricted. In addition, open space floodplains where Smith Branch flows through this catchment should be investigated for permanent protection under easements or restrictive covenants.
- Methods for disconnecting and reducing the large impervious areas should be investigated.
- Stabilize the outfalls southwest of the mainstem culvert under SC-277 and north of Geiger Avenue. Stabilize the headcut downstream of the outfall at Geiger Avenue.
- Opportunities for infiltration and storage should be investigated here to reduce peaks downstream.
  - Replace the concrete flume within the median in SC-277 with rock dissipation/step structure and bioswale or bioretention area.



- Restripe main parking lots for the Medical Park buildings, remove small detached parking lot closest to Harden Street Extension and provide BMPs for all parking lots draining into Smith Branch.
- Install outfall dissipation forebays to the DDSN complex on Harden Street Extension.
- Provide BMPs for the parking lots at the DHEC building, SC Child Support Enforcement building, the 801 Sunset Drive Clinics, and the Richland Memorial Hospital Complex.
- Plant trees where feasible around the DHEC building, the DDSN, the areas west of Bull Street and west of Main Street.
- Construct a shallow marsh or wet pond to treat runoff from parking garage at Medical Park Road and Harden Street Extension.
- For the outfall from the USC medical complex, relocate outfall away from Smith Branch to allow for treatment of storm drain flow and construction of a shallow marsh or wet pond.
- Retrofit the dry pond at the parking lot at Grand Street and Shealy Street to improve water quality and add storage.
- Construct bioretention area or bioswale at the entrance to the Palmetto Health-Richland Medical Park.
- Construct bioretention cells within parking islands of the Palmetto Health-Richland Medical Park parking lots.
- Stabilize the banks of Smith Branch mainstem west of Main Street.
- Reshape and stabilize the Smith Branch mainstem channel east of SC-277 and north of Harden Street Extension.
- Remove the beaver dam and stabilize the headcuts and bank erosion in the mainstem channel between Colonial Drive and Harden Street Extension.





## 6.4 Subwatershed B (SW-B)

### Introduction

#### Setting:

- Subwatershed B (SW-B) is located to the northeast within the Smith Branch watershed.
- SC-277 creates the westernmost boundary and the northernmost point of the subwatershed is at the SC-277 North and railroad overpass. The southernmost point in SW-B is within the Crescent Hill Cemetery. SW-B extends slightly east of Two Notch Road.
- 369 acres or 0.58 square miles in drainage area
- Contains 1.18 miles of open stream channel, and 1.46 miles of mapped storm drain/pipe
- Dominant land use designations (**Figure 6.1, Table 6.1**):
  - Developed, Low Intensity: 39%
  - Developed, High Intensity: 20%
  - Developed, Medium Intensity: 19%
- Impervious surface cover: 47%



**Figure 6.17**  
**Subwatershed B**

**Soils:** Approximate soil type percentages within SW-B include (refer to **Section 3.4** for soil descriptions and **Figure 6.18** for soil distributions):

- Pelion-Urban land complex, 2 to 10% slopes (PnC): 54%
- Urban land (Ur): 31%
- Fuquay-Urban land complex, 0 to 6% slopes (FyB): 10%
- Lakeland-Urban land complex, 2 to 6% slopes (LkB): 3%
- Johnston loam (Jo): 1%
- Rains sandy loam (Ra): 1%
- Vacluse loamy sand, 10 to 15% slopes (VaD): 1%




#### Overview:

The easternmost boundary of SW-B is highly commercialized. The corridor along Two Notch Road and Beltline Boulevard is an older development; roadways are undivided and generally narrow, and commercial properties are set back from the roadway with large frontal parking lots. The remainder of the subwatershed is residential. The railroad traverses north-south through the western portion of the subwatershed. To the east of this railroad are primarily single-family, detached homes and to the west of the railroad are multi-family homes and apartment buildings. The footprints of the multi-family and apartment buildings are large and they also have large parking facilities.

### Existing Conditions

**Figure 6.19** highlights existing conditions that were either captured during the stream cruising effort or developed using GIS data.

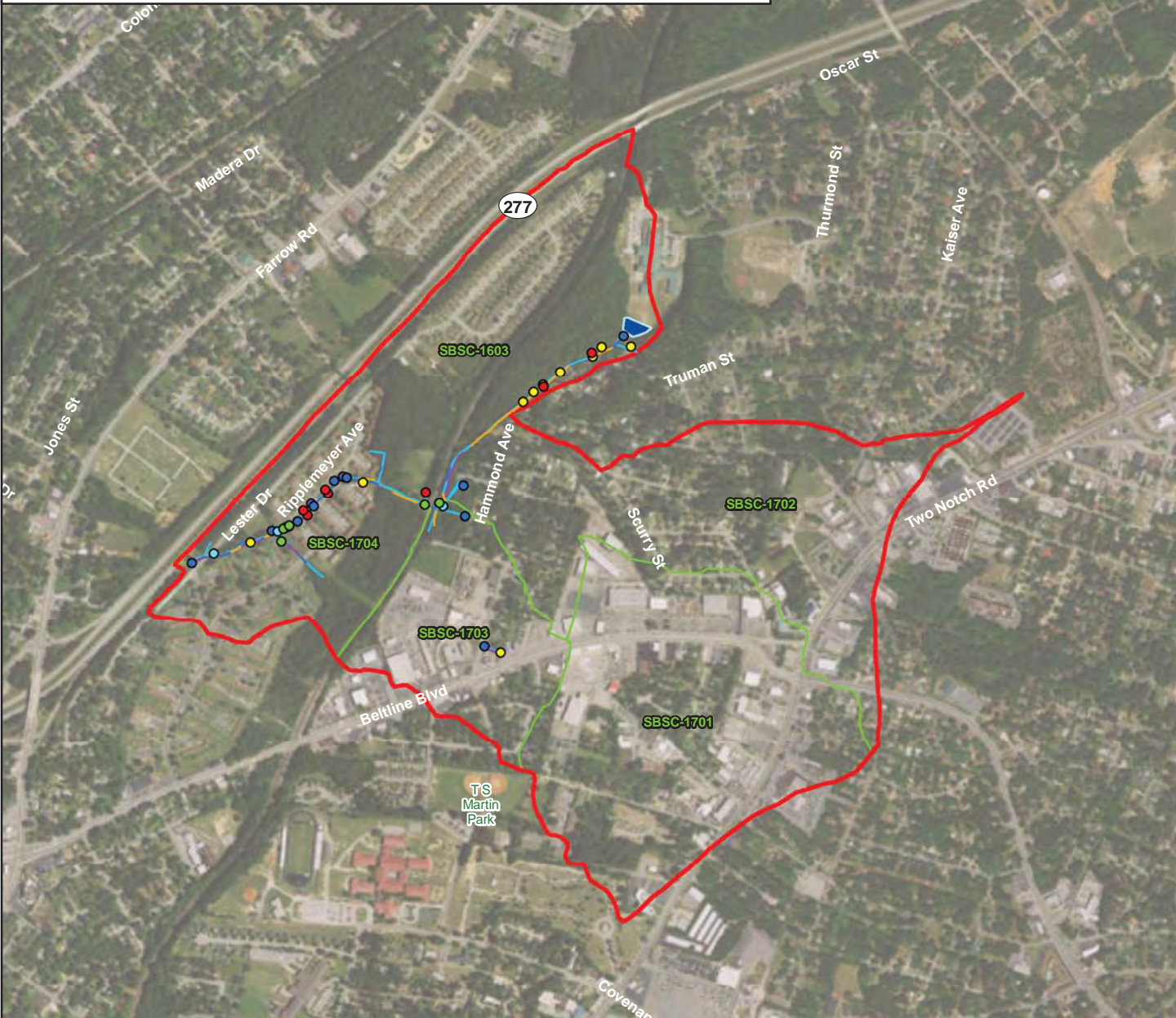
**Legend**

-  Open Stream Channel
-  Soils
-  Subwatershed



**Legend**

- Trash Dumping
- Unusual Condition
- Inadequate Forest Buffer
- Pipe Outfall
- Open Stream Channel
- SWM Facility
- Possible Fish Barrier
- Erosion Site
- SWMM Subcatchment
- Exposed Pipe
- Channel Alteration
- Subwatershed
- Unmanaged Runoff



Existing Condition	Count
Exposed Pipes	6
Pipe Outfalls	13
Unmanaged Runoff	7
Unusual Condition	11
Trash Dumping	0
Possible Fish Barrier	5
Linear Feet	
Erosion Site	2,241
Channel Alteration	1,507
Inadequate Forest Buffer	7,942

**Smith Branch Watershed Assessment**

Figure 6.19:  
Subwatershed B  
Existing Conditions



Pinehurst Park

## Channel Conditions:



The upstream extent of the open channel network in SW-B begins north of the Truman and Scurry Street intersection. Channel bed substrate is primarily sand and silt. The right bank is near vertical and is much taller than the left bank. Both banks are vegetated yet show evidence of the channel downcutting and widening. The right bank has been heavily armored with riprap at the Burton-Pack Elementary School stormwater pond outfall and erosion on the left bank has begun to encroach upon adjacent properties. Near the northern end of Hammond Avenue, the stream channel becomes more highly incised, with bank stability decreasing and sedimentation increasing; erosion threatens adjacent residential properties, slope failures have exposed bedrock, and land clearing on the right bank has likely contributed to observed slumping.

Downstream, several small tributaries contribute flow to the receiving channel before the stream is conveyed through a culvert under the railroad. A large scour pool has formed at the downstream end of the culvert. Channel substrate in this segment of stream is primarily sand and gravel. Widening has scoured portions of the left bank and concrete slabs and masonry rubble likely contribute to turbulence and instability. The right bank is stable with established vegetation on the bank face.

The stream then becomes channelized with concrete bed and banks, flowing parallel to Ripplemeyer Avenue. Channel conditions along this segment show signs of severe degradation of the concrete channel; soil slump has caused the right bank to fracture and sag. Downstream of the concrete channel, the stream returns to a natural state with earthen bed and banks. Debris caught in understory brush and saturated soils provides evidence of possible flooding. Stream banks are sparsely vegetated with herbaceous material and contain areas of instability. The stream then flows through an 8-foot wide, 6-foot high twin box culvert crossing westerly under Lester Drive. Large sand bars define the channel upon the streams emergence. The stream flows approximately 100 feet before being conveyed through a culvert beneath SC-277 and beyond the SW-B boundary.



## *Ecology*

Stream habitat quality within SW-B is generally poor. High levels of sedimentation, channel alteration, little to no vegetation, and poor epifaunal substrate/available cover were common limitations. The majority (approximately 65%) of the channel in SW-B has a riparian buffer narrower than 35 feet. The upstream segment extends between residential properties and a utility right of way, with patches of forest cover near the large railroad culvert. The downstream segment is a concrete channel within a housing development with no woody vegetation present.



**Constraints:**

- Property Ownership:
  - Overall SW-B Open Channel:
    - Public: 25%
    - Private: 75%
  - Within a 50 Foot Wide Channel Buffer:
    - Public: 27%
    - Private: 73%
- Mapped Drainage Network:
  - Drain Pipe: 55%
  - Open Channel: 45%
- Five longitudinal channel interruptions
- Channel encroachment: utility lines, private property, railroad

**SWM Assessment:**

*Facilities*

There is one mapped stormwater facility within SW-B located to the south of Burton-Pack Elementary School.

*Outfalls*

There were a total of 13 outfalls identified during the field assessment, none of which were assessed to be in severe or very severe condition.

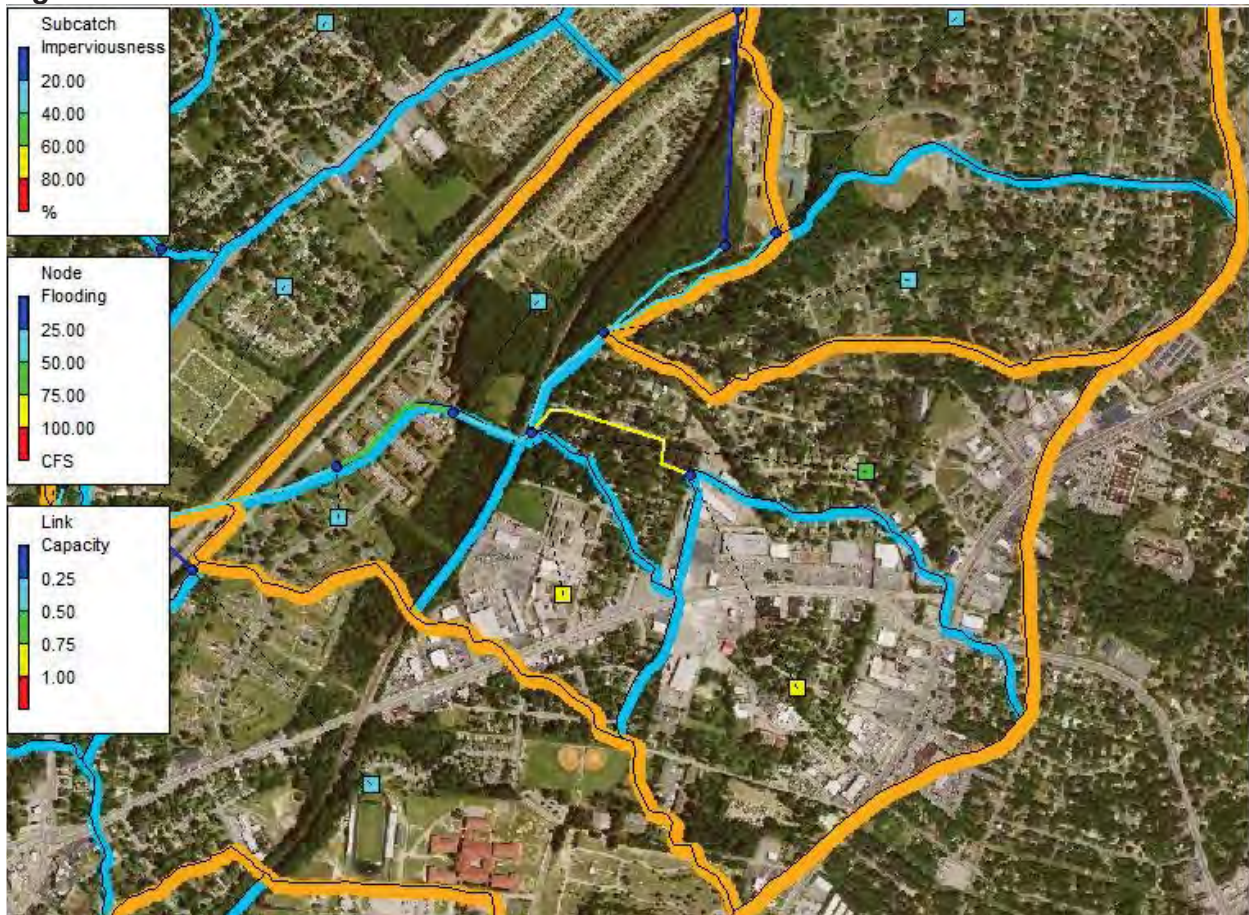
*SWMM*

The SWMM modeling showed that SW-B has a simulated 1.3 peak cfs/acre for a typical 2-year storm event in existing conditions. The 369-acre subwatershed is modeled to create approximately 16.5 million gallons of runoff and 5,986 cubic feet/acre during a 2-year event. The subwatershed is approximately 47% impervious, making it the fourth most impervious subwatershed. Lower slopes in this subwatershed likely contribute to less discharge being modeled during storm events.

SW-B is modeled in SWMM as five subcatchments draining to the pipe and open channel conveyance systems that make up the headwaters of Bay Branch. The large areas of impervious surface in this watershed are visible in the aerial imagery. At the modeled 2-year event in SWMM, the subwatershed's runoff is approaching capacity (81% modeled capacity) in the 54" RCP outlet pipe (seen mapped as yellow lines in **Figure 6.20**).

**Total Subwatershed Runoff Ranking: 4**

**Figure 6.20 SW-B SWMM Model**



**Restoration Opportunities**

The following projects or similar improvements may be considered to address conditions identified in SW-B. These projects are included in **Figure 6.21**.

**Recommended Improvements:**

- As this catchment continues to develop, the development should occur in accordance with the City of Columbia BMP Manual, particularly Sections 1.2.1 and 1.2.3.
- Improvements focused on storage and infiltration are recommended for the large impervious areas. Their location in the watershed, at the far end draining to Bay Branch, makes them high priority candidates to reduce downstream flows and disconnect peaks.
  - Plant trees where feasible in the park south of the Barberry Mews Apartments.
  - Apply the green streets template to reduce runoff from Lester Drive, Bay Shell Drive, Ginger Root Way, Ripplemeyer Way and Colony Forest Drive.
  - Install BMPs for the parking lot behind the Piggie Wiggly on West Beltline Boulevard.
- Repair the exposed utility lines west of Hammond Avenue, South of Lester Drive, and West of Ripplemeyer Avenue.
- Stabilize the banks of the stream segment west of Truman Street.
- Stabilize the headcut west of Hammond Avenue, near the railroad.



**Legend**

- Infrastructure Improvements
- Low Impact Development
- ◆ Reforestation/Buffer Establishment
- ▲ Stormwater Management
- ~ Stream Restoration
- ~ Open Stream Channel
- ⬮ Subwatershed

**Smith Branch  
Watershed Assessment**

Figure 6.21:  
Subwatershed B  
Restoration Opportunities

0 600 1,200  
Feet



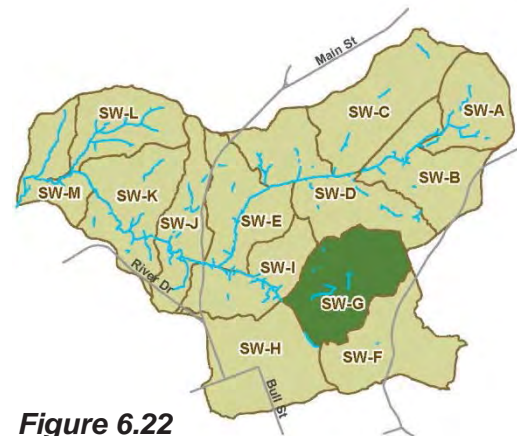
Pinehurst Park

## 6.5 Subwatershed G (SW-G)

### Introduction

#### Setting:

- Subwatershed G (SW-G) is located in the southeastern portion of the watershed.
- SW-G boundaries include Farrow Road to the west, W.A. Perry Middle School to the north, Waites Road to the east, and Elmwood Avenue to the south
- 404 acres or 0.63 square miles in drainage area
- Contains 0.54 miles of open stream channel, and 6.72 miles of mapped storm drain/pipe
- Dominant land use designations (**Figure 6.1, Table 6.1**):
  - Developed, Low Density: 46%
  - Developed, Medium Density: 28%
- Impervious surface cover: 40%



**Figure 6.22**  
**Subwatershed G**

**Soils:** Approximate soil type percentages within SW-G include (refer to **Section 3.4** for soil descriptions and **Figure 6.23** for soil distributions):

- Pelion-Urban land complex, 2 to 10% slopes (PnC): 77%
- Rains sandy loam (Ra): 12%
- Urban land (Ur): 9%
- Johnston loam (Jo): 1%
- Vaocluse loamy sand, 6 to 10% slopes (VaC): 1%




#### Overview:

Although SW-G contains facilities with large developed and impervious footprints, the subwatershed also contains a large amount of open space and a few forested areas. SW-G encompasses Drew Park, C.A. Johnson High School, the CM Tucker Jr Nursing Care Center, and Watkins-Nance Elementary School. Additionally, SW-G contains single-family detached homes throughout the subwatershed and a commercial corridor along Colonial Drive.

### Existing Conditions

**Figure 6.24** highlights existing conditions that were either captured during the stream cruising effort or developed using GIS data.

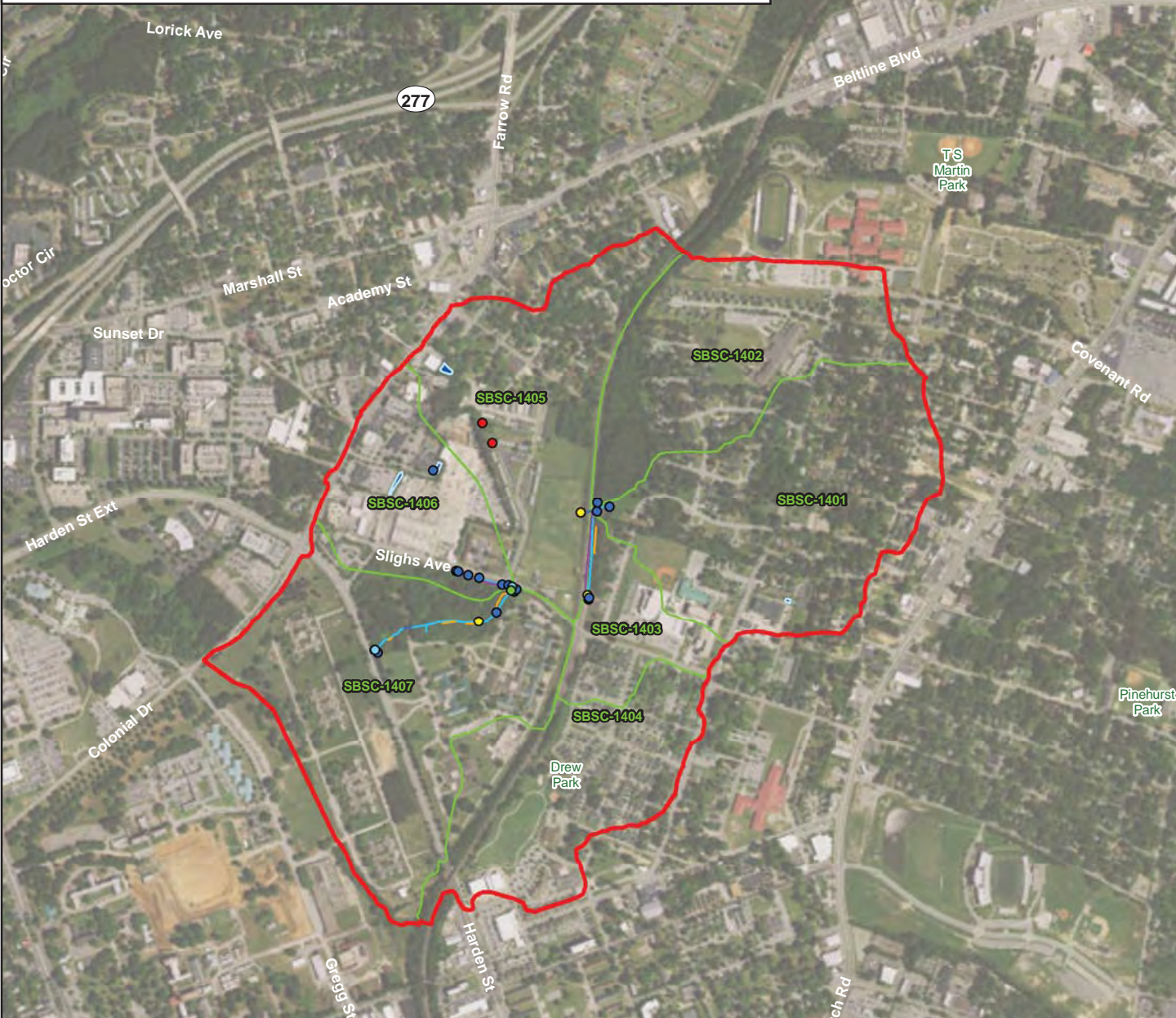
**Legend**

-  Open Stream Channel
-  Soils
-  Subwatershed



**Legend**

- Trash Dumping
- Unusual Condition
- Inadequate Forest Buffer
- Pipe Outfall
- ~ Open Stream Channel
- SWM Facility
- Possible Fish Barrier
- Erosion Site
- SWMM Subcatchment
- Exposed Pipe
- Channel Alteration
- Subwatershed
- Unmanaged Runoff



Existing Condition	Count
Exposed Pipes	2
Pipe Outfalls	16
Unmanaged Runoff	2
Unusual Condition	4
Trash Dumping	0
Possible Fish Barrier	1
	<b>Linear Feet</b>
Erosion Site	1,006
Channel Alteration	121
Inadequate Forest Buffer	1,092

**Smith Branch  
Watershed Assessment**

Figure 6.24:  
Subwatershed G  
Existing Conditions



### Channel Conditions:



The easternmost open channel segment in SW-G is located between the railroad and C.A. Johnson High School. Flow initiates from two 36 inch RCPs that were submerged and backwatered at baseflow. Downstream, the channel is incised, pinched between the railroad embankment and residential properties along Dart Street. Woody bank vegetation adds stability through most of this segment and the channel bed material is primarily sand and silt. The main channel converges with two small tributaries before flowing east through a railroad culvert. The stream

emerges as open channel for 15 feet west of the railroad culvert before it is piped southwest under a driving range. The piped segment outfalls south of Sighs Avenue and east of Howell Avenue.

A 450 foot long tributary extends parallel to Slighs Avenue south of the City of Columbia Fleets Services building. The upstream extent of the tributary begins at two 36 inch RCPs. Channel incision and slumping along the left bank within this segment encroaches upon the roadway and endangers outfalls. The tributary converges with the main channel, described above and below, east of Howell Avenue.

After the tributary flows into the receiving main channel, the channel becomes deeply incised downstream. The 10-foot tall banks are nearly vertical and composed mostly of silt with some bedrock at the toe. As the stream meanders west, bedrock intrusion becomes more frequent in the left bank and there are isolated areas of slumping, while the right bank is more densely vegetated and stable. Depositional mid-channel and point bars frequently constrict and divide baseflow. The stream extends through twin culverts at Eagle Avenue. Downstream



of the road crossing, there are isolated areas of erosion. The stream is then piped west under Harden Street and beyond the SW-G boundary onto the Bull Street Redevelopment property.

### *Ecology*

The open channel segments within SW-G have poor overall stream habitat quality. The channel segment north of Slighs Avenue, parallel to the railroad, has poor epifaunal substrate/available cover, high sedimentation, one velocity/depth regime, and a narrow riparian buffer. The channel segment south of Slighs Avenue is impacted by poor bank stability, marginal vegetative cover on the bank faces, and sedimentation in the bed.

Only 20% of the streambanks have less than a 35 foot riparian buffer width. The western side of the stream segment north of Slighs Avenue is encompassed by the railroad embankment, limiting the riparian buffer width. The stream segment parallel to Slighs Avenue has a similarly limited riparian buffer, influenced by the roadway.



---

### Constraints:

- Property Ownership:
  - Overall SW-G Open Channel:
    - Public: 60%
    - Private: 40%
  - Within a 50 Foot Wide Open Channel Buffer:
    - Public: 64%
    - Private: 36%
- Mapped Drainage Network:
  - Drain Pipe: 93%
  - Open Stream Channel: 7%
- Four longitudinal channel interruptions
- Channel encroachment: railroad, roads, and private property

### SWM Assessment:

#### *Facilities*

There are four stormwater facilities mapped in this subwatershed. The first, along Waverly Street, is approximately 100 feet south of the intersection with Gordon Street. The three remaining facilities are located behind (east of) commercial properties along Colonial Drive/Farrow Road.

#### *Outfalls*

During the field review, a total of 16 storm drain outfalls were identified within SW-G, all of which were in minor to moderate condition with the exception of two rated severe. The first severely rated outfall is a 48 inch CMP, 30 feet from the mainstem tributary, located west of Dove Terrace. The structure has a six foot vertical drop to the stream channel. Extreme downcutting has undermined the endwall which has begun to slump and crack above the pipe as the stream bank support erodes away. The second outfall rated in severe condition is downstream, adjacent to Harden Street. The discharge contained a chemical smell with a blue/green color and downcutting has undermined and destabilized the concrete pad.

#### *SWMM*

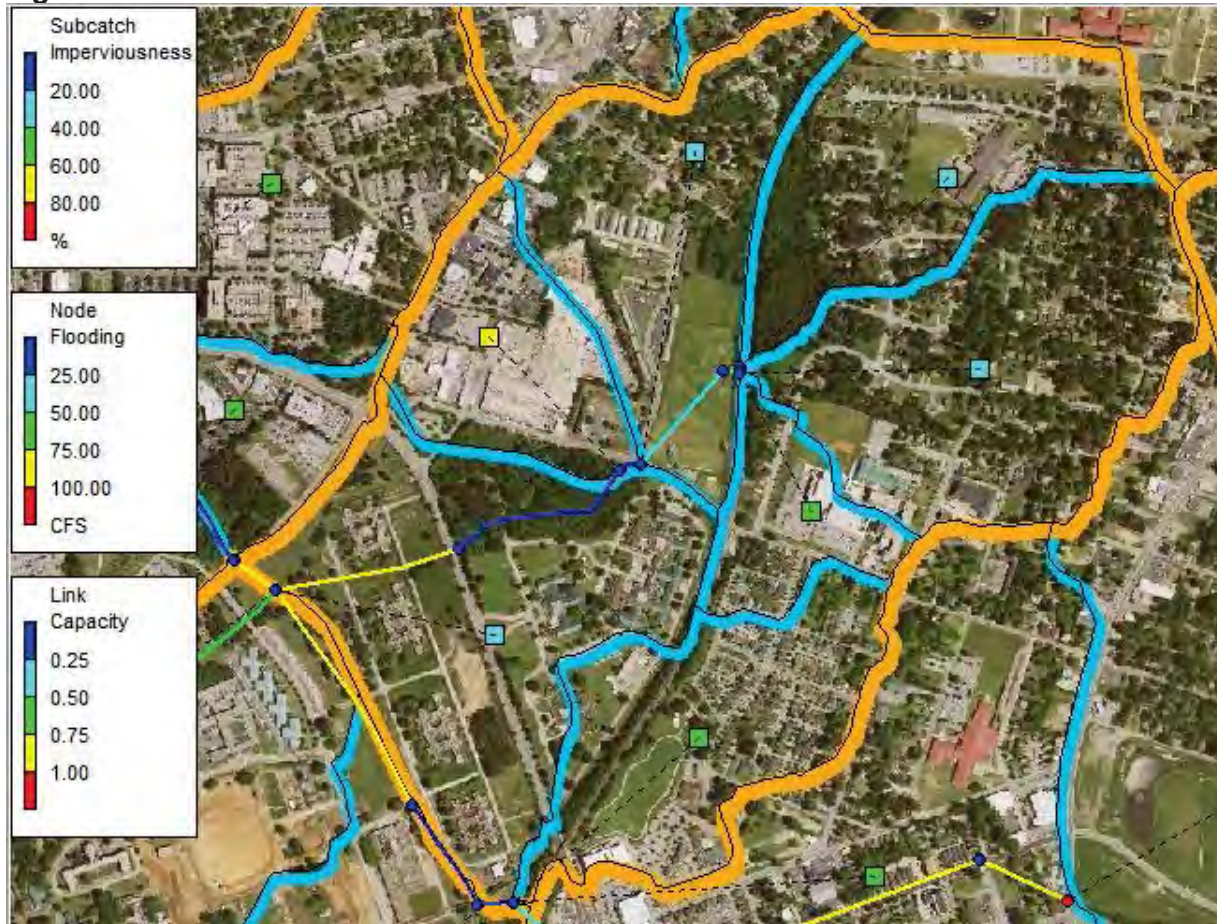
SW-G is adjacent and to the north of SW-F, but has almost 15% less impervious surface than its southern counterpart at 40%, the fifth lowest value for the watershed. With its size of 404 acres, SW-G is modeled with SWMM to produce 16.0 million gallons of runoff and 5,303 cubic feet/acre for a 2-year storm, both ranking at fifth highest in the watershed. However, the discharge per acre for the 2-year event is the highest at 1.5 peak cfs/acre, which reflects the influence of higher slopes in the subwatershed despite the relatively low amount of impervious surface.

SW-G is modeled as seven subcatchments (**Figure 6.25**). Six of these subcatchments drain to the 84 inch RCP at the western end of the subwatershed. The remaining subcatchment is modeled as draining to the upper end of the large dual culverts at Preston Drive. One subcatchment in this subwatershed is mostly commercial and approximately 70% impervious. The dual 84 inch RCPs that begin at Preston Drive are estimated to be at almost 80% capacity

due to the flows from SW-F and SW-G during a 2-year storm event. The undeveloped green space in this area should be further investigated for ways to store and infiltrate water.

### Total Subwatershed Runoff Ranking: 5

**Figure 6.25 SW-G SWMM Model**



### Restoration Opportunities

The following projects or similar improvements may be considered to address conditions identified in SW-G. These projects are included in **Figure 6.26**.

#### **Recommended Improvements:**

- Opportunities for infiltration and storage should be investigated here to slow the timing of peaks and limit coincident peaks downstream, particularly in the large commercial area and the green space around the dual pipes below Preston Drive.
  - Install green roof units on the City of Columbia Fleet Services Building and install BMPs in the parking lots.
  - Create detention BMP features within the oval walkway grassed area in Drew Park and plant trees where feasible.
  - Plant trees where feasible within the CM Tucker Nursing Care Center, C.A. Johnson High School, the Department of Mental Health Hall Institute building, and Watkins-Nance Elementary School grounds.



- Construct a shallow marsh or wet pool to treat runoff from Howell Street and from the Department of Mental Health Hall Institute building.
- Install bioretention areas in the parking lots of the Palmetto Terrace Apartments and Howell Court.
- Install bioretention areas within the open area around Watkins-Nance Elementary School.
- Install BMPs for the parking lot and tennis courts at the C.A. Johnson High School.
- Restore the stream between Slighs Avenue and Eagle Avenue.
- Daylight the piped stream section between the railroad and Slighs Avenue and the piped section west of Harden Street, within the Bull Street Redevelopment Project.
- As this catchment continues to develop, the development should occur in accordance with the City of Columbia BMP Manual, particularly Sections 1.2.1 and 1.2.3.



**Legend**

- Infrastructure Improvements
- Low Impact Development
- ◆ Reforestation/Buffer Establishment
- ▲ Stormwater Management
- ~ Stream Restoration
- ~ Open Stream Channel
- ⬭ Subwatershed

**Smith Branch  
Watershed Assessment**

Figure 6.26:  
Subwatershed G  
Restoration Opportunities

N  
▲

0 600 1,200  
Feet



## 6.6 Subwatershed D (SW-D)

### Introduction

#### Setting:

- The northernmost point in SW-D is within the Columbia College campus. The boundary extends southeast across SC-277 to Crescent Hill Cemetery off Two Notch Road. The southern boundary extends west through W.A. Perry Middle School to Farrow Road and then northwest to the Lutheran Theological Southern Seminary off North Main Street.
- 506 acres or 0.79 square miles in drainage area
- Contains 2.02 miles of open stream channel and 3.12 miles of mapped storm drain/pipe
- Dominant land use designations (**Figure 6.1, Table 6.1**):
  - Developed, Low Intensity: 52%
  - Developed, Open Space: 20%
- Impervious surface cover: 37%



**Figure 6.27**  
**Subwatershed D**

**Soils:** Approximate soil type percentages within SW-D include (refer to **Section 3.4** for soil descriptions and **Figure 6.28** for soil distributions):

- Pelion-Urban land complex, 2 to 10% slopes (PnC): 64%
- Dothan-Urban land complex, 0 to 6% slopes (DuB): 20%
- Fuquay-Urban land complex, 0 to 6% slopes (FyB): 5%
- Rains sandy loam (Ra): 3%
- Gergeville silt loam, 6 to 10% slopes (GeC): 2%
- Orangeburg-Urban land complex, 2 to 6% slopes (OgB): 2%
- Urban land (Ur): 2%
- Lakeland-Urban land complex, 2 to 6% slopes (LkB): 1%
- Nason complex, 10 to 30% slopes (NaE): 1%
- Johnston loam (Jo): <1%




#### Overview:

SW-D is one of the widest subwatersheds, expanding the full width of the Smith Branch watershed limits at this location. SW-D incorporates a portion of the Columbia College campus, various community buildings, W.A. Perry Middle School, Crescent Hill Cemetery, TS Martin Park and Lorick Park. The SC-277 and Farrow Road interchange is centrally located within the subwatershed. The northern portion of the subwatershed is primarily single-family residences, while to the south the watershed is more mixed use with commercial, institutional, and multi-family residences present.

### Existing Conditions

**Figure 6.29** highlights existing conditions that were either captured during the stream cruising effort or developed using GIS data.

**Legend**

-  Open Stream Channel
-  Soils
-  Subwatershed



**Smith Branch  
Watershed Assessment**

Figure 6.28:  
Subwatershed D  
Soils

0 600 1,200 Feet



**Legend**

- Trash Dumping
- Unusual Condition
- Inadequate Forest Buffer
- Pipe Outfall
- ~ Open Stream Channel
- SWM Facility
- Possible Fish Barrier
- Erosion Site
- SWMM Subcatchment
- Exposed Pipe
- Channel Alteration
- Subwatershed
- Unmanaged Runoff



Existing Condition	Count
Exposed Pipes	24
Pipe Outfalls	43
Unmanaged Runoff	11
Unusual Condition	19
Trash Dumping	0
Possible Fish Barrier	7
	<b>Linear Feet</b>
Erosion Site	1,268
Channel Alteration	5,121
Inadequate Forest Buffer	13,613

**Smith Branch  
Watershed Assessment**

Figure 6.29:  
Subwatershed D  
Existing Conditions

0 600 1,200 Feet

### Channel Conditions:



Within SW-D, the upstream extent of Bay Branch mainstem begins west of the culvert underneath SC-277. The stream flows west through a degraded trapezoidal cellular concrete channel. Large sand bars/benches are prevalent within the reach between SC-277 and Shaw Street. At Shaw Street, the condition of the channel changes, the concrete channel downstream of Shaw Street is smooth concrete, less degraded than the upstream reach, and with little to no deposition or vegetation present within the concrete margins. The channel becomes less degraded, with a

wide bed and angled 6-foot banks. This condition continues throughout the Bay Branch mainstem channel, extending downstream to the SW-D boundary at Lorick Avenue. Four significant tributaries are included within SW-D and contribute flow to Bay Branch.

The easternmost tributary in SW-D originates from two grass drainage swales within TS Martin Park, in the southeastern region of the subwatershed. The two swales drain into an 18 inch RCP south of the baseball fields. The pipe is not included in City GIS. It is believed to extend to the western side of Edison Street where open channel originates at a 36 inch RCP outfall. Downstream of Edison Street streambanks are low and vegetated, with only isolated areas of scour. The channel network becomes open and braided further downstream, resembling a scrub-shrub wetland. Flow is conveyed under TS Martin Drive through a 48 inch RCP and continues downstream with wetland-like conditions. A piped section is not included in City GIS, but the channel is likely piped under West Beltline Boulevard and emerges east of Bailey Street. The stream here is channelized within an apartment complex. The banks are mowed to top of bank and lack vegetative protection. Highly erodible bank materials are actively sloughing into the stream. The bed material primarily consists of sand, with some gravel and cobble along the riffles. Channel incision and widening has exposed two sanitary lines and threatens the base of multiple utility poles. The channel is then piped north, emerging for a short distance north of Lester Drive before passing under SC-277 and converging with the Bay Branch mainstem, east of Bethune Court.



The second major tributary originates from south of SC-277 and west of Farrow Road. Open stream channel originates from a 36 inch RCP southwest of the intersection of Water Street and Adams Street. The tributary is then piped north under SC-277. Another segment of open channel originates from 52 inch RCP west of Water Street between Chappelle Street and Lorick Avenue. A third of the banks within this segment are actively eroding where the channel is tightly confined between private residential properties. The stream is piped underneath Chappelle Street then emerges from a 48 inch RCP into the Bay Branch mainstem east of Colonial Drive.



Open stream channel within the third major tributary originates at three pipe outfalls east of the Seaboard Avenue and Colonial Drive intersection. Seaboard Avenue was closed at the time of the stream cruising effort. It had appeared as though recent flooding and erosion had undermined the road and underground utilities. The outfall instability is discussed in further detail below. Channel substrate in the downstream tributary reach primarily consists of sand with some silt and gravel. The downstream end of this segment is incised, with 6-foot tall, vegetated banks with isolated

regions of scour. As the stream flows south it is piped under Cromer and Hurst Streets. Downstream of Hurst Street, the stream bed is concrete with vertical 5-foot grouted stone walls. There are large sand deposits in the reach between Hurst and Manse Streets. The channel extends under Manse Street, with similar concrete channel conditions downstream. The tributary joins Bay Branch approximately 120 feet east of Colonial Drive.

The upstream extent of the fourth major tributary initiates in a forested parcel south of Wentworth Drive and east of Kinderway Avenue. Streambanks are mostly stable and well vegetated, with some isolated areas of moderate erosion. Channel substrate consists of silt and sand, with some gravel along the riffles. Downstream, the stream is routed through a large pond before passing underneath railroad tracks to the south and entering Lorick Park. The railroad culvert appears to be blocked on the downstream side by riprap recently placed on the embankment face. Downstream of the railroad, the channel is incised with 7-foot banks, thick established vegetation, and bedrock at the toe and in the bed. A wetland seep flows into this tributary north of the baseball diamond. Stream conditions change downstream of the confluence; the bank heights lower and the understory vegetation thins as the stream enters the maintained section of the park. Bed substrate changes to primarily gravel with substantial quantities of sand and cobble. The stream is then piped along Lorick Avenue, and enters Bay Branch immediately upstream of the Lorick Avenue crossing.



### *Ecology*

SW-D is a large subwatershed with many segments of stream and varying degrees of stream habitat quality. The main channel within this subwatershed, along Bay Branch, is entirely channelized with concrete bed and banks. The lack of substrate diversity, vegetation, and velocity/depth regimes lead to poor habitat quality within this section of channel. The open channel tributary south of Hurst Street is similarly poor with a concrete bed and grouted stone banks. Upstream, the segment of tributary channel north of Cromer Street is more naturalized, with some bank erosion but more vegetation and bed diversity.

The segment of tributary within TS Martin Park has better stream habitat quality, but is impacted by a lack of riffles, sedimentation, and only shallow, slow flow. Further downstream of this



segment, the open channel that crosses Bailey Street has similar issues, though is degraded further by the absence of vegetative protection.

The tributary that flows through Lorick Park had good overall habitat quality, with some habitat diversity, low sedimentation, and established vegetation. Further upstream, southeast of the corner of Kinderway Avenue and Wentworth Drive, the stream habitat quality is fair, though has higher sedimentation and some bank erosion on the eastern branch.

The majority (approximately 60%) of the stream network within SW-D has less than a 35 foot vegetated buffer surrounding the stream. The notable exceptions are the segments within Lorick Park and TS Martin Park.

#### **Constraints:**

- Property Ownership:
  - Overall SW-D Open Channel:
    - Public: 34%
    - Private: 60%
  - Within a 50 Foot Wide Open Channel Buffer:
    - Public: 61%
    - Private: 39%
- Mapped Drainage Network:
  - Drain Pipe: 61%
  - Open Stream Channel: 39%
- 14 longitudinal channel interruptions
- Channel encroachment: utility poles, sanitary lines, railroad and private property

#### **SWM Assessment:**

##### *Facilities*

There is one mapped stormwater facility in SW-D, located north of Lorick Park.

##### *Outfalls*

During the stream cruising effort, a total of 43 storm drain outfalls were identified within SW-D. Most outfalls are in minor or moderate condition; however, there are three identified as being in severe or very severe condition. One outfall rated as severe is located on the east side of the Colonial Drive roadway embankment between Seaboard Avenue and Cromer Street. Channel incision and base level lowering threaten the stability of the outfall and it was rated severe due to the proximity of instability to the travel lanes of Colonial Drive. The outfall rated very severe is a 36 inch RCP located upstream at the corner of Seaboard Avenue and Colonial Drive. During the stream cruising effort it appeared as though recent flooding and erosion had undermined the road and exposed underground utilities in this location. The third outfall, rated in severe condition, is adjacent to the very severe 36 inch outfall and has been given the severe rating due to separation at the joints of the two terminal segments of this pipe. Recent erosion in this area undermined road and utility lines and closed the road due to damage at the time of the stream cruising effort.

##### *SWMM*

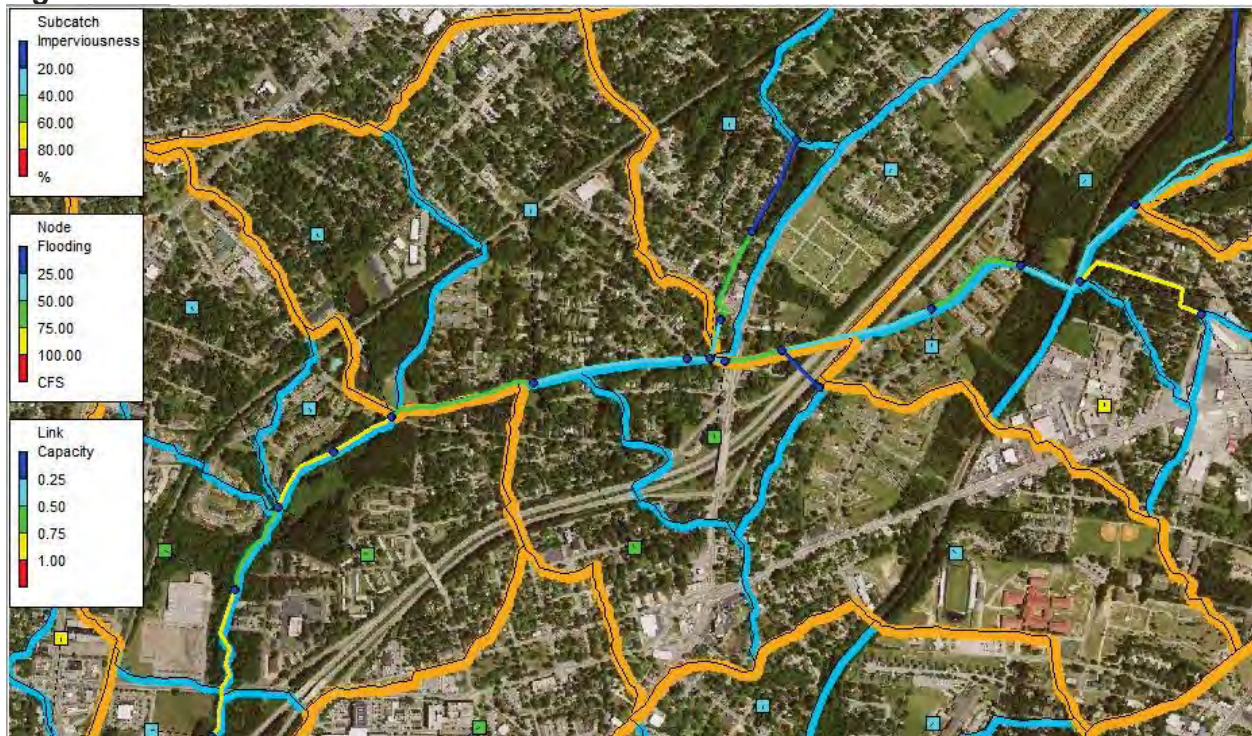
This mixed residential, commercial and institutional subwatershed has an average impervious surface percentage at 37% and is the largest in size at 506 acres. Based on the SWMM modeling,

a 2-year storm event in this subwatershed produces approximately 1.2 peak cfs/acre, which is just over the average of 1.1 peak cfs/acre for the watershed. The total runoff predicted for a 2-year storm event is third largest at 17.7 million gallons and the estimated 4,686 cubic feet/acre of runoff per area is mid-range for the watershed.

SW-D is modeled in SWMM as five subcatchments on either side of Bay Branch. Bay Branch is a concrete-lined trapezoidal channel as it flows through the subwatershed. Due to the low Manning's roughness of concrete, water in this channel will flow at higher velocities. Where the concrete-lined portion of the channel ends, the flow is modeled to enter a backwater condition, causing the link to near its capacity, changing the mapped color to yellow (**Figure 6.30**) at 88% modeled capacity.

### Total Subwatershed Runoff Ranking: 6

**Figure 6.30 SW-D SWMM Model**



### Restoration Opportunities

The following projects or similar improvements may be considered to address conditions identified in SW-D. These projects are included in **Figure 6.31**.

#### Recommended Improvements:

- As this catchment continues to develop, the development should occur in accordance with the City of Columbia BMP Manual, particularly Sections 1.2.1 and 1.2.3.
- Move the utility lines bracketed to the bridges at Grand Street and Colonial Drive.
- Repair the exposed water line and damaged outfalls south of Seaboard Avenue.



- Repair the exposed sanitary line suspended above the bed southeast of Lester Drive.
- Opportunities for infiltration and storage should be investigated here to reduce peaks downstream.
  - Plant trees where feasible within TS Martin Park and the lot southeast of the intersection of Grant Street and Carver Street.
  - Install a bioretention area between the parking lot and baseball diamonds within TS Martin Park.
  - Install bioretention areas and downspout disconnection for the parking lots of Watkins-Nance Elementary School and W.A. Perry Middle School.
- Stabilize banks and outfalls along the straightened and denuded stream segment within the Colony Apartments.
- Stabilize the banks of the channel south of Chappelle Street.
- Restore the trapezoidal concrete channel within the mainstem of Bay Branch to a more natural condition to help reduce peaks by allowing water to slow and infiltrate in more natural flow patterns.

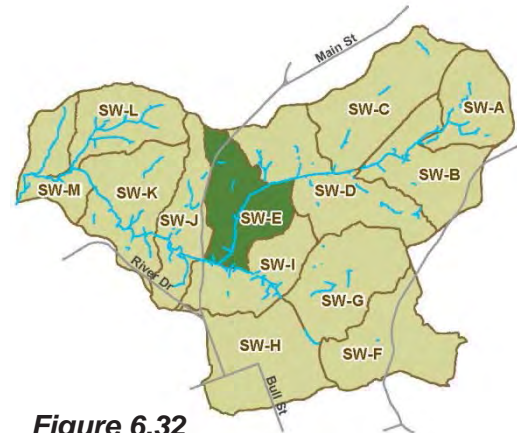


## 6.7 Subwatershed E (SW-E)

### Introduction

#### Setting:

- Subwatershed E (SW-E) is centrally located to the north within the Smith Branch watershed.
- SC-277 is adjacent to the eastern boundary of SW-E, the northeast boundary roughly follows Lorick Avenue, and the western boundary roughly follows North Main Street and Monticello Road. The northernmost point in SW-E is within the Keenan House property.
- 342 acres or 0.53 square miles in drainage area
- Contains approximately 1.37 miles of open stream channel, and 2.80 miles of mapped storm drain/pipe
- Dominant land use designations (**Figure 6.1, Table 6.1**):
  - Developed, Low Intensity: 41%
  - Developed, Medium Intensity: 25%
- Impervious surface cover: 40%



**Figure 6.32**  
**Subwatershed E**

**Soils:** Approximate soil type percentages within SW-E include (refer to **Section 3.4** for soil descriptions and **Figure 6.33** for soil distributions):

- Pelion-Urban land complex, 2 to 10% slopes (PnC): 45%
- Orangeburg-Urban land complex, 2 to 6% slopes (OgB): 20%
- Johnston loam (Jo): 11%
- Gerogeville silt loam, 6 to 10% slopes (GeC): 8%
- Fuquay-Urban land complex, 0 to 6% slopes (FyB): 7%
- Dothan-Urban land complex, 0 to 6% slopes (DuB): 5%
- Orangeburg-Urban land complex, 6 to 15% slopes (OgD): 4%
- Rains sandy loam (Ra): <1%
- Nason complex, 10 to 30% slopes (NaE): <1%




#### Overview:

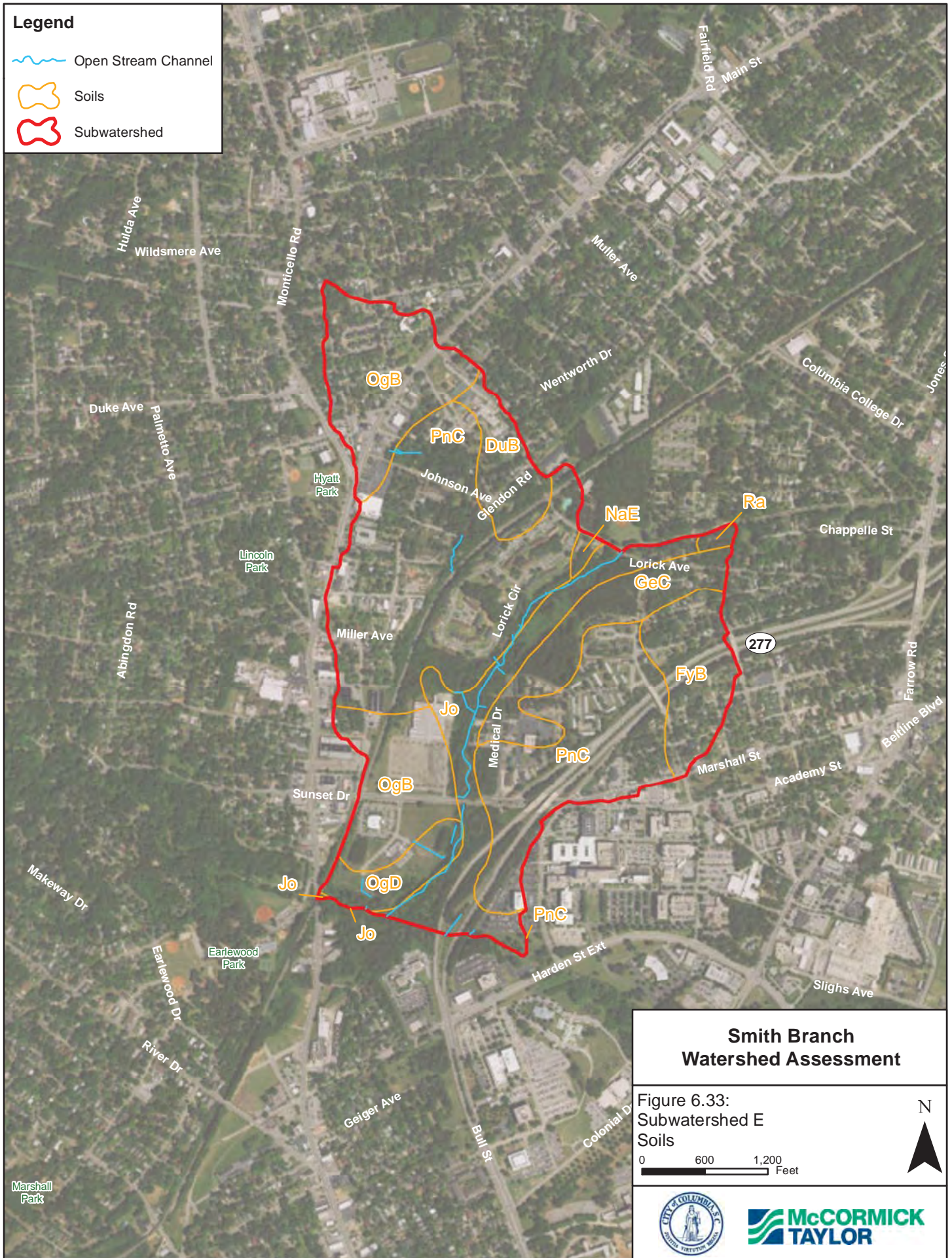
SW-E is centrally located within the Smith Branch watershed and is diverse in land use. To the north are the Lutheran Theological Southern Seminary, the Hyatt Park Elementary School, residential homes, and commercial buildings. A railroad divides the northwestern and southeastern portions of the subwatershed. Southwest of the railroad, SC-277, developed and undeveloped commercial space, and mixed single and multi-family residential lots characterize the land use.

### Existing Conditions

**Figure 6.34** highlights existing conditions that were either captured during the stream cruising effort or developed using GIS data.

**Legend**

-  Open Stream Channel
-  Soils
-  Subwatershed



**Smith Branch  
Watershed Assessment**

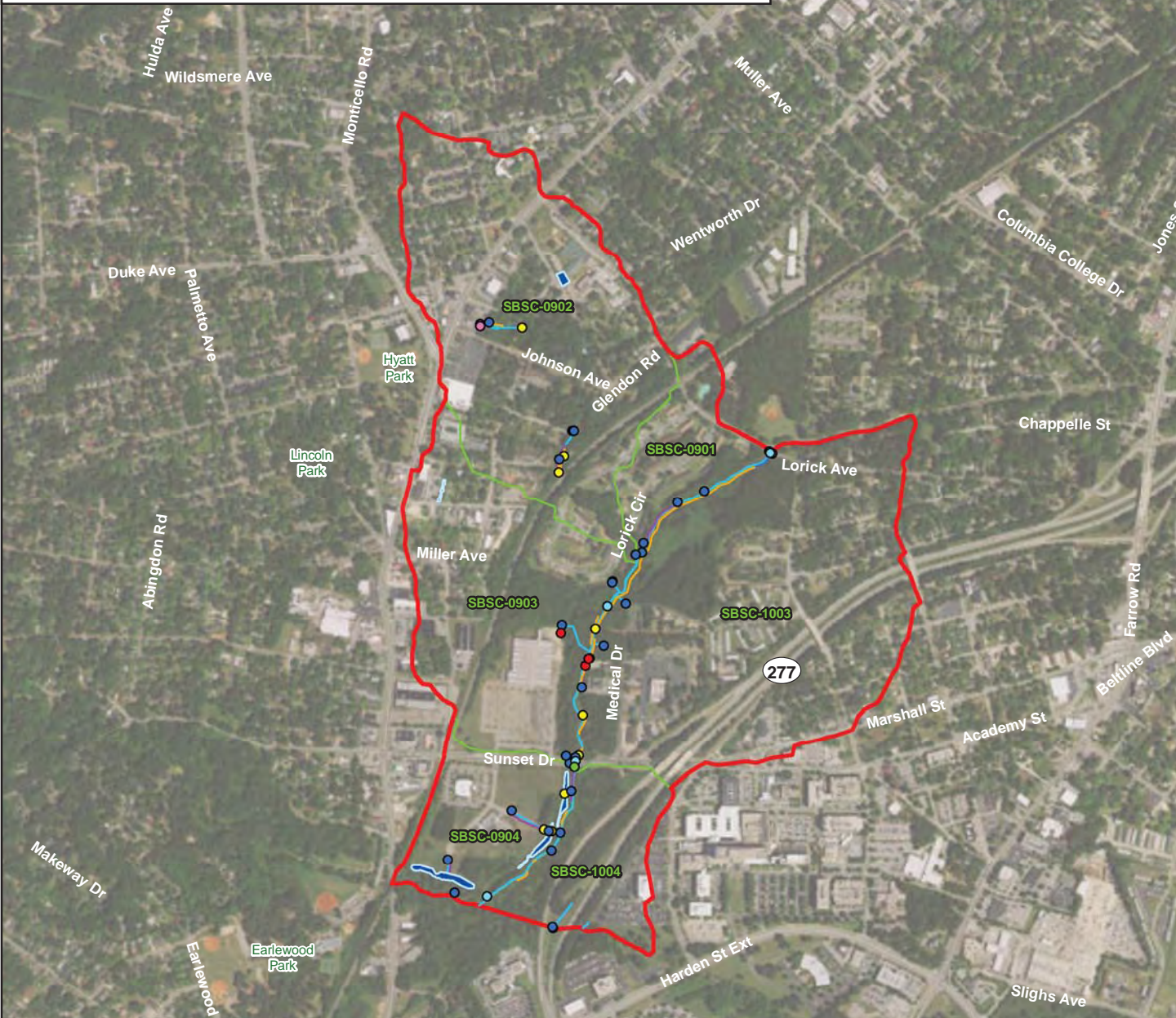
Figure 6.33:  
Subwatershed E  
Soils

0 600 1,200  
Feet



**Legend**

- Trash Dumping
- Unusual Condition
- Inadequate Forest Buffer
- Pipe Outfall
- ~ Open Stream Channel
- SWM Facility
- Possible Fish Barrier
- Erosion Site
- SWMM Subcatchment
- Exposed Pipe
- Channel Alteration
- Subwatershed
- Unmanaged Runoff



Existing Condition	Count
Exposed Pipes	4
Pipe Outfalls	29
Unmanaged Runoff	3
Unusual Condition	11
Trash Dumping	1
Possible Fish Barrier	1
	<b>Linear Feet</b>
Erosion Site	4,901
Channel Alteration	234
Inadequate Forest Buffer	2,433

**Smith Branch  
Watershed Assessment**

Figure 6.34:  
Subwatershed E  
Existing Conditions

N  
▲

0 600 1,200  
Feet



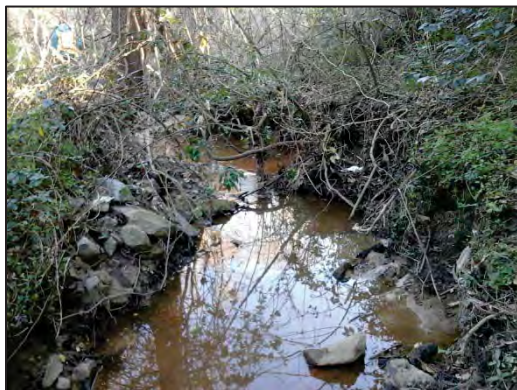
### Channel Conditions:



The upstream extent of the main channel (Bay Branch) in SW-E begins at the Lorick Avenue crossing. The channel bed and banks are initially concrete, changing to natural channel approximately 170 feet downstream of Lorick Avenue. Paralleling Lorick Circle and flowing in a south/southwest direction the channel is entrenched and straight. The cross-sectional area through this reach is significantly smaller than the concrete channel immediately upstream, combined with the increased roughness within the natural channel segment, a backwater condition would be anticipated

as flood flows leave the concrete channel downstream of Lorick Avenue. Channel incision and widening has begun to threaten surrounding infrastructure through this reach. Bedrock is now likely slowing the rate of incision and widening as past erosion has exposed bedrock in the bed and banks. Channel substrate consists of a mix of sand, gravel, and cobble, with bedrock exposed in cascades and riffles.

Along Bay Branch downstream of Lorick Circle, erosion continues to impact the streams surrounding environment and threatens overhead utility poles, sanitary lines, and the parking lot of the Alston Wilkes Veterans Home off Medical Drive. Downstream of the Veterans Home parking lot, sinuosity increases, and there is isolated erosion at the outside of bends with depositional point bars on the inside. The percent sand increases within the bed through this reach, with some gravel and cobble along riffles. The stream extends through a quad box culvert under Sunset Drive. Downstream of the quad culvert is an 18-inch vertical baseflow water surface drop. Downstream of Sunset Drive, the substrate is primarily sand. The banks are fairly stable and well established with woody vegetation. A few areas of isolated minor to moderate erosion exist, undercutting trees and scouring the outside of bends. Bay Branch within SW-E concludes at the downstream subwatershed boundary, where it flows into the mainstem of Smith Branch.



There are two isolated stream segments within the central and northern portions of the subwatershed. They are connected through a storm drain network. The upstream and northernmost segment originates from a 24 inch CPP outfall east of North Main Street, between Jackson and Johnson Avenues. Incision has led to bank instability within the upstream 130 feet of open channel. Bed material consists primarily of cobble with some sand and gravel. The stream drops several feet into an inlet south of the Marsteller Street and Jackson Avenue intersection. Flow is then piped



east and south before emerging into the second open channel segment, east of the Glendon Road and Hendrix Street intersection. Channel widening is causing some scouring at the outside of bends. Bed material shifts to predominantly sand within this segment, with some cobble and gravel within riffles. The segment concludes where flow drops several feet into an open box inlet which conveys flow underneath the railroad. The mapped storm drain network is discontinuous in this area; the pipe likely discharges into the Bay Branch mainstem from the right bank south of Lorick Circle.

### *Ecology*

The stream habitat quality the segment of Bay Branch within SW-E is generally degraded. Bank stability and vegetative protection is poor throughout and sedimentation is high. South of Sunset Drive, the habitat quality improves, primarily through more stable banks and greater bank vegetation, though sedimentation is extensive. The two segments of tributary channel near North Main Street have poor stream habitat quality as well. Bank instability, poor vegetative protection and sedimentation are common impairments for these segments.

The majority of the stream network in SW-E has an adequate riparian buffer, with only approximately 20% having less than a 35 foot width. Isolated areas of channel encroachment are the primary impaired sections.

### **Constraints:**

- Property Ownership:
  - Overall SW-E Open Channel:
    - Public: 53%
    - Private: 47%
  - Within a 50 Foot Wide Open Channel Buffer:
    - Public: 53%
    - Private: 47%
- Mapped Drainage Network:
  - Drain Pipe: 67%
  - Open Stream Channel: 33%
- Four longitudinal channel interruptions
- Channel encroachment: private commercial and residential property, railroad, and utilities

### **SWM Assessment:**

#### *Facilities*

In the northern portion of SW-E, a stormwater facility was identified in City GIS data. Field review determined this is likely an underground facility. Three ponds were mapped east and south of Park Central Drive.

#### *Outfalls*

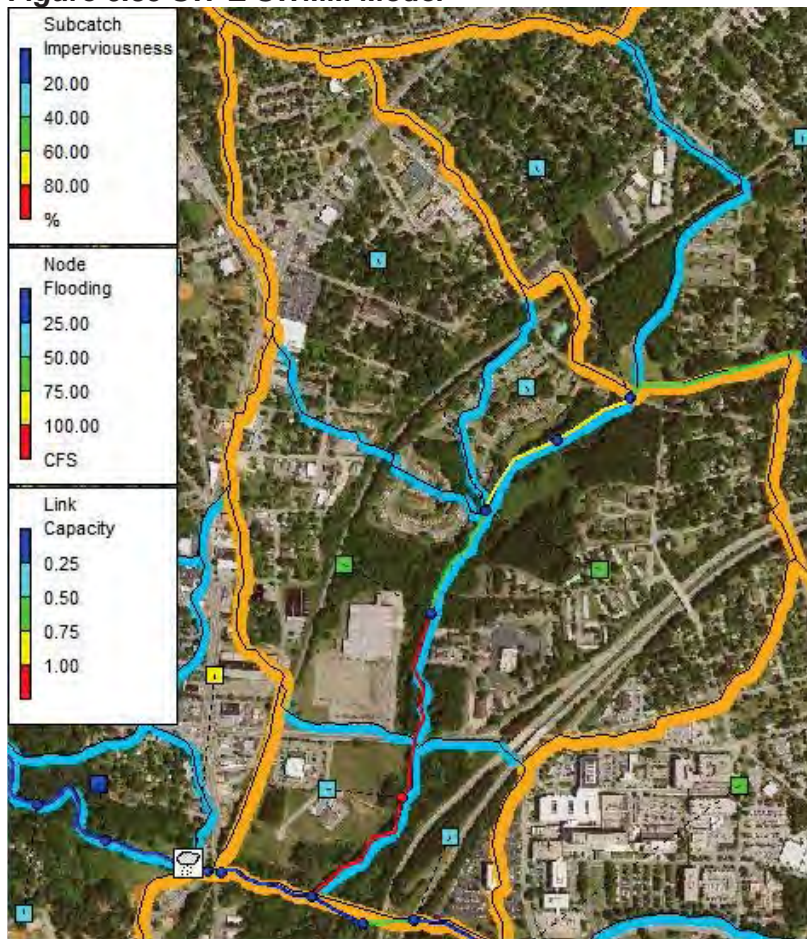
During the field review, a total of 29 stormwater outfalls were identified within SW-E, all of which were noted to be in minor to moderate condition with the exception of two outfalls that were in severe condition. The first severe outfall is west of the Medical Drive, Doctors Circle intersection, 80 feet from Bay Branch. The outfall channel has downcut and the 30 inch CMP outfall has destabilized with a minimum of two terminal segments disjointed. The other severe

outfall is east of North Main Street between Jackson Avenue and Johnson Avenue and has been given a severe rating due incision and bank instability extending downstream from the outfall.

### SWMM

SW-E is another one of the contributing subwatersheds to Bay Branch and consists of mixed development. The SWMM modeling for SW-E predicts that a 2-year storm event would produce a peak of 1.1 cfs/acre, which is average for the watershed. The subwatershed has just above average impervious surface at 40% compared to the rest of the subwatersheds. The subwatershed is average in size at 342 acres, and as a result, the total runoff volume modeled for a 2-year storm event is 13.0 million gallons, also average for the watershed. The runoff per area is 5,073 cubic feet/acre, slightly above average among the subwatersheds.

**Figure 6.35 SW-E SWMM Model**



SW-E is modeled as six subcatchments in SWMM. It makes up the lower portion of Bay Branch. The more impervious commercial areas of this subwatershed can be seen along the western boundary in the aerial imagery (**Figure 6.35**). Where Bay Branch meets Smith Branch, flooding issues are modeled to occur during the 2-year event as this area of the tributary reaches 100% capacity and water begins to flow into the overbank areas. Bay Branch itself has been highly



altered in areas with concrete linings at the top of this catchment that cause more rapid stream flow peaks down the tributary to Smith Branch, resulting in more flooding issues downstream.

**Total Subwatershed Runoff Ranking: 7**








**Restoration Opportunities**

The following projects or similar improvements may be considered to address conditions identified in SW-E. These projects are included in **Figure 6.36**.

**Recommended Improvements:**

- As this catchment continues to develop, the development should occur in accordance with the City of Columbia BMP Manual.
- Opportunities for infiltration and storage should be investigated here to reduce peaks downstream.
  - Remove parking lot sections adjacent to stream and install BMPs at the Alston Wilkes Veterans Home.
  - Install BMPs on the large abandoned parking lot north of SC-16 and west of SC-277.
  - Plant trees where feasible at the Hyatt Park Elementary School, the empty lot off Glendon Road, at the Latimer Manor, and the SC-277 median.
- Restore the segment of Bay Branch east of Lorick Circle, including bank stabilization, floodplain reconnection, and BMPs.
- Move the exposed sanitary line away from the culvert opening at the Sunset Drive crossing.
- Stabilize the outfalls west of Medical Drive and east of North Main Street.
- Development in flood-prone areas near Smith Branch should be restricted. In addition, open space floodplains on the south side of this catchment should be investigated for permanent protection under easements or restrictive covenants.

**Legend**

-  Infrastructure Improvements
-  Low Impact Development
-  Reforestation/Buffer Establishment
-  Stormwater Management
-  Stream Restoration
-  Open Stream Channel
-  Subwatershed



**Smith Branch  
Watershed Assessment**

Figure 6.36:  
Subwatershed E  
Restoration Opportunities

0 600 1,200  
Feet



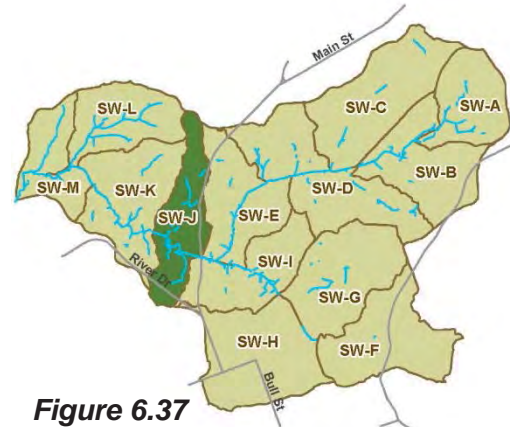


## 6.8 Subwatershed J (SW-J)

### Introduction

#### Setting:

- Subwatershed J (SW-J) contains Hyatt, Lincoln, and Earlewood Parks, as well as the historic Keenan House.
- The northern boundary crosses Monticello Road at Joan Street, the eastern boundary roughly parallels Main Street, the southern boundary is the Union and Clark Streets intersection, and Abingdon Drive is the westernmost boundary.
- 285 acres or 0.45 square miles in drainage area
- Contains 1.68 miles of open stream channel, and 1.94 miles of mapped storm drain/pipe
- Dominant land use designations (**Figure 6.1, Table 6.1**):
  - Developed, Low Intensity: 40 %
  - Developed open space: 25 %
- Impervious surface cover: 33%



**Figure 6.37**  
**Subwatershed J**

**Soils:** Approximate soil type percentages within SW-J include (refer to **Section 3.4** for soil descriptions and **Figure 6.38** for soil distributions):

- Orangeburg-Urban land complex, 2 to 6% slopes (OgB): 54%
- Orangeburg-Urban land complex, 6 to 15% slopes (OgD): 21%
- Pelion-Urban land complex, 2 to 10% slopes (PnC): 18%
- Johnston loam (Jo): 7%




#### Overview:

Within SW-J from north to south; Hyatt Park, Lincoln Park, and Earlewood Park allow for open and recreational space. The remainder of the subwatershed consists of community buildings, forested areas, and single-family residential lots. The commercial corridor along North Main Street runs parallel to the eastern border. This subwatershed contains the greatest number of parks out of any other subwatershed.

### Existing Conditions

**Figure 6.39** highlights existing conditions that were either captured during the stream cruising effort or developed using GIS data.

**Legend**

-  Open Stream Channel
-  Soils
-  Subwatershed



**Smith Branch  
Watershed Assessment**

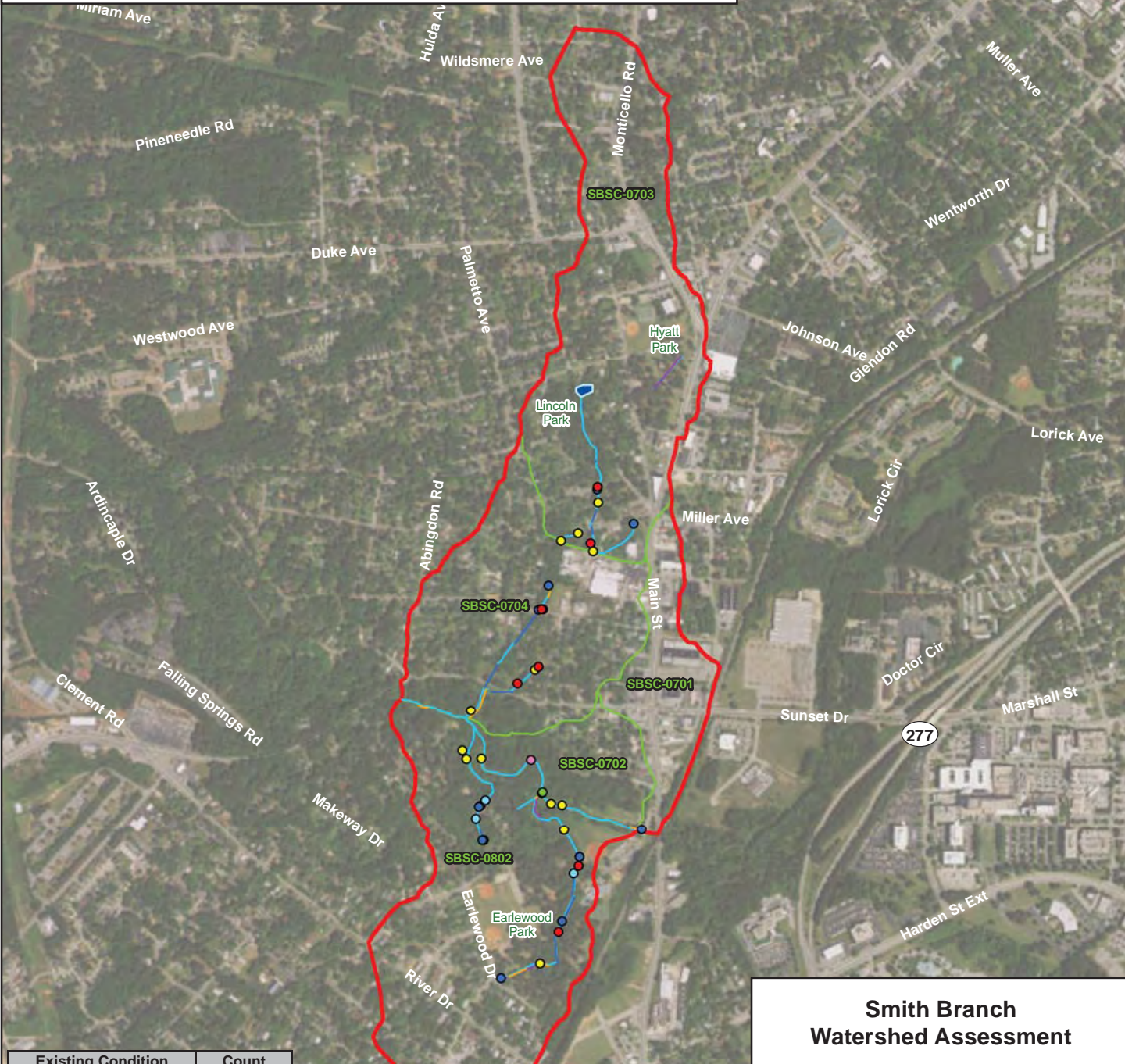
Figure 6.38:  
Subwatershed J  
Soils

0 600 1,200  
Feet



**Legend**

- Trash Dumping
- Unusual Condition
- Inadequate Forest Buffer
- Pipe Outfall
- ~ Open Stream Channel
- SWM Facility
- Possible Fish Barrier
- Erosion Site
- SWMM Subcatchment
- Exposed Pipe
- Channel Alteration
- Subwatershed
- Unmanaged Runoff



Existing Condition	Count
Exposed Pipes	3
Pipe Outfalls	12
Unmanaged Runoff	7
Unusual Condition	15
Trash Dumping	1
Possible Fish Barrier	1
	<b>Linear Feet</b>
Erosion Site	1,380
Channel Alteration	1,934
Inadequate Forest Buffer	2,670

**Smith Branch  
Watershed Assessment**

Figure 6.39:  
Subwatershed J  
Existing Conditions



## Channel Conditions:



Within SW-J the upstream extent of the Smith Branch mainstem begins within Earlewood Park, approximately 120 feet west of Main Street. Banks along this segment are fairly stable, with mature vegetation offering protection. A beaver dam, approximately 800 feet downstream, has created a backwater that extends throughout the upstream limit of this segment. Downstream of the beaver dam, the channel is more sinuous. Banks remain vegetated and stable, and large point bars have formed throughout. Substrate primarily consists of sand, with boulder and

cobble along riffles. The downstream extent of the mainstem segment within SW-J is approximately 80 feet south of the Sunset Drive Summerlea Drive intersection.

Three large tributaries drain to the Smith Branch mainstem within SW-J. The first and easternmost tributary flows into the mainstem 275 feet west (downstream) of Earlewood Park. This stream channel initiates northeast of the Earlewood Drive and Union Street intersection from a 24 inch, concrete outfall. The steep gradient downstream of the outfall has resulted in the migration of a headcut up the slope. The stream extends downstream through multiple small culverts associated with park paths. Substrate in this tributary is primarily riprap, with sand and cobble filling voids between the boulders. Downstream, north of Parkside Drive, the channel is not clearly defined due to a large beaver dam downstream that has created a wetland-like area. Downstream of the beaver dam, the stream lacks a defined single thread channel as it flows through a mudflat and drains into the mainstem at multiple points.



Downstream, the second tributary joins the Smith Branch mainstem from the left bank. The open channel begins upstream from two 18 inch RCP outfalls extending under Keenan Drive, east of the Makeaway Drive and Earlewood Drive intersection. Flow is directed almost immediately under a driveway and continues adjacent single-family residences. The stream is piped under Keenan Drive; upon its exit into the Smith Branch floodplain, the channel becomes less defined as it enters a floodplain wetland complex. The tributary continues downstream roughly parallel to the

Smith Branch mainstem for 550 feet before its confluence with the mainstem.

Approximately 90 feet downstream of the second tributary confluence, the third tributary joins the Smith Branch mainstem from the right bank. Upstream limits of this tributary begins within a wet swale in Hyatt Park. The stream is piped from Hyatt Park to south of Miller Avenue,



where the channel is more entrenched with thick vegetation stabilizing the banks. There is a confluence point southeast of the Miller Avenue and Ridgewood Avenue intersection with another tributary originating from Lincoln Park. The stream segment originating from Lincoln Park is characterized by low, stable banks with heavy vegetation and a sandy bed. Downstream, the channel is piped along a large commercial property southeast of the Miller Avenue and Ridgewood Avenue intersection. Open stream channel emerges from a 60 inch RCP northeast of the

Avondale Drive and Palmetto Avenue intersection. This stream segment is highly entrenched and a commercial property encroaches on the channel from the left bank. The stream is then piped under Avondale Drive and Palmetto Avenue, emerges for 200 feet before being piped under Sunset Drive. Downstream of Sunset Drive, a large scour pool has formed. A small tributary originating from south of Palmetto Avenue converges with the main tributary downstream of the scour pool. Downstream of Sunset Drive, the channel extends approximately 290 feet to its confluence with the Smith Branch mainstem.

### *Ecology*

Stream habitat quality within SW-J was generally good or fair. The mainstem channel is well vegetated, with good bed diversity and epifaunal substrate/available cover. Sedimentation was noted throughout this segment, with large coarse bars and fine sediments accumulating in the pools and within the influence of the beaver dam. The tributary within Earlewood Park is impacted by little vegetative protection, limited velocity/depth regimes and channelization. The tributary that begins in Lincoln Park exhibits limited velocity/depth regimes and high sedimentation.

Overall, a majority (approximately 85%) of the open channel network in SW-J has a greater than 35 foot riparian buffer width. Portions of the channel within Earlewood Park are mowed to the top of bank or riparian vegetation is sparse.

### **Constraints:**

- Property Ownership:
  - Overall SW-J Open Channel:
    - Public: 43%
    - Private: 57%
  - Within a 50 Foot Wide Open Channel Buffer:
    - Public: 75%
    - Private: 25%
- Mapped Drainage Network:
  - Drain Pipe: 54%
  - Open Stream Channel: 46%
- 16 longitudinal channel interruptions
- Channel encroachment: parks and recreation facilities, commercial properties, and private residences



---

## **SWM Assessment:**

### *Facilities*

There is one mapped stormwater facility in the northern portion of SW-J, located within Lincoln Park.

### *Outfalls*

During the field review, a total of 12 storm drain outfalls were identified within SW-J, two of which were rated severe in condition. The first severe outfall, located along Miller Avenue, is a 55 inch RCP with a three foot vertical drop to the mainstem. It has been given a severe rating due to undercutting of erodible materials weakening the base of the structure. The second severe outfall is within Earlewood Park; this structure is a 24 inch CMP with a blue/green colored discharge that is backwatered into the outfall.

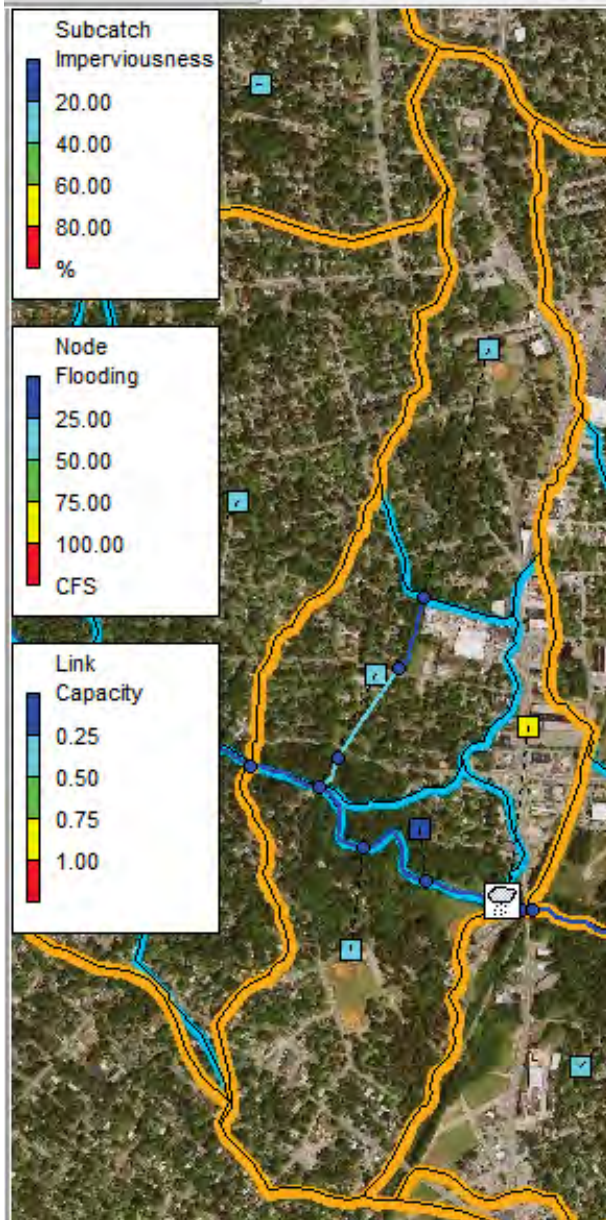
### *SWMM*

SW-J is a moderately developed subwatershed that is average for both size and imperviousness within the Smith Branch subwatershed. It contains commercial and residential development combined with moderate slopes. The 285-acre subwatershed has impervious surface at 33%, and drains to Smith Branch from the north and south in stream channels highly impacted by what appears to be long-existing development. Based on the SWMM modeling for a 2-year storm event, SW-J will produce approximately 1.1 peak cfs/acre, which is average for the watershed. The total runoff volume predicted for this type of storm is 9.2 million gallons and the runoff volume per area is 4,292 cubic feet/acre, both of which are on the lower end of subwatershed values. As a result, SW-J ranked eighth overall.

SW-J is modeled in SWMM as five subcatchments (**Figure 6.40**). One subcatchment, along Main Street, is highly impervious at approximately 78%. The areas further from Smith Branch are more suburban and lower in imperviousness. These less-developed areas and any open space in the floodplain by Smith Branch are candidates for additional protection where flood attenuation and/or storage may be more feasible.

**Total Subwatershed Runoff Ranking: 8**

**Figure 6.40 SW-J SWMM Model**



**Restoration Opportunities**

The following projects or similar improvements may be considered to address conditions identified in SW-J. These projects are included in **Figure 6.41**.








**Recommended Improvements:**

- As this catchment continues to develop, the development should occur in accordance with the City of Columbia BMP Manual.
- Restoration opportunities for impacted urban stream channels should be investigated, particularly at publicly-owned park sites (e.g. Earlewood Park), where flood attenuation and/or storage may be more feasible.



- Stabilize the outfall south of Miller Avenue.
- Repair the outfall east of Earlewood Drive, check for source of blue/green discharge and stabilize the banks downstream of the outfall.
- Plant trees where feasible within Hyatt Park, Earlewood Park, and northeast of the intersection of Sunset Drive and Margrave Road.
- Install bioretention areas and downspout disconnection for parking lots at the Burton-Pack Elementary School and the associated recreational area.
- Development in flood-prone areas near Smith Branch should be restricted. In addition, open space floodplains where Smith Branch flows through this catchment should be investigated for permanent protection under easements or restrictive covenants.

**Legend**

-  Infrastructure Improvements
-  Low Impact Development
-  Reforestation/Buffer Establishment
-  Stormwater Management
-  Stream Restoration
-  Open Stream Channel
-  Subwatershed



**Smith Branch  
Watershed Assessment**

Figure 6.41:  
Subwatershed J  
Restoration Opportunities

0 600 1,200 Feet

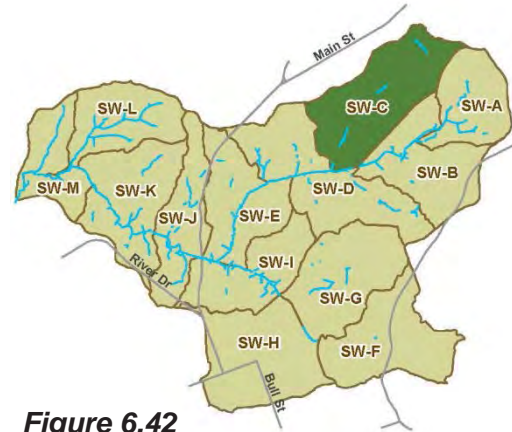


## 6.9 Subwatershed C (SW-C)

### Introduction

#### Setting:

- Subwatershed C (SW-C) is the northernmost subwatershed within the Smith Branch watershed.
- The SW-C boundaries are defined by SC-277 to the southeast, Muir Street to the north, Colonial Drive to the northwest/west, and the southernmost point lies approximately 200 feet west of the Farrow Road, Bethune Court intersection
- 463 acres or 0.72 square miles in drainage area
- Contains 0.52 miles of open stream channel, and 1.62 miles of mapped storm drain/pipe
- Dominant land use designations (**Figure 6.1, Table 6.1**):
  - Developed, Low Intensity: 45%
  - Developed, Medium Intensity: 23%
  - Developed, Open Space: 23%
- Impervious surface cover: 31%



**Figure 6.42**  
**Subwatershed C**

**Soils:** Approximate soil type percentages within SW-C include (refer to **Section 3.4** for soil descriptions and **Figure 6.43** for soil distributions):

- Fuquay-Urban land complex, 0 to 6% slopes (FyB): 33%
- Pelion-Urban land complex, 2 to 10% slopes (PnC): 31%
- Rains sandy loam (Ra): 15%
- Lakeland-Urban land complex, 2 to 6% slopes (LkB): 9%
- Dothan-Urban land complex, 0 to 6% slopes (DuB): 6%
- Urban land (Ur): 5%
- Udorthents (Ud): 1%
- Johnston loam (Jo): <1%




#### Overview:

SW-C is primarily a suburbanized subwatershed. The eastern/southeastern boundary is defined by SC-277. The largest parcels are located within the eastern portion of the subwatershed and include Bayberry Mews residential complex and Lincoln Cemetery, along with churches and commercial buildings with large parking areas. The remainder of the subwatershed is primarily single-family detached homes within established neighborhoods. A railroad bisects the subwatershed, extending roughly parallel to SC-277, northwest of Farrow Road

### Existing Conditions

**Figure 6.44** highlights existing conditions that were either captured during the steam cruising effort or developed using GIS data.

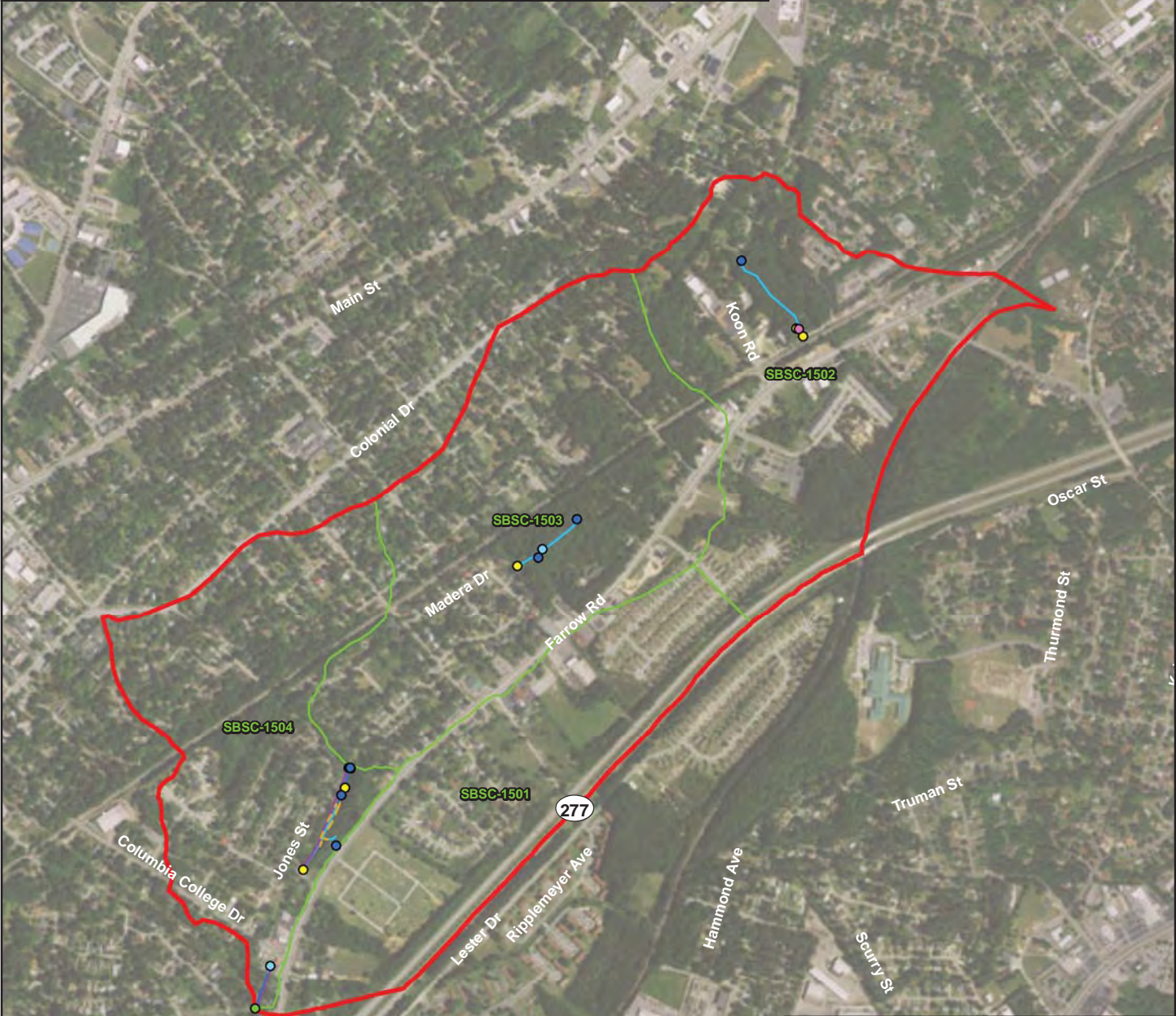
**Legend**

-  Open Stream Channel
-  Soils
-  Subwatershed



**Legend**

- Trash Dumping
- Unusual Condition
- Inadequate Forest Buffer
- Pipe Outfall
- ~ Open Stream Channel
- SWM Facility
- Possible Fish Barrier
- Erosion Site
- SWMM Subcatchment
- Exposed Pipe
- Channel Alteration
- Subwatershed
- Unmanaged Runoff



Existing Condition	Count
Exposed Pipes	2
Pipe Outfalls	9
Unmanaged Runoff	0
Unusual Condition	5
Trash Dumping	1
Possible Fish Barrier	1
	<b>Linear Feet</b>
Erosion Site	403
Channel Alteration	631
Inadequate Forest Buffer	1,554

**Smith Branch  
Watershed Assessment**

Figure 6.44:  
Subwatershed C  
Existing Conditions

0 600 1,200 Feet

N

### Channel Conditions:



There are four open channel segments in SW-C. The upstream segment begins at an outfall on the south side of Koon Road and flows through a densely vegetated area before entering a pipe at Ames Road. Channel substrate is comprised of mostly sand and silt. Stream banks are very low, there are various locations of split flow and points where the channel takes on wetland like characteristics with shallow low velocity flow and subtly defined bank margins dense with vegetation.

Approximately 150 feet southwest of Hall Street between Farrow Road and the railroad tracks, an open stream channel emerges from a 24 inch RCP outfall. This segment is centrally located within the subwatershed. Vegetation is thick with an overgrown understory supporting bank stability. Substrate is primarily sand, with cobble and gravel along the riffles. The open channel segment concludes at the entrance of a 60 inch RCP east of residential properties along Madera Drive.

Downstream, the stream emerges from a 6-foot wide, 3-foot high twin box culvert east of the Vann Street, Jones Street intersection. The stream is channelized with grouted stone walls and a grouted bed with multiple imbricated stone weirs. The rigid channelization continues for approximately 320 feet. Immediately downstream of the grouted segment the banks become sheer and near vertical, and consist of highly erodible materials. Sediment deposition has created small point bars, and riprap and brick in the bed alter flow. A small tributary with a severe headcut contributes flow to the receiving channel approximately 280 feet downstream of the end of concrete channelization. This tributary appears to collect drainage from Farrow Road and an outfall point was collected in the location of suspected drainage along the western side of Farrow Road and is discussed further below. The main open stream channel in this segment enters a 48 inch RCP under Isabel Street.



The downstream most segment of open channel emerges from a 48-inch CMP with a grouted stone headwall south of Columbia College Drive. A 6-inch smooth metal pipe utility crosses the downstream opening of the 48-inch CMP. The left bank is steep and layered with thick vegetation. Approximately 70 feet downstream of the culvert, the stream is channelized with concrete bed and banks. Fine sand deposits are extensive throughout the stream bed within the concrete channel. The stream converges with the receiving main channel (Bay Branch) at the



downstream/southern SW-C boundary.



### *Ecology*

Stream habitat is generally poor in SW-C. The segment of channel at the northern end of the subwatershed has characteristics including infrequent riffles, lack of diversity in velocity/depth regimes, and high sedimentation. The stream segment north of Madera Drive resides in a wooded parcel with established vegetation, low stable banks, and little channel alteration, though sediment deposition is high in pools. The habitat quality in the open channel north of Isabel Street is impaired by sedimentation, lack of riparian vegetation, and poor bank stability. The stream segment south of Columbia College Drive is channelized with a concrete bed and banks, resulting in a poor rating in every category except bank stability.

Overall, approximately 30% of the streambanks have less than a 35 foot riparian vegetated buffer width. The two northernmost sections of stream are located within forested parcels with well-established vegetation. The right riparian buffer of the segment north of Isabel Street is limited by residential properties with mowed lawns. The southernmost segment of stream has sparse tree plantings and mowed grass on both sides.

### **Constraints:**

- Property Ownership:
  - Overall SW-C Open Channel:
    - Public: 22%
    - Private: 78%
  - Within a 50 Foot Wide Open Channel Buffer:
    - Public: 1%
    - Private: 99%
- Mapped Drainage Network:
  - Drain Pipe: 76%
  - Open Stream Channel: 24%
- Two longitudinal channel interruptions
- Channel encroachment: private residential properties

### **SWM Assessment:**

#### *Facilities*

There are no mapped stormwater facilities within SW-C.

#### *Outfalls*

There were nine outfalls identified within SW-C. Only one outfall in SW-C was determined to be in severe condition. This outfall is located west of Lincoln Cemetery, along the western side of Farrow Road. The outfall was not actually clearly identified though drainage patterns and a scoured sump with standing water suggested the presence of an outfall. An outfall point was collected to characterize the severity of the drainage patterns and downstream headcutting observed.

#### *SWMM*

This subwatershed is one of three in the northeastern corner of the watershed that drain to Bay Branch. Based on the SWMM modeling, SW-C is estimated to produce 1.0 peak cfs/acre during a 2-year storm event. This amount is the ninth highest within the watershed. The total quantity of



runoff predicted during a 2-year storm event is 13.6 million gallons, which is in the mid-range relative to the other subwatersheds; the amount of runoff per area is in the lower end of the watershed results at 3,987 cubic feet/acre. SW-C is among the largest at 463 acres and has 31% impervious surface.

SW-C is modeled as four subcatchments in SWMM. Its suburban nature and undeveloped areas can be seen in **Figure 6.45** below. There is a 48 inch RCP, mapped in green below, at the southern end of this subwatershed that is already at approximately 60% modeled capacity during the 2-year event.

**Total Subwatershed Runoff Ranking: 9**

**Figure 6.45 SW-C SWMM Model**



**Restoration Opportunities**

The following projects or similar improvements may be considered to address conditions identified in SW-C. These projects are included in **Figure 6.46**.








**Recommended Improvements:**

- Opportunities for infiltration and storage should be investigated here to reduce peaks downstream due to its location on the edge of the watershed draining to Bay Branch.



- Plant trees where feasible at Busby Street and northeast of Farrow Road and Tarragon Drive.
- Apply green streets template to reduce runoff from Cardamom Court, Tarragon Way, and Ginger Root Way within the Barberry Mews Apartment Complex.
- Move utility line that bracketed to the culvert face south of Columbia College Drive.
- Stabilize the banks and remove the concrete and stone lined channel from the stream segment east of Jones Street.
- As this catchment continues to develop, the development should occur in accordance with the City of Columbia BMP Manual.

**Legend**

-  Infrastructure Improvements
-  Low Impact Development
-  Reforestation/Buffer Establishment
-  Stormwater Management
-  Stream Restoration
-  Open Stream Channel
-  Subwatershed



**Smith Branch  
Watershed Assessment**

Figure 6.46:  
Subwatershed C  
Restoration Opportunities

0 600 1,200 Feet

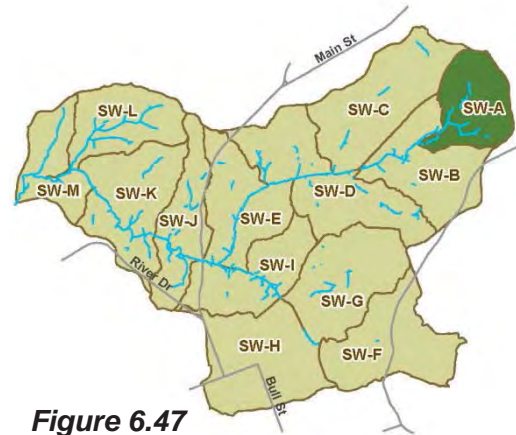


## 6.10 Subwatershed A (SW-A)

### Introduction

#### Setting:

- Subwatershed A (SW-A) is the easternmost subwatershed within the Smith Branch watershed.
- The watershed boundary extends horizontally across Martin Road to the north, vertically across Cushman Drive to the east, its southernmost point is adjacent to the Scurry and Hatfield Street intersection, and Norfolk Southern railroad to the west.
- 273 acres or 0.43 square miles in drainage area
- Contains 1.11 miles of open stream channel, and 0.66 miles of mapped storm drain/pipe
- Dominant land use designations (**Figure 6.1, Table 6.1**):
  - Developed, Low Intensity: 47 %
  - Developed Open Space: 35 %
- Impervious surface cover: 26%



**Figure 6.47**  
**Subwatershed A**

**Soils:** Approximate soil type percentages within SW-A include (refer to **Section 3.4** for soil descriptions and **Figure 6.48** for soil distributions):

- Lakeland-Urban land complex, 2 to 6% slopes (LkB): 35%
- Pelion-Urban land complex, 2 to 10% slopes (PnC): 52%
- Johnston loam (Jo): 10.5%
- Fuquay-Urban land complex, 0 to 6% slopes (FyB): 0.2%
- Rains sandy loam (Ra): 1 %
- Urban land (Ur): 1%
- Lakeland sand, 10 to 15% slopes (LaD): 0.3%




#### Overview:

SW-A is primarily suburban with the majority of the subwatershed developed as single-family, detached homes in established neighborhoods, shaded by a mature tree canopy. A large percentage of the open space in SW-A is associated with the Burton-Pack Elementary School. East of the schools’s entrance, a large open field contains a baseball field, basketball courts, and open recreational space. The primary contributors to the impervious percentage in SW-A are large community buildings, churches, and associated parking lots. A major freeway, SC-277, runs through the northern portion of the subwatershed, also contributing to the impervious surface cover.

### Existing Conditions

**Figure 6.49** highlights existing conditions that were either captured during the stream cruising efforts, or developed using GIS data.

**Legend**

-  Open Stream Channel
-  Soils
-  Subwatershed



**Smith Branch  
Watershed Assessment**

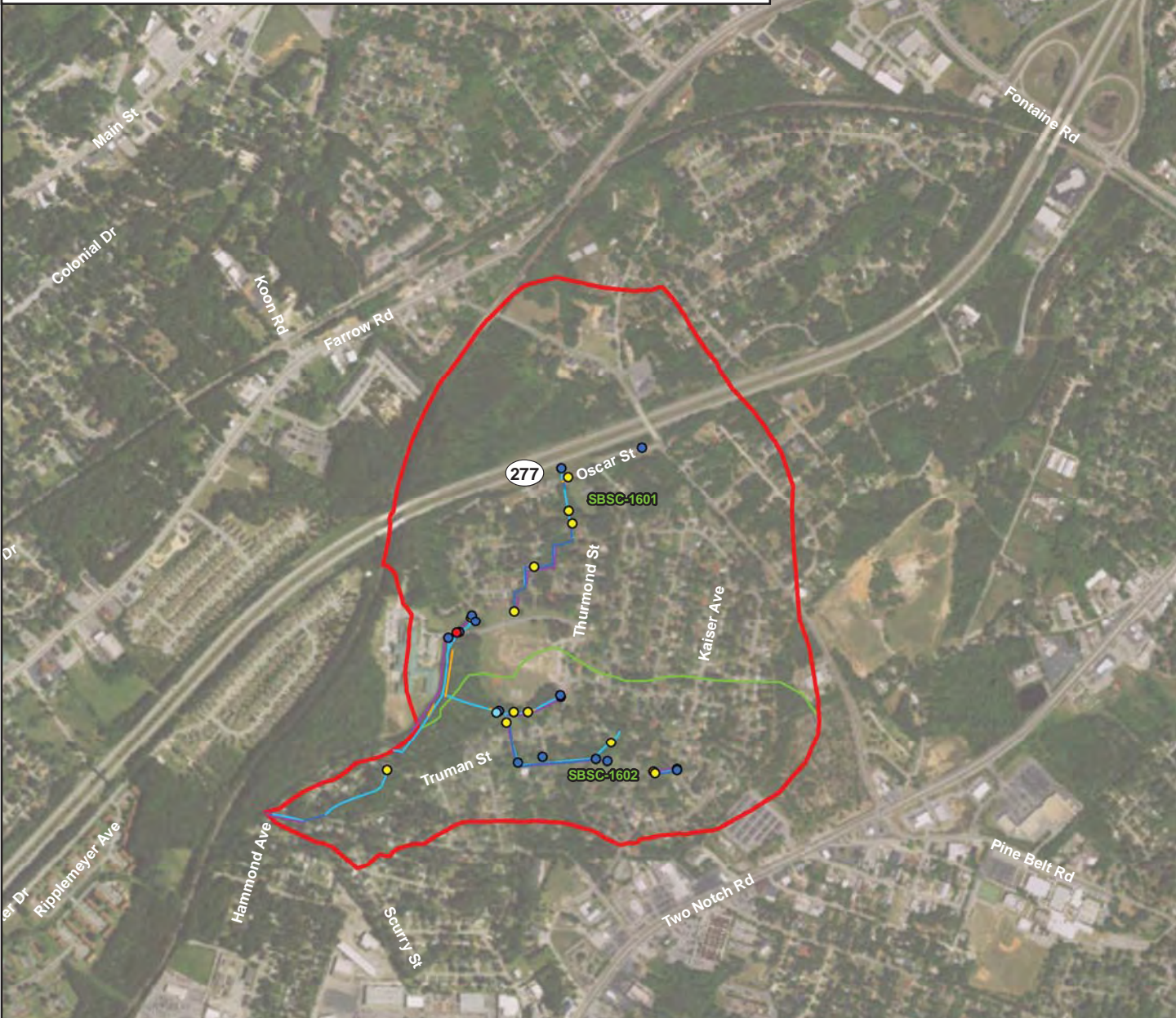
Figure 6.48:  
Subwatershed A  
Soils

0 600 1,200  
Feet



**Legend**

- Trash Dumping
- Unusual Condition
- Inadequate Forest Buffer
- Pipe Outfall
- ~ Open Stream Channel
- SWM Facility
- Possible Fish Barrier
- Erosion Site
- SWMM Subcatchment
- Exposed Pipe
- Channel Alteration
- Subwatershed
- Unmanaged Runoff



**Smith Branch  
Watershed Assessment**

Figure 6.49:  
Subwatershed A  
Existing Conditions



Existing Condition	Count
Exposed Pipes	1
Pipe Outfalls	15
Unmanaged Runoff	1
Unusual Condition	13
Trash Dumping	0
Possible Fish Barrier	0
	<b>Linear Feet</b>
Erosion Site	1,001
Channel Alteration	2,475
Inadequate Forest Buffer	6,125



### Channel Conditions:



The upstream and northern extent of open stream channel within SW-A begins at an outfall emerging from underneath SC-277. The main outfall channel converges with a concrete flume extending along the northern shoulder of Oscar Street. The concrete flume is ephemeral, conveying roadway drainage during storm events. Erosion and flanking along the southern bank of the concrete channel has exposed the base of a fire hydrant. The stream extends downstream through a culvert beneath Oscar Street and opens into a natural stream bed within a forested parcel. Channel substrate

consists primarily of sand, with some gravel and cobble present primarily in riffles. Banks are low, stable and well vegetated. The stream flows approximately 260 feet before it is channelized, with concrete bed and banks. The stream takes multiple abrupt turns, while confined between single-family, detached homes. The concrete channel extends downstream, continuing south of the Webb Court culvert before being piped through a 36-inch RCP north of the entrance road of Burton-Pack Elementary School.

The stream is piped west along the north side of the school entrance for 300 feet before it is again daylighted. Immediately downstream, there is a confluence point with a tributary emerging from a 36 inch RCP. The adjacent landowner expressed concern over frequent flooding in this location. The stream then flows south through a culvert under the school entrance road. The channel is deeply incised downstream of the culvert, with approximately 6 to 7-foot tall banks that are raw in sections but with root structure offering some stability. Bed substrate is primarily sand, with some bedrock intrusion visible at the toe of the banks. A significant tributary converges with the main channel from the left bank approximately 430 feet downstream from the school entrance road culvert. The main channel continues downstream with similar conditions before taking a 90 degree turn west at Truman Street, exiting the subwatershed.



A small drainage ditch flows south of Truman Street between residential lots. Banks are low and vegetated, with bed substrate primarily consisting of sand. The stream passes through a culvert at the corner of Windover Street and Truman Street, is open for approximately 250 feet, then piped under Hammond Avenue into the main channel.

A significant tributary begins from two 18 inch RCP west of Kaiser Avenue. The channel downstream is a dry concrete flume that collects roadway runoff during storm events. The flume continues 175 feet downstream before ending at an inlet. The open channel is piped for 360 feet before exiting



from a 36 inch RCP into a natural bed. The stream becomes channelized with a concrete bed and banks 100 feet downstream of the outfall. The stream turns north sharply and conveys under Truman Street, where the concrete channel ends approximately 90 feet downstream. The stream converges with a small tributary that begins at an outfall at Thurmond Street, south of the elementary school's recreation facilities, and proceeds west. This segment of stream is confined and incised, with approximately 5-foot tall banks and saprolitic clay at the toe and bed; sand was prevalent within pool sections.

### *Ecology*

The stream habitat quality within SW-A ranges from poor to good. The two segments of concrete channel have poor habitat quality, as a result of a lack of vegetation, riffles, and epifaunal substrate/available cover and excessive channel alteration. The tributary south of the Burton-Pack Elementary School recreational fields has good overall habitat quality, with well-established vegetation, stable banks, low sedimentation, and little channel alteration. The main receiving channel south of the elementary school entrance is in fair condition. Habitat is impaired by high levels of sedimentation, infrequent riffles, and a lack of diversity in velocity/depth regimes.

Overall, approximately 55% of the streambanks have less than a 35 foot wide vegetated riparian buffer. The channel segments that are most impacted by the lack of a riparian buffer are the concrete channels. These sections are pinched between single-family detached homes, with little to no space for riparian plantings. The segments adjacent to Burton-Pack Elementary School are in a region of mature forest cover. The stream section between Webb Court and Oscar Street also has a sufficient vegetated riparian buffer.

### **Constraints:**

- Property Ownership:
  - Overall SW-A Open Channel:
    - Public: 32%
    - Private: 68%
  - Within 50 foot wide open channel buffer:
    - Public: 41%
    - Private: 59%
- Mapped Drainage Network:
  - Drain Pipe: 37%
  - Open Stream Channel: 63%
- 10 longitudinal channel interruptions
- Channel encroachment: residential property

### **SWM Assessment:**

#### *Facilities*

There are no mapped stormwater facilities within SW-A.



*Outfalls*

During the field review, a total of 15 storm drain outfalls were identified within SW-A. All observed outfalls were rated minor to moderate in severity.

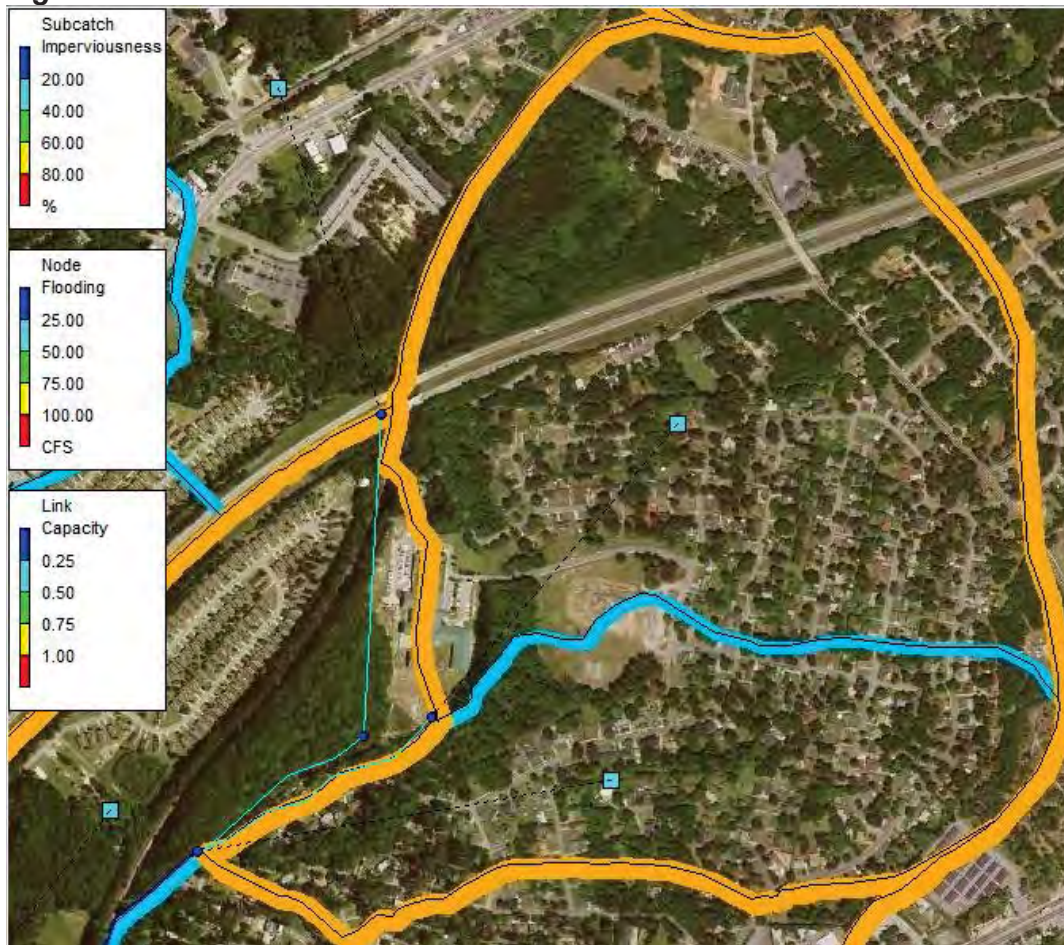
*SWMM*

Based on the SWMM modeling, SW-A is estimated to produce approximately 0.9 peak cfs/acre for a typical 2-year storm event. Of the 13 subwatersheds within the Smith Branch watershed, SW-A ranks as tenth highest, indicating SW-A is on the lower end of peak discharges for the 2-year event. The 272-acre subwatershed is modeled to create approximately 6.8 million gallons of runoff during the 2-year event, approximately the tenth largest contributor in the watershed, based on total volume. Its impervious surface is approximately 26%, relatively low compared to the subwatershed average of 35%.

SW-A is modeled in SWMM as two subcatchments (**Figure 6.50**), each contributing flows directly to open channel conveyance. The open channel conveyance in this part of the watershed has 50% capacity at the 2-year storm event. The suburban nature of this subwatershed can be seen in the aerial imagery, as well as the undeveloped areas in the northern end of it.

**Total Subwatershed Runoff Rating: 10**

**Figure 6.50 SW-A SWMM Model**












### **Restoration Opportunities**

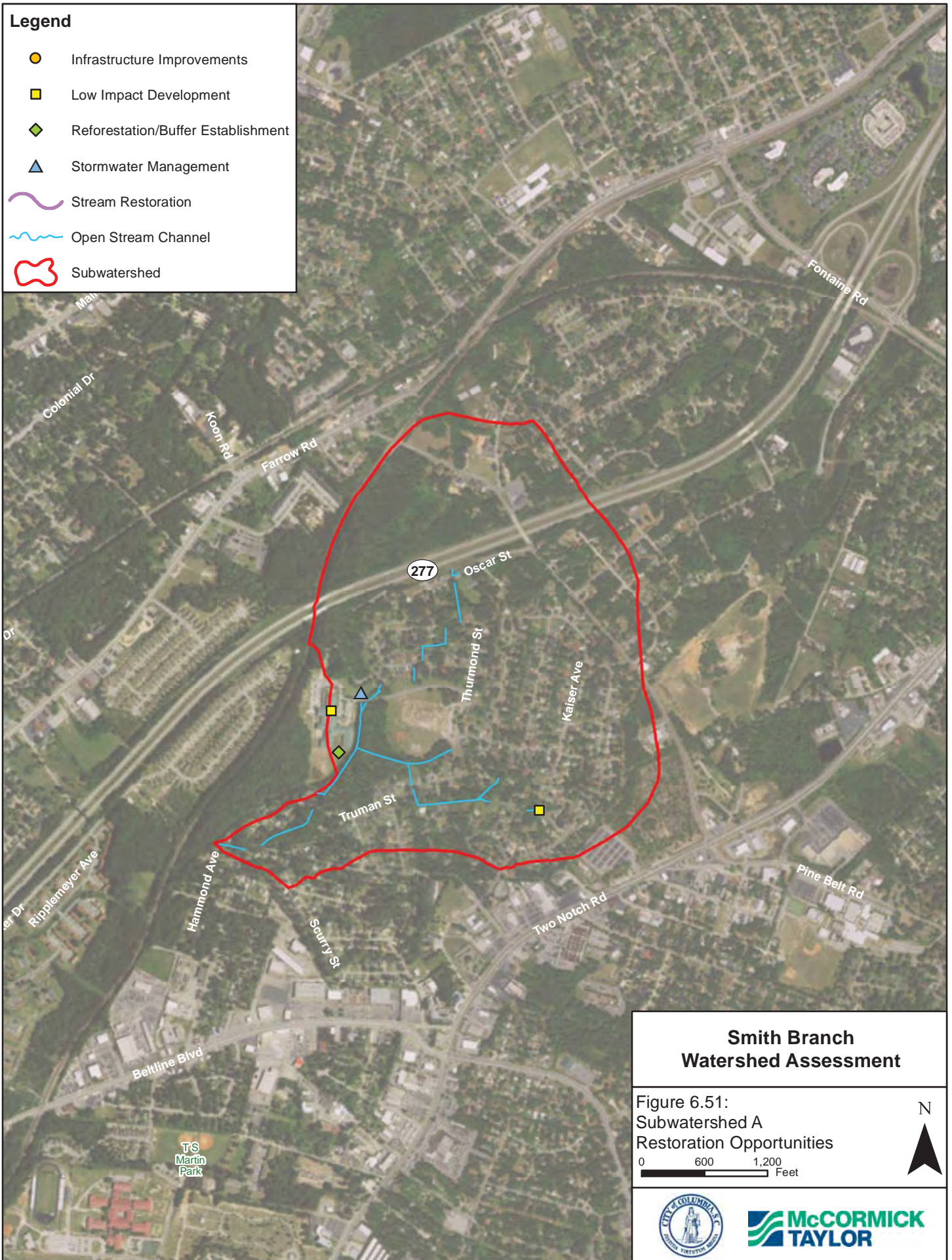
The following projects or similar improvements may be considered to address conditions identified in SW-A. These projects are included in **Figure 6.51**.

#### **Recommended Improvements:**

- As this catchment continues to develop, the development should occur in accordance with the City of Columbia BMP Manual.
- Opportunities for infiltration and storage should be investigated here due to the subwatershed's location on the edge of the watershed draining to Bay Branch.
  - Replace concrete flume west of Kaiser Avenue with rock dissipation/step structure.
  - Build a retention pond to control runoff from SC-277 at Burton-Pack Elementary School and plant trees where feasible.
- Additional mapping of the conveyance system above SC-277 is recommended in order to determine how the water flows from the developed area at the northern end through undeveloped areas to the south side of SC-277.

**Legend**

-  Infrastructure Improvements
-  Low Impact Development
-  Reforestation/Buffer Establishment
-  Stormwater Management
-  Stream Restoration
-  Open Stream Channel
-  Subwatershed



**Smith Branch  
Watershed Assessment**

Figure 6.51:  
Subwatershed A  
Restoration Opportunities

0 600 1,200  
Feet

N



## 6.11 Subwatershed K (SW-K)

### Introduction

#### Setting:

- Subwatershed K (SW-K) is located within the western portion of the Smith Branch watershed.
- The northernmost point is between Wildwood and Hillcrest Avenues, the northern boundary roughly follows Duke Avenue, the eastern boundary along SW-J extends south to Columbia Avenue and the southwest boundary roughly parallels River Drive. The westernmost point is south of the Westwood Avenue and Clement Road intersection.
- 409 acres or 0.64 square miles in drainage area
- Contains 3.90 miles of open stream channel, and 1.77 miles of mapped storm drain/pipe
- Dominant land use designations (**Figure 6.1, Table 6.1**):
  - Developed, Open Space: 36%
  - Developed, Low Intensity: 34%
- Impervious surface cover: 20%



**Figure 6.52**  
**Subwatershed K**

**Soils:** Approximate soil type percentages within SW-K include (refer to **Section 3.4** for soil descriptions and **Figure 6.53** for soil distributions):

- Orangeburg-Urban land complex, 6 to 15% slopes (OgD): 45%
- Orangeburg-Urban land complex, 2 to 6% slopes (OgB): 41%
- Johnston loam (Jo): 10%
- Pelion-Urban land complex, 2 to 10% slopes (PnC): 4%




#### Overview:

SW-K is a large subwatershed located within the western portion of the Smith Branch watershed. SW-K is primarily residential, the largest buildings are Heyward Gibbes Middle School to the northwest and large church along Sunset Drive and associated parking lot, to the south. Residential lots are single-family detached, single-family attached, and multi-family residences. Portions of this subwatershed are forested, specifically surrounding the Smith Branch mainstem corridor

### Existing Conditions

**Figure 6.54** highlights existing conditions that were either captured during the stream cruising effort or developed using GIS data.

**Legend**

-  Open Stream Channel
-  Soils
-  Subwatershed



**Smith Branch  
Watershed Assessment**

Figure 6.53:  
Subwatershed K  
Soils

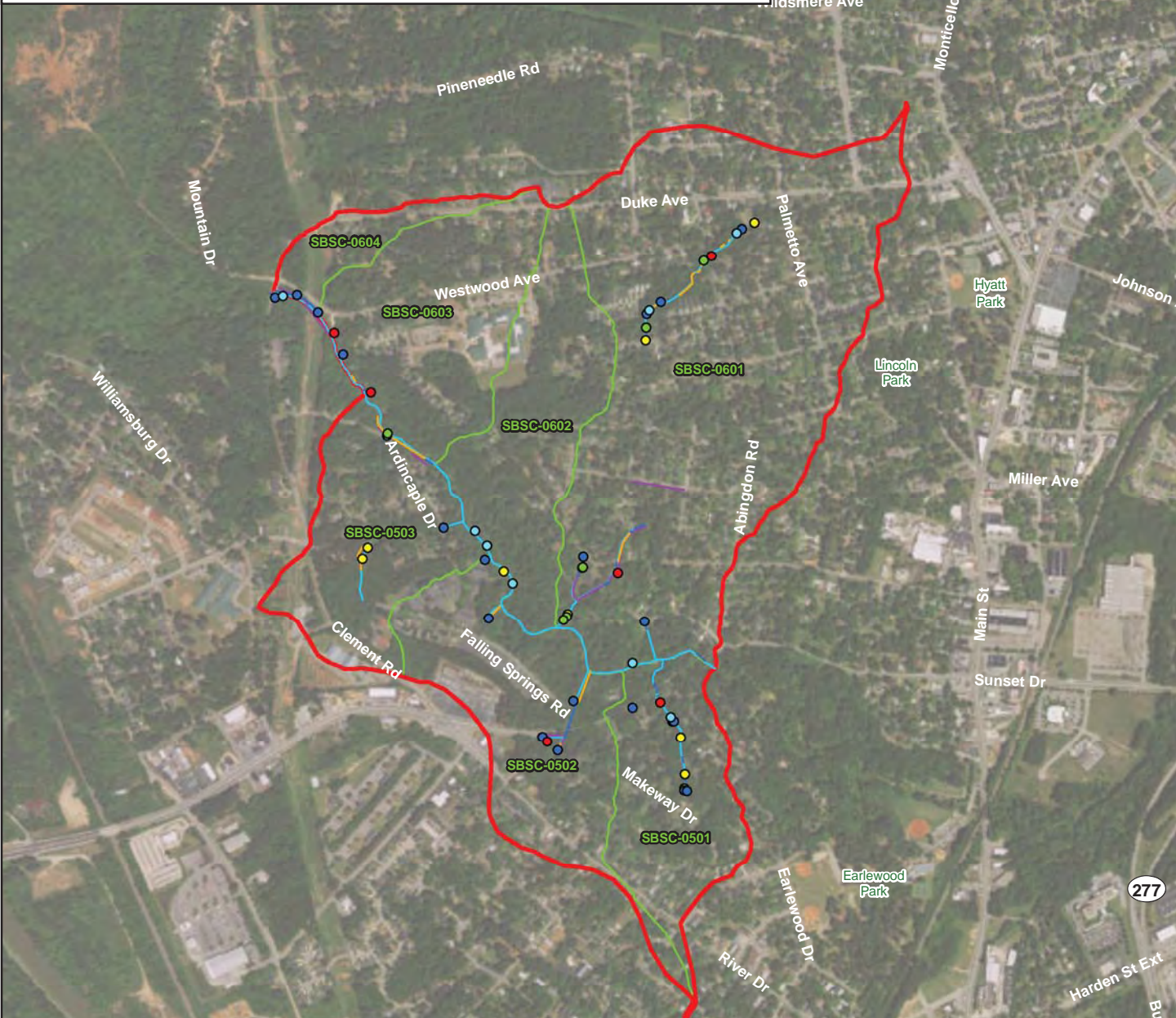
0 600 1,200  
Feet

N



**Legend**

- Trash Dumping
- Unusual Condition
- Inadequate Forest Buffer
- Pipe Outfall
- ~ Open Stream Channel
- SWM Facility
- Possible Fish Barrier
- Erosion Site
- SWMM Subcatchment
- Exposed Pipe
- Channel Alteration
- Subwatershed
- Unmanaged Runoff



Existing Condition	Count
Exposed Pipes	10
Pipe Outfalls	19
Unmanaged Runoff	6
Unusual Condition	10
Trash Dumping	0
Possible Fish Barrier	6
Linear Feet	
Erosion Site	2,912
Channel Alteration	1,674
Inadequate Forest Buffer	4,413

**Smith Branch  
Watershed Assessment**

Figure 6.54:  
Subwatershed K  
Existing Conditions

0      600      1,200

Feet

N

### Channel Conditions:



Within SW-K, the upstream extent of the Smith Branch mainstem channel begins southwest of the Sunset Drive and Summerlea Drive intersection. Smith Branch passes through a 9.8 foot wide by 9 foot high double box culvert under Sunset Drive and enters a forested floodplain parcel between residential communities. There are indications (lateral scour and fine sediment deposition) that suggest a severe meander bend immediately downstream of the Sunset Drive creates a backwater during storm events. This area (specifically the right bank downstream of Sunset

Drive) appears to have been impacted by the flooding in October, 2015. A large section of the right bank at the left turn of the stream appears to have been totally obliterated. Although the catastrophic opening of the channel may actually provide needed energy dissipation, this reach should be reviewed in more detail for bank stabilization given the proximity of residences to the channel.

With the exception of a boulder-field for a distance of approximately 200 feet from the Sunset Drive culvert, the rest of the mainstem channel conditions are relatively similar throughout SW-K. Banks are tall but relatively stable, with thick vegetation on the bank face. Residential property encroaches on the channel along Ardincaple Drive for 500 feet. Both banks are stabilized with riprap for the last 350 feet downstream until the stream passes under Clement Road at the downstream SW-K boundary. Sand is the dominant bed material through this segment, though large outcroppings of boulders and bedrock appear periodically within the upstream limits. Large coarse point bars are present and define baseflow patterns throughout.

Multiple tributaries and outfall channels contribute flow to the Smith Branch mainstem, four of which are significant. The first and easternmost tributary begins from two outfalls northeast of the Westbury Drive and Makeway Drive intersection. The channel extends through two driveway culverts at the upstream end. Banks are low, stable, and well vegetated throughout this segment and bed substrate is primarily sand. The channel is pinned between residential properties; fencing crossing the channel resulted in sediment deposition and blocked flow. Downstream, flow emerges from two 24 inch RCPs underneath a second fence crossing the channel. The stream then extends northwest through a culvert underneath Sunset Drive and into the Smith Branch floodplain. The downstream end of the Sunset Drive culvert is submerged at baseflow. The tributary flows into the Smith Branch mainstem immediately downstream.



The second tributary begins southeast of the Makeway Drive and Sunset Drive intersection. Multiple headcuts have formed throughout the segmented channel network. At the upstream end, south of Sunset Drive, a 15-foot tall headcut is nearing the foundation of a single family home. The stream is then piped under Sunset Drive and Falling Springs Road. Downstream of Falling Springs Road, the channel has downcut and undermined the culvert and an additional



storm drain outfall (discussed further below). The tributary flows into the Smith Branch mainstem approximately 250 feet downstream.

Downstream, the third and largest tributary in SW-K flows into the mainstem from the right bank, southwest of the Avondale Drive and Summerlea Drive intersection. The upstream extent



of open channel along this tributary begins at a 48 inch RCP under Margrave Road near the Duke Avenue intersection. The channel is shallow and vegetated, with channel material consisting of mostly gravel and cobble. The stream extends through a culvert under Abingdon Road. Downstream of the culvert, severe channel incision contributes to bank instability for the majority of this segment, extending downstream to Myles Avenue. Downcutting has undercut trees and exposed bedrock in the bed and at the toe of the 15-foot tall banks. Incision lessens immediately upstream

of Myles Avenue where the banks are lower and more stable with increasing vegetative protection. Bedrock intrusion decreases, as gravel and cobble increases. Before flowing through the culvert under Myles Avenue, the channel is altered, bed and banks are comprised of stacked masonry stone for approximately 100 feet. The channel is then piped from Myles Avenue to the south side of Summerlea Drive. Immediately downstream of Summerlea Drive, the stream is channelized with concrete bed and grouted stone walls extending approximately 150 feet. Downstream of the concrete channel, sandy deposition accounts for the majority of stream bed, with gravel, cobble, and bedrock along the riffles. A small tributary joins the main tributary described above, from the left bank. This additional small tributary starts between residential housing northeast of the Avondale and Hazelnut Road intersection. The small channel is incised with bare banks and moderate bank erosion extends 250 feet upstream of Avondale Drive. The confluence with the Smith Branch mainstem is Approximately 270 feet southeast of the confluence of the two tributaries.

The fourth tributary originates north of the Clement Road and Kensington Road intersection. The upstream end is braided, with wetland-like conditions and isolated areas of erosion. The stream becomes piped south of the Aberdeen Avenue and Ayrshire Avenue intersection, extending east until the stream is daylighted downstream of Ardincaple Drive and joins the Smith Branch mainstem 150 feet downstream.

### *Ecology*

Stream habitat quality within the Smith Branch mainstem in SW-K is generally good. Habitat is quality is more impaired within the tributaries. The Smith Branch mainstem had similar habitat conditions throughout, with common issues being sedimentation, some minor bank instability, and some banks with sparse vegetative protection. The tributary between Westbury and Earlewood Drive has poor habitat quality, with heavy sedimentation, a lack of epifaunal substrate/ available cover, limited velocity/depth regimes and a narrow riparian buffer width. The tributary segment upstream of Abingdon Road is in better condition, with stable banks and established vegetation, though substrates were embedded. Downstream of Abingdon Road, the extreme incision reduces bank stability and limits bank vegetative protection.



Overall, the majority of the stream network in SW-K has a greater than 35 feet riparian buffer, with the exception of a few isolated areas of channel encroachment (approximately 15%).

### Constraints:

- Property Ownership:
  - Overall SW-K Open Channel:
    - Public: 30%
    - Private: 70%
  - Within a 50 Foot Wide Open Channel Buffer:
    - Public: 32%
    - Private: 68%
- Mapped Drainage Network:
  - Drain Pipe: 47%
  - Open Stream Channel: 53%
- 10 longitudinal channel interruptions
- Channel encroachment: private property

### SWM Assessment:

#### *Facilities*

There are no mapped stormwater facilities within SW-K.

#### *Outfalls*

During the field review, a total of 19 storm drain outfalls were identified within SW-K, three of which were rated severe in condition. The first outfall, located southeast the Makeway Drive and Sunset Drive intersection, contributes to an extreme headcut downstream. Vegetation around the pipe is overgrown and there is a four foot vertical drop to the mainstem. The second and third severe outfalls are downstream of Falling Springs Road, where the channel has downcut and undermined the outfalls, disconnecting terminal pipe segments in both outfalls.

#### *SWMM*

SW-K contains suburban development combined with moderate slopes. The 406-acre subwatershed has a below average amount of impervious surface at 20%, the third lowest in the watershed. Based on the SWMM modeling for a 2-year storm event, SW-K produces approximately 0.8 peak cfs/acre, a total runoff volume of 8.2 million gallons, and a runoff volume per area of 2,681 cubic feet/acre, all of which are the third lowest in the watershed. SW-K received a low overall runoff ranking (11) due lesser modeled impairment relative to the other subwatersheds. In addition, SW-K is near the end of the watershed where undeveloped floodplain areas are quite valuable in that they allow natural floodplain access for flood waters without impact to development.

SW-K is modeled in SWMM as six subcatchments (**Figure 6.55**), three on either side of Smith Branch. All of these subcatchments are low in imperviousness, with the highest only nearly 30%. The suburban nature and unencumbered floodplain areas of this watershed should be preserved given the identified problems and needs for flood storage/relief in upstream subcatchments. The relatively low amount of runoff generated here is allowed to flow out of the watershed without exacerbating flooding issues.








**Total Subwatershed Runoff Ranking: 11****Figure 6.55 SW-K SWMM Model****Restoration Opportunities**

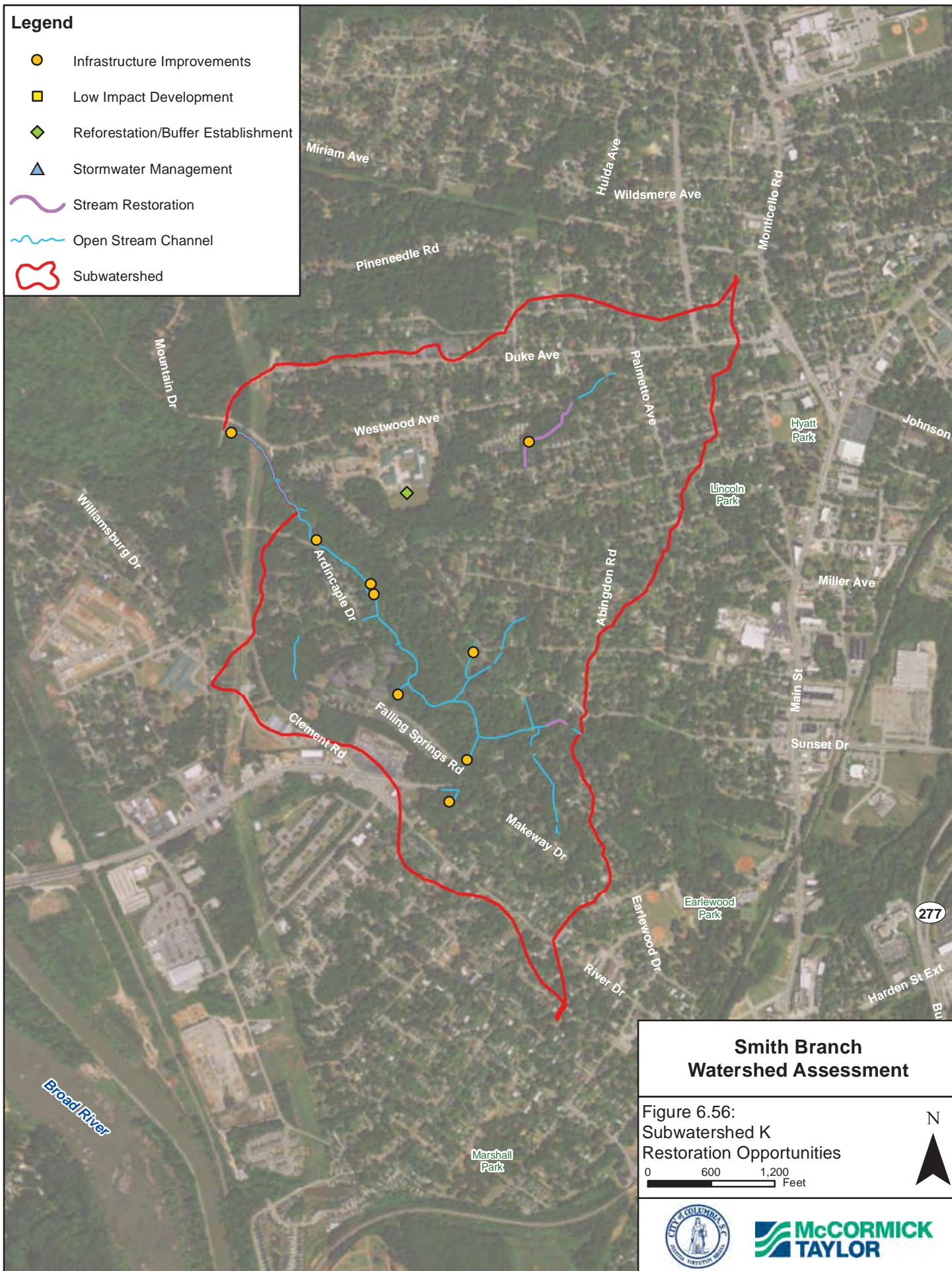
The following projects or similar improvements may be considered to address conditions identified in SW-K. These projects are included in **Figure 6.56**.

**Recommended Improvements:**

- Development in flood-prone areas near Smith Branch should be restricted. In addition, open space floodplains where this catchment is at the bottom of the watershed should be investigated for permanent protection under easements or restrictive covenants.
- Stabilize the outfalls north of Makeway Drive, north of Falling Springs Road, and east of Ardincaple Drive.
- Bank stabilization downstream of Sunset Drive
- Repair the utility lines exposed in the bed north of Myles Avenue, east of Clement Road, and east of Ardincaple Drive.
- Stabilize the banks west of Abingdon Road.
- Plant trees where feasible at Heyward Gibbes Middle School.
- As this catchment continues to develop, the development should occur in accordance with the City of Columbia BMP Manual.

**Legend**

-  Infrastructure Improvements
-  Low Impact Development
-  Reforestation/Buffer Establishment
-  Stormwater Management
-  Stream Restoration
-  Open Stream Channel
-  Subwatershed



## 6.12 Subwatershed L (SW-L)

### Introduction

#### Setting:

- Subwatershed L (SW-L) is located within the western portion of the Smith Branch watershed.
- The easternmost point is between Wildwood and Hillcrest Avenues, Duke Avenue to the south, Mountain Drive is adjacent to the western border, and the intersection of Ryan Avenue and Lakeside Avenue creates the northernmost point
- 299 acres or 0.47 square miles in drainage area
- Contains 2.00 miles of open stream channel, and 1.36 miles of mapped storm drain/pipe
- Dominant land use designations (**Figure 6.1, Table 6.1**):
  - Developed, Low Intensity: 37 %
  - Developed Open Space: 35 %
  - Forest: 26%
- Impervious surface cover: 16%



**Figure 6.57**  
**Subwatershed L**

**Soils:** Approximate soil type percentages within SW-L include (refer to **Section 3.4** for soil descriptions and **Figure 6.58** for soil distributions):

- Orangeburg-Urban land complex, 6 to 15% slopes (OgD): 57%
- Orangeburg-Urban land complex, 2 to 6% slopes (OgB): 42%
- Chastain silty clay loam (Cd): 1%
- Johnston loam (Jo): 1%




#### Overview:

SW-L is the northwestern most subwatershed within the Smith Branch watershed. The area is primarily residential and includes 26% forest, the second highest subwatershed forest coverage. The building with the largest footprint in SW-L is the Kingdom Hall of Jehovah's Witnesses building and its associating parking lot, adjacent to the Duke Avenue, Ronnie Street intersection. A large overhead utility line and right of way extends north south near the western boundary of SW-L.

### Existing Conditions

**Figure 6.59** highlights existing conditions that were either captured during the stream cruising effort or developed using GIS data.

**Legend**

-  Open Stream Channel
-  Soils
-  Subwatershed



**Legend**

- Trash Dumping
- Unusual Condition
- Inadequate Forest Buffer
- Pipe Outfall
- ~ Open Stream Channel
- SWM Facility
- Possible Fish Barrier
- Erosion Site
- SWMM Subcatchment
- Exposed Pipe
- Channel Alteration
- Subwatershed
- Unmanaged Runoff



Existing Condition	Count
Exposed Pipes	8
Pipe Outfalls	17
Unmanaged Runoff	5
Unusual Condition	10
Trash Dumping	3
Possible Fish Barrier	6
	<b>Linear Feet</b>
Erosion Site	9,534
Channel Alteration	843
Inadequate Forest Buffer	3,515

**Smith Branch  
Watershed Assessment**

Figure 6.59:  
Subwatershed L  
Existing Conditions



### Channel Conditions:



Upstream limits of the open channel network within SW-L begin between Steadham and Wildwood Avenue, west of Palmetto Avenue. Banks are low, stable, and well vegetated. Channel substrate is primarily sand, with gravel and cobble along riffles. The left bank is stabilized with a brick wall upstream of the Abingdon Road crossing. After the stream extends under Abingdon Road, the channel becomes deeply incised extending within a cleared utility right of way; raw vertical banks threaten infrastructure and private property on both sides. Bedrock intrusion

dominates the channel substrate. There is a confluence point with a significant along the left bank approximately 540 feet downstream of Abingdon Road.

The tributary originates from three outfalls west of Hulda Avenue. Unmanaged runoff has caused rills to form along the right bank near single-family residences and the channel becomes incised downstream; the 7-foot tall banks are stable and well vegetated with isolated areas of erosion. Downstream, the stream extends through a culvert under Wildsmere Avenue. The 36 inch RCP culvert shows significant degradation as the pipe segments do not appear to be connected and erosion has degraded the upstream end. Incision continues downstream of Wildsmere Avenue, exposing bedrock in the bed and at the toe of the banks. Approximately 360 feet downstream of the Wildsmere Avenue crossing, the tributary merges with the main receiving channel described in the paragraph above.



Downstream of the confluence of the two tributaries previously described, the channel incision continues, with 6 to 8 foot banks. Downtcutting into bedrock has created a series of steep cascades with large scour pools downstream. Substrate in this segment is mainly bedrock with sand in the pools and gravel and cobble along the riffles. The stream then extends through a 42 inch road culvert under Woodridge Drive.



In the wooded area between Woodridge Drive and Brookridge Drive, two small tributaries converge with the main receiving tributary described above. The first tributary originates from an outfall north of Glenn Avenue, and the second tributary from an outfall south of Brookridge Drive. The stream from Glenn Avenue has been straightened and channelized, extending through multiple driveway culverts and under Glenn Avenue and Woodridge Drive before its confluence with the main tributary. The second tributary is a small incised channel that flows south from the northern



extent of Brookridge Drive through a forest buffer between single-family residences before its confluence with the main channel.

Downstream of the confluence, the main tributary channel extends through culverts under Brookridge Drive and Pineneedle Road. The banks around the culverts have been recently repaired with riprap, but the upstream side of the Brookridge Drive crossing is over 50% filled with sediment. Downstream of the Pineneedle Road crossing, the main tributary receives flow from another tributary originating within a forested area east Woodridge Drive. Substrate within this tributary is primarily sand, with gravel and cobble along the riffles. The channel is incised, with portions of both banks raw and actively eroding. The tributary extends under Woodridge Drive before flowing between residential properties and converging with the main tributary channel.

Incision down to bedrock exposure resumes in the main channel downstream of the confluence mentioned above. The stream crosses a large cleared utility right of way, where downcutting has exposed multiple utility lines within the bed. Banks become lower, well vegetated and stable approximately 350 feet downstream of the right of way. Substrate dominance shifts from bedrock to sand. The stream then extends under Mountain Drive through a 48 inch road culvert. Although the upstream face of the culvert has been recently stabilized with riprap, there is slumping around and above the pipe and the pipe itself shows signs of degradation. At the southern end of the subwatershed, the tributary converges with the Smith Branch mainstem. It appears likely that incision of these streams is endemic, however, the October 2015 flood event exacerbated more channel erosion and is evident by a large splay deposition of sands and gravels prior to the confluence with Smith Branch at Mountain Road.



### *Ecology*

Stream habitat quality within SW-L reflects the overall incised nature of the open stream channels within this subwatershed. At the upstream end, bank stability is poor, there is little vegetative protection on the bank faces and epifaunal substrate/available cover is generally lacking because of the prominence of bedrock as bed material. The stream segment between Hulda Avenue and Wildsmere Avenue has more stable banks, better vegetative protection, and more frequent riffles. Downstream, the incised conditions continue with fair habitat quality. The stream segment from west of Mildred Avenue to the confluence south of Pineneedle Road has good epifaunal substrate/available cover and suboptimal vegetative protection. Downstream of the confluence south of Pineneedle Road, the main tributary channel continues to be incised, with raw unstable banks, little vegetative protection, excessive sediment deposition, and marginal epifaunal substrate/available cover. Habitat quality improves downstream of the utility right of way; banks become more stable and well vegetated, though sediment deposition is still high.

The stream channel network generally had an adequate riparian vegetated buffer, with exceptions being segments adjacent to or through utility right of ways and channel encroachment adjacent residential parcels (approximately 20%).

**Constraints:**

- Property Ownership:
  - Overall SW-L Open Channel:
    - Public: 12%
    - Private: 88%
  - Within a 50 Foot Wide Open Channel Buffer:
    - Public: 14%
    - Private: 86%
- Mapped Drainage Network:
  - Drain Pipe: 40%
  - Open Stream Channel: 60%
- Twelve longitudinal channel interruptions
- Channel encroachment: private property, utility lines and right of ways

**SWM Assessment:***Facilities*

There are no mapped stormwater facilities within SW-L.

*Outfalls*

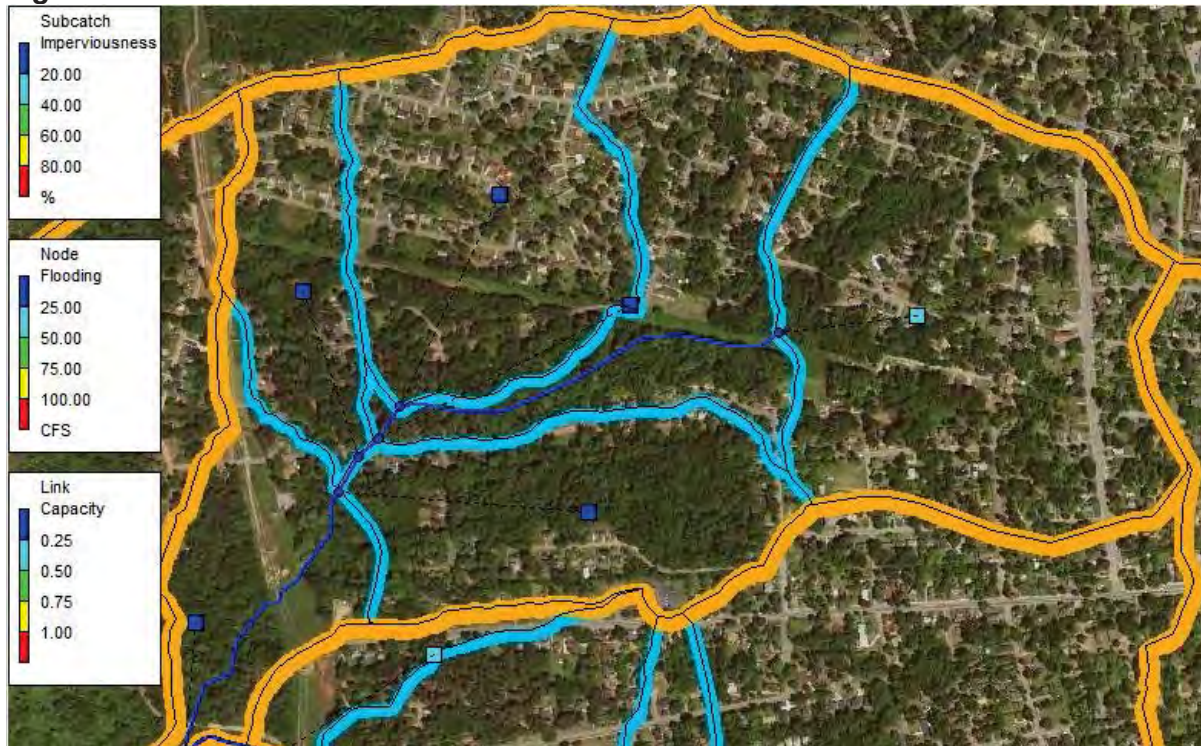
During the field review, a total of 17 stormwater outfalls were identified within SW-L, all of which were rated in minor to moderate condition.

*SWMM*

SW-L is one of the least developed subwatersheds and contains primarily neighborhoods with relatively high slopes. The 299-acre subwatershed has the second lowest amount of impervious surface at 15.7%. Based on the SWMM modeling for a 2-year storm event, SW-L would produce approximately 0.8 peak cfs/acre, the total runoff volume predicted is 4.8 million gallons, and the runoff volume per area is 2,153 cubic feet/acre, all of which are the second lowest for the watershed. SW-L drains to a tributary to Smith Branch in its center and then south to the Smith Branch mainstem. In the southern portions of SW-L, the streams have not been encroached upon by development. SW-L received the second lowest overall runoff ranking due to its low level of runoff impairment compared to the rest of the watershed. It is near the downstream limit of the watershed where undeveloped floodplain areas are most valuable.

SW-L is modeled in SWMM as six subcatchments (**Figure 6.60**), with five of them contributing flows directly to a tributary in the center of it. All of these subcatchments are low in imperviousness, with the highest only about 23%. Due to its location at the downstream limit of Smith Branch, the relatively low amount of runoff generated here is allowed to flow out of the watershed without exacerbating flooding issues.

**Total Subwatershed Runoff Ranking: 12**

**Figure 6.60 SW-L SWMM Model**








### **Restoration Opportunities**

The following projects or similar improvements may be considered to address conditions identified in SW-L. These projects are included in **Figure 6.61**.

#### **Recommended Improvements:**

- Development in flood-prone areas near Smith Branch should be restricted. In addition, open space floodplains at the bottom of the watershed should be investigated for permanent protection under easements or restrictive covenants.
- Preserve or restore as needed the remaining natural stream channels in this subwatershed.
- Repair the utility lines exposed in the stream bed south of Pineneedle Road, south of Euclid Avenue, and within the utility right of way crossing.
- Stabilize the banks south of Wildsmere Avenue and the culvert north of Wildsmere Avenue.
- Replace the culvert at the Brookridge Drive crossing and stabilize the culvert at the Mountain Drive crossing.
- As this catchment continues to develop, the development should occur in accordance with the City of Columbia BMP Manual.

**Legend**

-  Infrastructure Improvements
-  Low Impact Development
-  Reforestation/Buffer Establishment
-  Stormwater Management
-  Stream Restoration
-  Open Stream Channel
-  Subwatershed



**Smith Branch  
Watershed Assessment**

Figure 6.61:  
Subwatershed L  
Restoration Opportunities

0 600 1,200 Feet

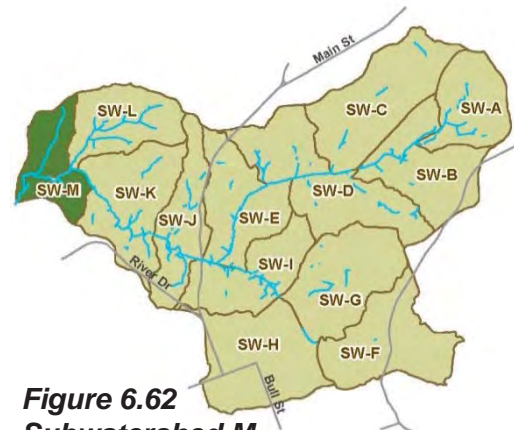


## 6.13 Subwatershed M (SW-M)

### Introduction

#### Setting:

- Subwatershed M (SW-M) is the westernmost subwatershed within the Smith Branch watershed.
- The northernmost point is located at Revel Stoke Drive, Mountain Drive roughly parallels the eastern boundary, Wellesley Drive to the south, and the Broad River to the west.
- 230 acres or 0.36 square miles in drainage area
- Contains 1.57 miles of open stream channel, and 0.02 miles of mapped storm drain/pipe
- Dominant land use designations (**Figure 6.1, Table 6.1**):
  - Forest: 45%
  - Herbaceous: 19%
- Impervious surface cover: 7%



**Figure 6.62**  
**Subwatershed M**

**Soils:** Approximate soil type percentages within SW-M include (refer to **Section 3.4** for soil descriptions and **Figure 6.63** for soil distributions):

- Orangeburg-Urban land complex, 6 to 15% slopes (OgD): 40%
- (ObB): 20%
- Orangeburg-Urban land complex, 2 to 6% slopes (OgB): 17%
- Chastain silty clay loam (Cd): 17%
- Johnston loam (Jo): 3%
- Wedowee loamy sand, 10 to 30% slopes (WeE): 2%
- Nason complex, 10 to 30% slopes (NaE): 1%




#### Overview:

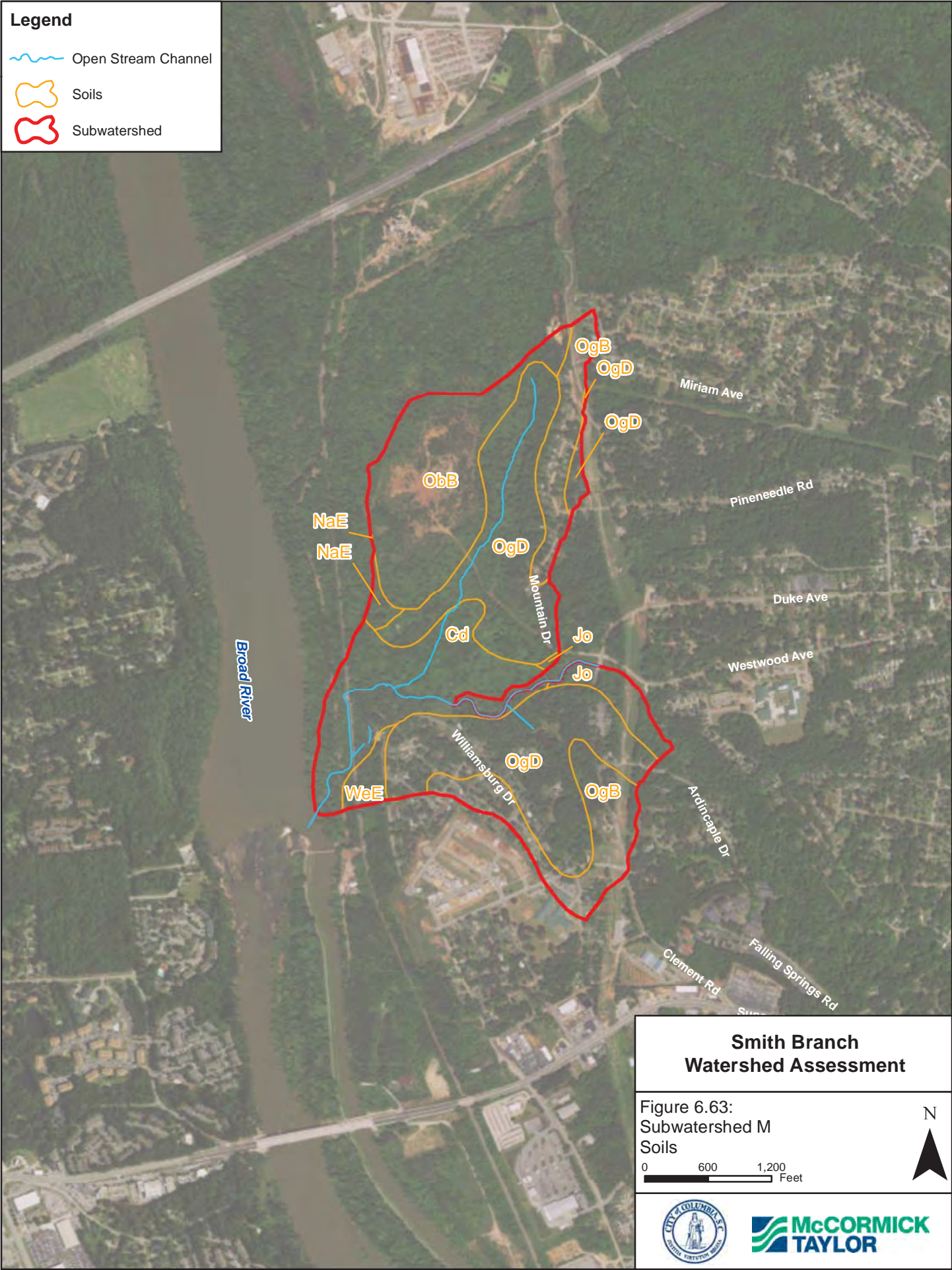
SW-M is the westernmost and least developed subwatershed within the Smith Branch watershed. Small pockets of residential development exists on the eastern and southern borders. The remainder of the subwatershed is forested.

### Existing Conditions

**Figure 6.64** highlights existing conditions that were either captured during the stream cruising effort or developed using GIS data.

**Legend**

-  Open Stream Channel
-  Soils
-  Subwatershed



**Smith Branch  
Watershed Assessment**

Figure 6.63:  
Subwatershed M  
Soils

0 600 1,200  
Feet

N



**Legend**

- Trash Dumping
- Unusual Condition
- Inadequate Forest Buffer
- Pipe Outfall
- ~ Open Stream Channel
- SWM Facility
- Possible Fish Barrier
- Erosion Site
- SWMM Subcatchment
- Exposed Pipe
- Channel Alteration
- Subwatershed
- Unmanaged Runoff



**Smith Branch  
Watershed Assessment**

Figure 6.64:  
Subwatershed M  
Existing Conditions



Existing Condition	Count
Exposed Pipes	0
Pipe Outfalls	6
Unmanaged Runoff	0
Unusual Condition	1
Trash Dumping	0
Possible Fish Barrier	0
	<b>Linear Feet</b>
Erosion Site	2,255
Channel Alteration	226
Inadequate Forest Buffer	532



### Channel Conditions:



Within SW-M, the Smith Branch mainstem begins at the subwatershed's eastern most boundary from a bridge crossing at Clement Road. Riprap and gabion baskets have been placed on the right bank to mitigate severe bank erosion that has endangered Mountain Drive. Downstream of the riprap, the right bank is severely eroded, slumping into the bed and migrating towards Mountain Drive. A large coarse point bar has formed on the left bank. Downstream, a large debris jam at the confluence with the major tributary from SW-L has obstructed flow, resulting in flanking and scour around the obstruction on the left bank. Substrate consists of mostly sand, with significant quantities of cobble and gravel along the riffles and point bars. Erosional activity continues downstream, impacting the outside of bends. Large depositional bars have formed on the inside of bends. A small tributary originating from a pond outfall contributes flow from the left bank. As the channel approaches Williamsburg Drive, another significant debris jam obstructs flow, storing large amounts of fine sediment upstream of the obstruction. Downstream of the debris jam, the 40-foot tall left bank becomes raw, with no vegetation on the bank face or at the top of the bank. As the channel moves away from Williamsburg Drive, banks stabilize. Cobble and gravel quantities diminish within the bed. A significant tributary that runs roughly parallel to Mountain Drive joins the Smith Branch mainstem north of Williamsburg Drive. The channel then passes under a railroad, turning sharply south where it is confined between the railroad trestle on the left and an access road on the right. Backwater from the Broad River and associated dam influences the channel from this point to the confluence with the Broad River.

A large tributary within SW-M flows southwest to the mainstem through a forested parcel along Mountain Drive, beginning approximately 350 feet west of Miriam Avenue. The upstream extent of the tributary is a braided headwater system. A seep evolves into an established perennial stream as it flows downstream. Substrate consists of mostly clay within the bed. Approximately 2,000 feet downstream from the headwaters, a gravel access road has dammed the stream, causing the single-thread channel to be inundated by ponded water upstream of the crossing and filled by deposited sediments downstream. A second access road cuts through the stream channel approximately 450 feet downstream, interrupting flow. Downstream of the access roads, the stream continues as braided and lacks clear bank definition. The channel becomes more established near the confluence with the Smith Branch mainstem.



### Ecology

Stream habitat quality ranges from fair to good within SW-M. The Smith Branch mainstem between Clement Road and the confluence with the headwater tributary from the north is impacted by bank instability and heavy sedimentation. Downstream of the tributary, Smith Branch is influenced by the backwater from the Broad River and dam. This segment is



characterized by deep, slow waters, heavy sedimentation, and little bed diversity. The tributary parallel to Mountain Drive exhibits headwater conditions, with heavy sedimentation as a result of the access roads, and shallow slow waters. The small tributary leading from the pond near Clement Road has generally good habitat, with some sedimentation and a lack of diversity in velocity/depth regimes. Excluding occasional isolated areas of channel encroachment (approximately five percent), the channel network in SW-M has an adequate riparian vegetated buffer.

**Constraints:**

- Property Ownership:
  - Overall SW-M Open Channel:
    - Public: 8%
    - Private: 92%
  - Within a 50 Foot Wide Open Channel Buffer:
    - Public: 8%
    - Private: 92%
- Mapped Drainage Network:
  - Drain Pipe: 1%
  - Open Stream Channel: 99%
- There are two longitudinal channel interruptions
- Channel encroachment: railroad, access roads east of Mountain Drive

**SWM Assessment:**

*Facilities*

One large stormwater facility was mapped within SW-M, located along the railroad in the western portion of the subwatershed.

*Outfalls*

During the field review, a total of six outfalls were identified within SW-M, all of which were rated in minor to moderate condition, with the exception of one structure. The 24 inch CMP outfall located within the downstream embankment of an unmapped pond between Clement Road and Williamsburg Drive was rated very severe. The end of pipe is undermined and headcut progression threatens the pond embankment.

*SWMM*

SW-M is the smallest subwatershed in the Smith Branch Watershed at 230 acres. SW-M has the lowest amount of impervious surface as well at 6.7%. SW-M also has the lowest peak discharge per area, total runoff, and runoff per area in the watershed according to the results from the 2-year event simulated in SWMM (0.4 peak cfs/acre, 1.8 million gallons, and 1,068 cubic feet/acre, respectively). This primarily undeveloped subwatershed is forested in the north, and then drains to a tributary in the middle that drains south into Smith Branch. The land use transitions to suburban residential in the south. As this subwatershed faces additional development pressure, attention must be given to ensure that the existing streams are protected and that adequate stormwater control measures are installed to protect Smith Branch.



SW-M is modeled in SWMM as four subcatchments contributing flows directly to Smith Branch (**Figure 6.65**). It is almost entirely undeveloped north of Smith Branch. There is a small amount of suburban development right above the outfall of Smith Branch. The relatively small flows from this watershed are allowed to flow out of Smith Branch without exacerbating flooding issues.

### Total Subwatershed Runoff Ranking: 13

**Figure 6.65 SW-M SWMM Model**



### Restoration Opportunities

The following projects or similar improvements may be considered to address conditions identified in SW-M. These projects are included in **Figure 6.66**.








#### **Recommended Improvements:**

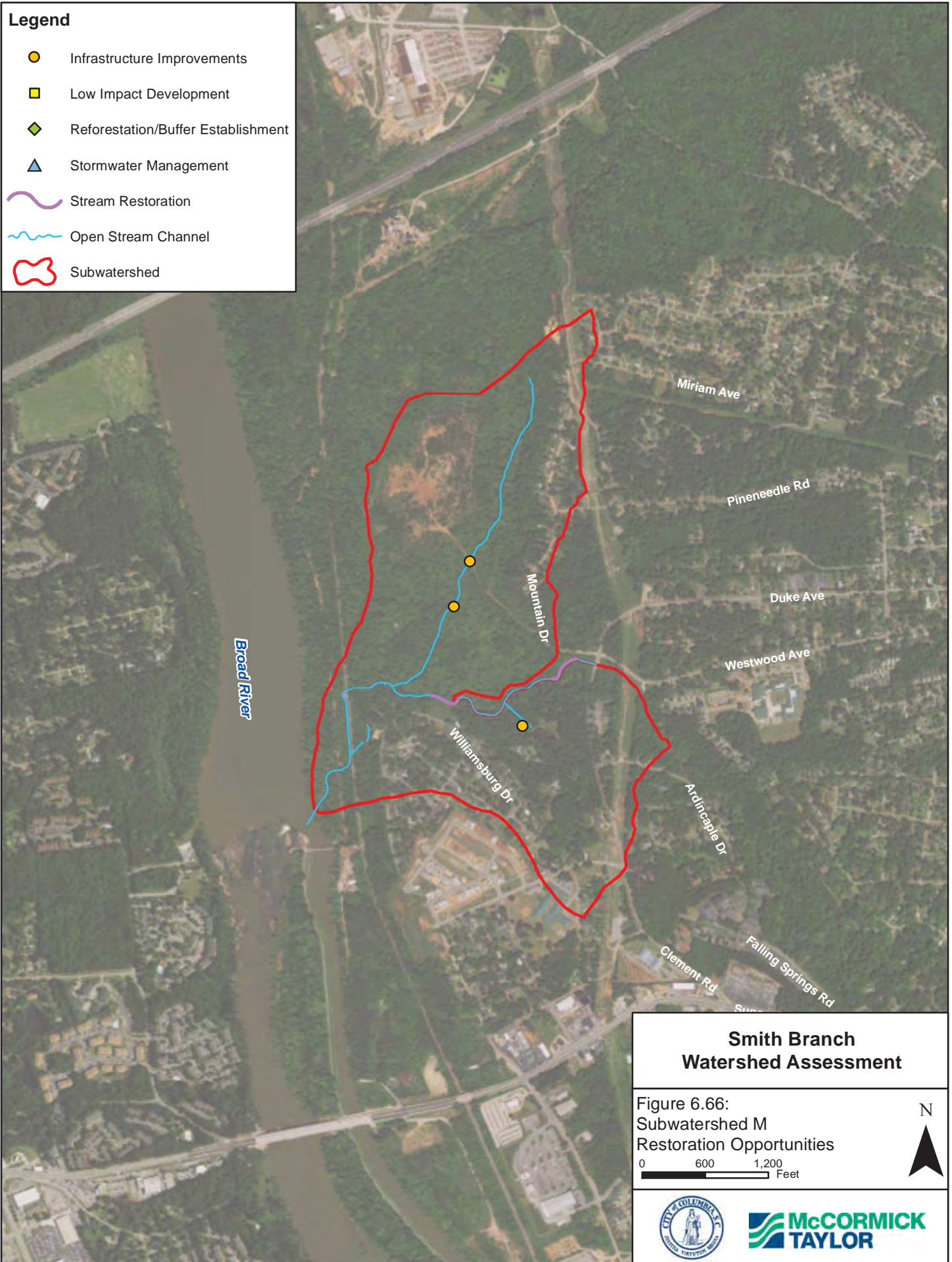
- Development in flood-prone areas near Smith Branch should be restricted. In addition, open space floodplains at the bottom of the watershed should be investigated for permanent protection under easements or restrictive covenants.
- Preserve or restore as needed the remaining natural stream channels in this subwatershed.
- Insert culverts within the access roads currently blocking the tributary that runs parallel to Mountain Drive.
- Stabilize the outfall from the pond west of Clement Road.



- Stabilize the banks south of Mountain Drive and north of Williamsburg Drive.
- As this catchment continues to develop, the development should occur in accordance with the City of Columbia BMP Manual.

**Legend**

-  Infrastructure Improvements
-  Low Impact Development
-  Reforestation/Buffer Establishment
-  Stormwater Management
-  Stream Restoration
-  Open Stream Channel
-  Subwatershed



**Smith Branch  
Watershed Assessment**

Figure 6.66:  
Subwatershed M  
Restoration Opportunities

0 600 1,200  
Feet

N





## 7.0 Restoration Strategies

This chapter presents an overview of the key restoration strategies proposed for improving the water quality and flood-prone conditions of the Smith Branch watershed. A complete list of actions proposed for the watersheds including goals and objectives targeted, performance measures, and cost estimates is included in **Section 8.0**. Although only key, quantifiable restoration strategies are the focus of this chapter, it is important to remember that a combination and variety of restoration practices, from capital stream restoration projects or stormwater BMP retrofits, to public education and outreach, are needed to engage citizens and meet watershed-based goals and objectives.

The restoration of the Smith Branch watershed will occur as a partnership between the local government (City of Columbia and Richland County), watershed groups (Sustainable Midlands and the Smith Branch Watershed Alliance), businesses, and citizens. The actions of each partner are critical to the success of the overall watershed restoration strategy. Local governments are able to implement large capital projects such as culvert/bridge replacements, large-scale stormwater retrofits, stream restoration, changes in municipal operations, and large-scale public awareness. Watershed groups and citizens are able to implement locally-based programs such as tree plantings, storm drain marking, and downspout disconnection. Therefore, key restoration strategies are divided into two broad categories: municipal and institutional strategies (**Section 7.1**) and citizen-based strategies (**Section 7.2**). It is important that restoration occurs at all levels to ensure that a wide range and variety of projects is implemented. This will encourage citizen participation and awareness, which is also critical to the success of restoration efforts.

### 7.1 *Municipal and Institutional Strategies*

The City of Columbia and Richland County are actively working to improve the conditions of their watersheds, receiving streams and improve water quality through capital improvement projects and municipal management activities (e.g. development review, buffer zone implementation, sanitary sewer upgrades, etc.). This plays an important role in the application of this Integrated Watershed Management Plan implementation process. Key municipal strategies proposed for improving the conditions of the Smith Branch Watershed are discussed in the following sections.

Increased importance of water quality and water resource protection has led to the development of the 2014 City of Columbia Best Management Practice (BMP) Design Manual, which provided BMP design standards and environmental incentives. Although currently under a TMDL for fecal coliform, Smith Branch is considered a vital water resource for the City and because of this has additional criteria which have to be met. The additional water quality criteria for this watershed include the following items:

- All sites which disturb greater than one acre shall have a post construction water quality BMP in place to treat at least the runoff from the entire site for a 1.2 inch rainfall event.
- All sites which disturb greater than one acre shall have a post construction channel protection volume (CPv) BMP in place to treat at least the runoff from the entire site for a 1-year storm event.
- Pretreatment device shall be provided prior to any BMP



- Developments with commercial land use or a parking lot which exceeds 2,000 square feet must include the ability to capture hydrocarbons either in pretreatment or in the main BMP.
- If it is impractical to route all impervious areas to a BMP, an exemption may be sought, however, the volume must still be stored within the facility.
- All discharge points shall include energy dissipation features.

Additional details on these increased water quality criteria may be found within the 2014 Design Manual, Section 1.2.3 Critical Water Bodies. Additionally, if the site discharges to an impaired water body that is on SCDHEC's 303(d) list additional measures must be taken. For sites less than 25 acres, evaluation of the BMPs chosen to control pollution must be provided. For sites greater than 25 acres, a comprehensive quantitative and qualitative analysis must be provided. This would include determining the sites pollutant loading, effectiveness of the chosen BMPs and insurance that runoff discharged through the last water quality BMP has a water quality level equal to or better than the in-stream standard.

The 2014 guidelines reflect the general shift towards adopting low-impact practices that mimic natural hydrologic processes and achieve pre-development conditions. The 2014 City of Columbia Best Management Practice (BMP) Design Manual takes those principles one step further through the implementation of Better Site Planning to the maximum extent practicable via nonstructural BMPs and/or other better site design techniques. The intent of better site planning is to distribute flow throughout a development site and reduce stormwater runoff leaving the site. This will also reduce pollutant loads and prevent stream channel erosion.

All development within the City that require a land disturbing permit are required to provide water quality BMPs to treat either the 0.60 inch rainfall event for wet pools or the 1.2 inch rainfall event for BMPS without a permanent pool. Additionally Overbank Flood Protection requires that the post development 2-year and 10-year, 24 hour storm peak discharge rates do not exceed pre-development conditions. For sites over 40 acres, 25-year peak management is required. Watersheds that experience flooding may have additional requirements placed on them such as reducing the post development peak discharge to 50% of the pre-development rates, establishment of 100-year flood plain restrictions or a detailed analysis to determine the impact on the altered timing of the stormwater discharges. 100-year, Extreme Flood Protection is required in to be considered in all cases.

Existing stormwater management facilities within the watershed appear to be limited. During the stream cruise approximately seven facilities were located. These facilities were generally dry detention basins. Water quality benefit from these types of facilities is limited and not ideal. Underground facilities may be present within the watershed but were not able to be field identified.

### 7.1.1 Stormwater Retrofits

Stormwater retrofits involve implementing BMPs in existing developed areas where SWM practices do not currently exist to help improve water quality. Stormwater retrofits improve water quality by capturing and treating runoff before it reaches receiving water bodies. Based on initial field and desktop evaluations, there are many sites with sufficient space for stormwater retrofits to treat runoff from buildings, athletic fields, residential areas, impervious parking lots or roadways. Retrofits may only consist of water quality treatment, or include channel protection, 2-year, or even larger peak discharge management. The type of retrofit is dependent



upon the available space, type of property, and cost limitations. In considering the type of retrofit, consideration to the affect it will have on the timing of the peak along Smith Branch should be considered. While there is a benefit to delay the upland area peak so that it may fall behind the lower main stem peak, if implementation of retrofit BMPs within the lower basin subwatersheds result in a delayed peak, flooding may actually be worsened. Retrofit sites were located in all four upland components surveyed: neighborhoods, publicly owned, institutions, and commercial areas as well as each subwatershed. This study has grouped retrofit opportunities into five categories:

1. Low Impact Design (LID)
2. SWM Facility
3. Stream Restoration
4. Reforestation/Buffer Establishment
5. Infrastructure Improvement

#### **7.1.1.1 Low Impact Design**

##### **7.1.1.1.1 Impervious Cover Removal**

Impervious surfaces include roadways, parking lots, roofs, and other paved surfaces that prevent precipitation from naturally seeping into the ground. As a result, impervious surface runoff can result in erosion, flooding, habitat destruction, and increased pollutant loads to receiving water bodies. Subwatersheds with higher amounts of impervious cover are more likely to have degraded stream systems and contribute significantly to water quality problems in a watershed. Removing impervious cover and converting to pervious or forested land promotes infiltration of runoff and reduces pollutant loads. Unused or unmaintained impervious surfaces with the potential for removal were identified at several institutions, mostly on school properties. The areas of these impervious surfaces were used to estimate potential pollutant load reductions as a result of impervious cover removal activities.

##### **7.1.1.1.2 Bioretention and Rain Gardens**

These facilities have many water quality benefits such as filtration of pollutants from runoff, recharging groundwater supply, and reducing total runoff and flooding potential. Bioretention and Rain Garden facilities are shallow basins that utilize engineered soil media and vegetation to reduce contaminants through filtration and infiltration. Additionally, due to the detention time within these facilities, they provide peak management control for smaller storm events such as the two year, and possibly ten year storms. They also provide beautification of yards, attract and provide habitat for pollinators and birds,



and do not require mowing. This type of BMP is often used in green street applications, and are placed just upstream of existing drainage structures to intercept roadway runoff. Given the large presence of Institutional, commercial and industrial infrastructure within the Smith Branch Watershed, these facilities are an attractive and potentially largely beneficial practice for Smith Branch that should be strongly considered.

#### **7.1.1.1.3 Green Roofs**

Green Roofs have many water quality benefits such as filtration of pollutants from runoff and reducing total runoff and flooding potential. Vegetated green roofs can help mitigate this problem by retaining storm water, keeping an average 56% of annual rainfall from running off roofs and detaining the rest, slowing it's progression into the storm water system. Recent advances in green roof design include modular systems that allow for the retrofit of existing roofs and advancements in vegetation selection and irrigation to ensure survivability throughout the year.

Green roofs have other benefits as well such as reducing the urban heat island affect, filtering the air moving across them, and providing habitat for birds and insects.

Given the large presence of institutional, commercial and industrial infrastructure within the Smith Branch Watershed, Green Roofs are an attractive and potentially largely beneficial practice for Smith Branch that should be strongly considered.

#### **7.1.1.1.4 Green Streets**

Green Streets are roadways that are designed to reduce and filter stormwater runoff. The benefits of green streets are that they can be utilized in areas where there is not enough open space for larger traditional stormwater practices. Green streets use LID techniques such as bioretention BMPs, tree box filters, and pervious surfaces that are constructed within the street right of ways while utilizing existing drainage infrastructure. Green streets can be coupled with roadway maintenance or utility projects or act as stand-alone projects. The green street methodology can be applied to parking lots as well. Micro stormwater facilities can be installed in parking islands and along the perimeter of the lot. To acquire additional space for these facilities, parking lots may be restriped to reduce the required foot print, but allow for the same number of spaces by using diagonal parking with one way parking aisles.



#### **7.1.1.1.5 Boulevard Approach**

This approach entails the placement of street trees with an associated underground stormwater detention system that will store roadway runoff but also allow void space for the tree's roots to grow. This detention system would be placed under the sidewalk, with an inlet to allow

interception of runoff. The detention system would be comprised of a subsurface plastic support system, such as “Storm Tank Urban Root System” or an equivalent product. This system would support the weight of the surface and any loads applied to the surface, while providing void space filled with uncompacted soil. The soil would promote root growth and tree health. Additional units may be left unfilled along the outer perimeter to provide increased storage.

#### **7.1.1.1.6 Rain Harvesting (Cisterns)**

Over the last century, impervious surfaces like concrete, asphalt and roofing materials have been diverting natural rainwater absorption from developed areas and begun depletion of the local underground aquifers. By capturing as much rainfall as possible from buildings and structures, that water may be used to irrigate landscaping, wash vehicles, or other non-potable water uses such as high volume alternating current (HVAC) cooling water. Cisterns may be large underground tanks sized to collect and store roof discharge from multiple buildings, or small stand-alone barrels intended to collect runoff from residential roofs. Cisterns are well suited to academic institutions or municipal properties as guidelines may be easily enforced on the operation and maintenance of these systems. The areas of these impervious surfaces collected can be used to estimate potential pollutant load reductions as a result of cistern installation.

#### **7.1.1.2 Stormwater Management Facilities**

Due to the urban nature of Smith Branch’s watershed, opportunities for traditional structural stormwater management facilities are limited. Traditional stormwater management facilities include underground stormwater detention facilities, detention/retention ponds, above and below ground sand filters. The underground facilities are well suited for parking lots or athletic fields as they do not impact the usable space. There are a multitude of proprietary underground storage systems that provide for easy construction. Above ground sand filters could be placed along parking lot perimeters. Large detention basins can be multi-use facilities that during dry periods serve as an athletic field or open space, while providing storage during rain events.



#### **7.1.1.3 Stream Restoration**

Stream restoration practices are used to enhance the aquatic function, appearance, and stability of stream corridors. Stream restoration practices can range from routine, simple stream repairs such as vegetative bank stabilization and localized grade control to comprehensive repairs such as full channel redesign and realignment. Stream cruising efforts performed in the Smith Branch watershed identified restoration opportunities for stream repair and buffer reforestation. Lengths of eroded and altered channel segments were recorded during the stream cruising effort.



Stabilizing the stream channel improves water quality by preventing soil and the pollutants contained in it, from eroding into the stream and receiving waters.

#### **7.1.1.4 Reforestation/Buffer Establishment**

Trees provide air and water quality benefits, as well as aesthetic value. They provide habitat for terrestrial and aquatic wildlife and shade that helps keep water temperatures low. Trees also help slow runoff and absorb nutrients through their root systems. Converting open pervious areas into forested areas through tree planting can reduce pollutant loads to nearby water bodies and also reduce erosion. Consideration should also be made to the potential relocation of aerial utility lines to increase tree coverage along street frontage and other areas where shading and infiltration would be beneficial. The City of Columbia manages a tree planting program that has been installing 500-800 trees per year.

Trees improve water quality by capturing and removing pollutants in runoff including excess nutrients through their roots before the pollutants enter groundwater and streams. Tree leaves and stems also intercept precipitation, reducing the energy of raindrops and preventing excess erosion from their impact on the ground. In addition to water quality improvement, trees provide air quality, aesthetic, and economic benefits. For example, trees strategically planted around buildings can form windbreaks to reduce heating costs in the winter and can provide shade, reducing cooling costs in the summer.

Stream riparian buffers are critical to maintaining healthy streams and rivers. Forested buffer areas along streams improve water quality and prevent flooding by filtering pollutants, reducing surface runoff, stabilizing stream banks, trapping sediment, and providing habitat for various types of terrestrial and aquatic life. Buffer encroachment as a result of development was consistently noted during uplands and stream surveys conducted throughout the watershed. Approximately 53,000 linear feet of inadequate buffer was identified during the stream cruising effort. Channel encroachments limit available space for riparian buffer establishment.

#### **7.1.1.5 Infrastructure Improvement**

As discussed in the Hydrology and Hydraulic section (**Section 4.3**) above, replacement of undersized culverts, stabilization of outfalls, and removal of channel obstructions would improve conveyance of storm events and reduce flooding. Building on current analysis and recommendations from previous studies, the proposed improvements focus primarily on new cross section recommendations at crossings that play a large role in controlling water surface profiles.

Numerous storm drain outfalls are located along Smith Branch, and many are in disrepair. Outfall retrofits consist of various methods used to reduce velocity and energy and the potential for scour. Modifications include lowering the outfall to the current stream bed elevation, constructing energy dissipation stilling basins, providing riprap outfall protection, and repairing failed end walls. Repairing outfalls will reduce the sediment load within the channel during rain events by reducing the velocity and energy of these outfalls, thus improving the water quality within Smith Branch.

Exposed utilities along Smith Branch and its tributaries should be addressed. These utilities risk rupture or damage due to debris conveyed by storm events, as well as disrupt flow creating erosion and in stream obstructions. Modifications to either the channel or utility should be evaluated.



### 7.1.2 Enhanced Stormwater Management Requirements

While the Smith Branch Watershed is considered a Vital Water Resource which enacts more stringent stormwater management criteria, additional steps are recommended to improve water quality and reduce peak discharges within the watershed. Since this watershed is comprised of many smaller urban parcels, development activities will often result in less than one acre of disturbance, allowing the development to be exempt from the more restrictive vital water resource criteria. Reducing the one acre minimum disturbance requirement to 0.20 acres would mandate greater implementation of low impact design, while allowing smaller residential redevelopment to occur on individual lots without placing undue financial burden on homeowners. Additional, elimination of the ability to acquire waivers or variances in special protection watersheds would help enforce the current regulations for the area. If for some reason, a development project could not meet the stormwater regulations, a fee in lieu program should be developed. Fees generated by this program would be used to provide regional stormwater retrofit activities such as stream restoration, green streets, or property acquisition within the stream buffer areas. Many urban cities have intensive fee in lieu programs that not only account for an initial fee, but a reoccurring fee placed on the property for utilizing the fee in lieu program.

In addition of enhanced stormwater management regulations, the City should enforce current regulations to the fullest. Section 21-46 of the Columbia, SC Code of Ordinances indicates:

*“Every person owning property through which a watercourse passes, or such person's lessee(s), shall keep and maintain that part of the watercourse within the property free of trash, debris, excessive vegetation (other than that which is required by water quality buffers), and other obstacles that would pollute, contaminate, or significantly retard the flow of water through the watercourse. In addition, the owner(s) or lessee(s) shall maintain existing privately owned structures within or directly adjacent to a watercourse, so that such structures will not become a hazard to the use, function or physical integrity of the watercourse.”*

Smith Branch, for the majority, is encapsulated by privately, university, or state owned land. In many of these instances, the stream has been neglected and not properly maintained as directed in the City Ordinance. Enforcement of this regulation, with proper public education, would have a minimal expense for the City while improving the conveyance within the channel.

Many jurisdictions faced with flooding and water quality issues are turning to volume reduction methodology in lieu of traditional peak management approaches (detention/retention). Volume reduction consists of capturing runoff and infiltrating it onsite while not allowing it to be discharged offsite effectively maintaining the sites predevelopment hydrology such as woods in good condition. An alternative to volume reduction, for areas that lack infiltration due to high ground water or poor soils, treatment of runoff up to 2.6 inches have been implemented. This approach is equivalent to storing and providing water quality treatment of the 1-year storm runoff volume.

### 7.1.3 Stormwater Education and Outreach

Education and outreach tools can be used to inform residents of the water quality impacts associated with large impervious parking lots, driveways, or patios and options available for



conversion to or incorporating more permeable surfaces. We know that Sustainable Midlands, the Smith Branch Watershed Alliance and other watershed groups have very active outreach programs in the Columbia area already. The City has programs such as Blue Thumb Landscaper and My River Starts Here which serve to raise awareness of watershed health and the importance of the individual resident's role in watershed health. Continuing to develop existing and similar programs is recommended.

**Figure 7.1 Example City of Columbia Educational Program: My River Starts Here**



#### **7.1.4 Tree Planting Incentives Programs**

Tree planting incentive programs to convert private open areas in the upland portions of the watershed can help increase the success of planting efforts. Converting open pervious areas into forested areas through tree planting can reduce pollutant loads to nearby water bodies and also reduce erosion. Canvassing residents and/or contacting homeowner associations can be effective techniques for implementing an open space tree planting program within a neighborhood. Initiatives such as the 10,000 Tree Program co-sponsored by the City of Columbia and Columbia Green are recommended.

## **7.2 Citizen-Based Strategies**

The participation of citizens in watershed restoration is an essential part of the integrated watershed plan process. When large numbers of individuals become involved in citizen-based water quality improvement initiatives, changes can be made to the aesthetic and chemical aspects of waterways within a watershed that would not be possible otherwise. Citizen participation and stewardship is critical to the implementation and long-term maintenance of restoration activities. Key citizen-based strategies proposed for Smith Branch are discussed in the following sections.

### **7.2.1 Downspout Disconnection**

Disconnected downspouts that direct rooftop runoff to pervious surfaces can help reduce runoff and pollutants introduced to local streams. This can be achieved through downspout redirection (from impervious to pervious areas, i.e. driveways to lawns), rain barrels, and/or rain gardens. A combination of outreach and awareness techniques and financial incentives can be used to implement a downspout disconnection program in neighborhoods identified as potential candidates.



### **7.2.2 Residential Nutrient Management and Lawn Maintenance**

Raising awareness among citizens about some of the common activities around their homes and how those activities can negatively affect water quality is a vital, citizen-based strategy. Yards and lawns represent a significant portion of the pervious cover in a subwatershed and act as a major source of polluted runoff. Maintenance behaviors tend to be similar within individual neighborhoods and certain activities can impact subwatershed quality such as fertilization, pesticide use, watering, landscaping, and trash/yard waste disposal. Residential nutrient management efforts related to lawn can help reduce polluted runoff to nearby streams.

A well-maintained lawn can be beneficial to the watershed. However, lawn maintenance activities often involve over-fertilization, poor pest-management, and over watering resulting in polluted stormwater runoff to local streams. Lawns with a dense, uniform grass cover or signs designating poisonous lawn care indicate high lawn maintenance activities. Neighborhoods identified as having high lawn maintenance practices should be targeted for awareness programs emphasizing responsible fertilizing techniques such as proper application amount, proper time of year for fertilization, soil testing for nutrient requirements, and keeping fertilizers away from impervious surfaces. Lawn maintenance education can be achieved through door-to-door canvassing, informational brochures/mailings, excerpts in community newsletters, or demonstrations at community meetings. Information on organic alternatives to chemical lawn treatments should also be included in these outreach efforts.

### **7.3 Evaluation of Restoration Opportunities**

Widespread factors such as high percent impervious cover, minimal quantity and quality controls for stormwater, length of enclosed pipe sections and associated erosive outfalls and poor instream and riparian habitat characterize the Smith Branch Watershed as requiring immediate and expansive application of restoration and management activities. Essentially, all strategies for watershed management and project implementation presented herein should be applied watershed wide and in an aggressive manner.

Recommended locations and prioritization for restoration projects was based on a combination of the results of the hydrologic and hydraulic modeling (SWMM) and detailed field reconnaissance and data collection. The SWMM modeling has identified specific subwatersheds and locations within each where stormwater flow is most problematic; where flooding is prevalent from highly impervious areas with no storage or controls. Addressing these problem areas and the contributing drainage is clearly a necessary priority presented herein. Improvement recommendations in these areas could include everything from a major structural fix to widespread implementation of neighborhood BMP's.

Priority projects will also be extracted from the stream cruising data collected from the field reconnaissance and recommended where a) a particular problem is numerous and extensive within a particular area or subwatershed (e.g. the long concrete flume along Bay Branch in SW-D) and b) the severity of a problem identified is so severe to warrant restorative action. It should be noted that although the highly impervious, flood generating areas and their contributing watershed area will be the focus, additional projects will be recommended even though they are not associated directly with a flooding problem.

In addition to flood generating areas, locations with multiple / chronic issues and highly severe sites, prioritization projects also have been selected within public and institutionalized properties.



These include City, County, State and University properties. The large footprint of these properties within the Smith Branch Watershed and the relative ease and feasibility of implementing a restorative project on public versus on private properties raises the priority.



## 8.0 Watershed Project Identification and Prioritization

Through integration of the in-field assessment efforts, SWMM modeling results, and watershed goals established by the stakeholders, 141 Watershed Projects have been identified within the Smith Branch Watershed (**Figure 8.1**). **Table 8.1** (Individual Project Identification and Description) summarizes the results of the subwatershed prioritization and associated project identification. The prioritization ranking for the subwatersheds is directly related to the results of the hydraulic modeling which revealed SW-H and SW-F were most in need of rehabilitation. Within each subwatershed, projects were evaluated on acres of impervious treated, available open space, property ownership, potential conflicts, ease of construction, and cost.

Projects in **Table 8.1** have been grouped into five primary categories: LID or Low Impact Development which includes Green Roofs, Green Streets, and various BMP's to increase infiltration and reduce runoff; Stream Restoration including bank stabilization and day-lighting; Infrastructure Improvements which primarily denotes a recommendation for the replacement of a large drainage structures, modifications to an existing culvert to improve efficiency or relocation or repairs to exposed utilities; Reforestation/Buffer Enhancement such as tree plantings in open spaces and along stream channels; and Stormwater Management which includes both recommendations to retrofit existing systems and proposals for additional detention projects.

Since the Smith Branch Watershed is an urban, heavily developed watershed, it is hard to find singular locations in each subwatershed to install a stormwater facility of a size adequate enough to result in an improvement to the watershed. Because of this a wide reaching network of stormwater facilities and retrofit opportunities are needed. A desktop analysis was performed on each subwatershed to identify areas that appear to have the available open space for a retrofit opportunity. These locations ranged from installing bioretention facilities within parking lots, tree planting in areas of open ROW, to retention or detention ponds. Larger scale projects such as implementation of green streets should be included in future planning studies and large scale capital improvement projects such as major roadway rehabilitation. While these approaches have the ability to treat a large impervious area, because of their associated costs and level of planning involved they have been ranked lower than more affordable individual sites with fewer constraints to schedule and constructability. **Table 8.1** provides descriptions of project type, approximate size, location, proposed action, potential benefits, known constraints and estimated cost.

**Legend**

- Infrastructure Improvements
- Low Impact Development
- ◆ Reforestation/Buffer Establishment
- ▲ Stormwater Management
- ~ Stream Restoration
- ~ Open Stream Channel
- ⬭ Subwatershed

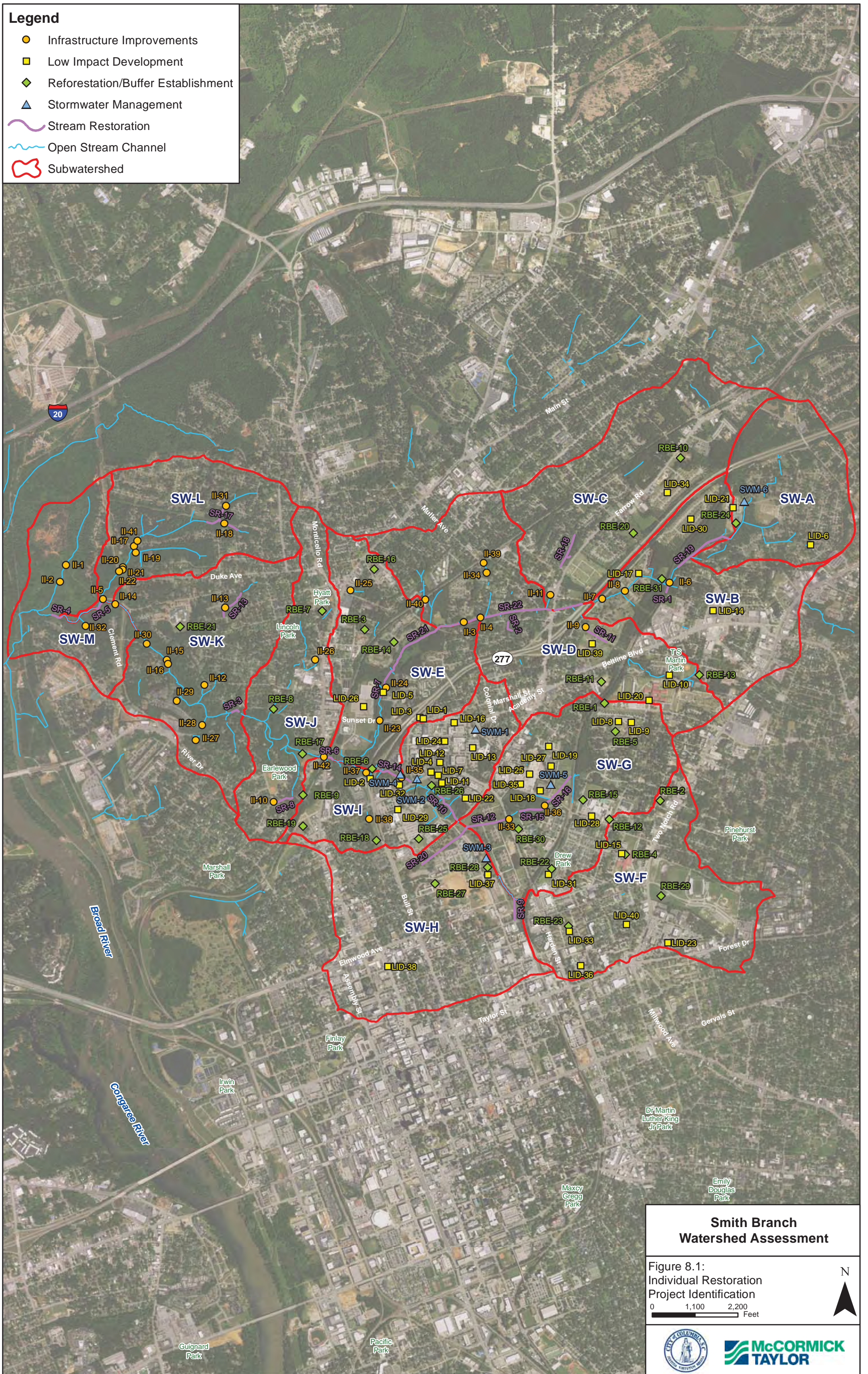




Table 8.1: Individual Project Identification and Description

		Stormwater Management	Infrastructure Improvements	Stream Restoration	LID	Reforestation/Buffer Establishment		
Project ID	Sub-watershed	Project Type	Location	Proposed Action	Benefits	Known Utilities and/or Constraints	Estimated Cost*	Additional Notes
SWM-1	SW-I	Stormwater Management pond	Parking Lot at Grand St and Shealy St	Retrofit existing dry pond to provide water quality or additional storage	Reduce impacts of outfall on Smith Branch and provide opportunities for quantity and water quality treatment		\$150,000	
SWM-2	SW-I	Stormwater Management pond	Parking Garage at Medical Park Rd and Harden St Extension	Construct shallow marsh or wet pond to treat runoff from parking garage and adjacent roads	Reduce impacts of outfall on Smith Branch and provide opportunities for quantity and water quality treatment	utility lines	\$250,000	
SWM-3	SW-H	Stormwater Management pond	Department of Mental Health, Hall Institute	Construct shallow marsh or wet pond to treat runoff from complex	Provide opportunities for quantity and water quality treatment	utility lines	\$350,000	
SWM-4	SW-I	Stormwater Management pond	Outfall from USC Medical Complex on Medical Park Rd	Pull back section of storm drain away from Smith Branch to allow for construction of shallow marsh or wet pond.	Reduce impacts of outfall on Smith Branch and provide opportunities for quantity and water quality treatment	property ownership, utility lines	\$350,000	
SWM-5	SW-G	Stormwater Management pond	West of Howell St, North of Slighs Ave	Construct shallow marsh or wet pond to treat runoff from Howell Street and townhomes	Provide opportunities for quantity and water quality treatment	utility lines	\$350,000	
SWM-6	SW-A	Stormwater management pond	Northeast within Burton-Pack Elementary School	Retention pond to control runoff from SC-277	Provide opportunities for quantity and water quality treatment		\$350,000	Frequently flooded area
II-1	SW-M	Culvert addition	Access Road west of Mountain Dr.	Add culvert through gravel access road	Reducing flooding	property ownership	\$15,000	Gravel road cuts through stream
II-2	SW-M	Culvert addition	Access road west of Mountain Dr.	Add culvert through gravel access road	Reducing flooding		\$15,000	Gravel road cuts through stream
II-3	SW-D	Utility Line Repair	Grand St Bridge	Repair pipe bracketed to bridge	Protect utility line	utility lines	\$25,000	
II-4	SW-D	Utility Line Repair	Colonial Dr Bridge	Repair pipe bracketed to bridge	Protect utility line	utility lines	\$25,000	
II-5	SW-L	Culvert Stabilization	Mountain Dr. crossing	Stabilize downstream side	Stabilize culvert to protect infrastructure and reduce erosion	utility lines	\$40,000	Recent repair, riprap slumping down bank face
II-6	SW-B	Utility Line Repair	Southwest of Elcan St	Repair exposed sanitary line in bed	Protect utility line	utility lines, property ownership	\$45,000	
II-7	SW-B	Utility Line Repair	Between Lester Dr and Colony Forest Dr	Repair exposed sanitary line in bed	Protect utility line	utility lines	\$45,000	
II-8	SW-B	Utility Line Repair	Southeast of Ripplemeyer Ave	Repair exposed sanitary line in bed	Protect utility line	utility lines, property ownership	\$45,000	
II-9	SW-D	Utility Line Repair	West of Bailey St	Repair exposed sanitary line suspended above bed	Protect utility line	utility lines, property ownership, telephone lines	\$50,000	
II-10	SW-J	Outfall Repair	East of Earlewood Drive, North of George St	Repair broken sanitary line, blue/green discharge visible	Reduce erosion and improve water quality	utility lines	\$50,000	
II-11	SW-C	Utility Line Repair	South of Columbia College Dr, West of Farrow Rd	Relocate utility line	Protect utility line	property ownership, utility lines	\$50,000	Crosses culvert opening, likely to trap debris or be damaged
II-12	SW-K	Utility Line Repair	West of Summerlea Dr, Avondale Dr intersection	Repair exposed utility line in bed	Protect utility line	property ownership, utility lines	\$50,000	
II-13	SW-K	Utility Line Repair	Between Hilltop Pl and Jackson Ave cul-de-sacs	Exposed pipe in channel bed	Protect utility line	utility line	\$50,000	
II-14	SW-K	Utility Line Repair	East of Clement Rd, south of Mountain Dr	Exposed pipe in channel;	Protect utility line	property ownership, utility lines	\$50,000	
II-15	SW-K	Utility Line Repair	East of Ardincaple Dr, West of Cumberland Dr	Exposed pipes in channel	Protect utility line	utility line	\$50,000	Consider combining with II-16



Project ID	Sub-watershed	Project Type	Location	Proposed Action	Benefits	Known Utilities and/or Constraints	Estimated Cost*	Additional Notes
II-16	SW-K	Utility Line Repair	East of Ardincaple Dr, West of Cumberland Dr	Exposed pipes in channel	Protect utility line	utility line	\$50,000	Consider combining with II-15
II-17	SW-L	Utility Line Repair	South of Pineneedle Rd, West of Brookridge Dr	Exposed pipe in channel bed	Protect utility line	property ownership, utility lines	\$50,000	
II-18	SW-L	Utility Line Repair	South of Steadham Rd	Exposed pipe in channel bed	Protect utility line	property ownership, utility lines	\$50,000	
II-19	SW-L	Utility Line Repair	South of Pineneedle Rd, West of Brookridge Dr	Exposed pipe in channel bed	Protect utility line	property ownership, utility lines	\$50,000	
II-20	SW-L	Utility Line Repair	ROW west of Courtridge St	Exposed pipe in channel bed	Protect utility line	property ownership, utility lines	\$50,000	eastern utility of 3 exposed within ROW
II-21	SW-L	Utility Line Repair	ROW west of Courtridge St	Exposed pipe in channel bed	Protect utility line	property ownership, utility lines	\$50,000	central utility of 3 exposed within ROW
II-22	SW-L	Utility Line Repair	ROW west of Courtridge St	Exposed pipe in channel bed	Protect utility line	property ownership, utility lines	\$50,000	western utility of 3 exposed within ROW
II-23	SW-E	Utility Line Repair	Sunset Dr. Crossing	Move exposed sanitary line away from culvert opening	Protect utility line	utility lines	\$75,000	Potential for trapping debris in culvert
II-24	SW-E	Outfall stabilization	West of Medical Dr.	Repair outfall	Stabilize outfall to protect infrastructure and reduce erosion	property ownership	\$75,000	Terminal segments disjointed
II-25	SW-E	Outfall stabilization	East of North Main St, North of Johnson Ave	Repair outfall	Stabilize outfall to protect infrastructure and reduce erosion	property ownership, utility lines	\$75,000	Scoured under grouted pad, excessive litter and some tires
II-26	SW-J	Outfall stabilization	South of Miller Ave, West of North Main St	Repair outfall	Stabilize outfall to protect infrastructure and reduce erosion	utility lines	\$75,000	Outfall undercut
II-27	SW-K	Outfall Stabilization	North of Makeway Dr, South of Sunset Dr	Repair head cut downstream of outfall	Stabilize outfall to protect infrastructure and reduce erosion	property ownership, utility lines	\$75,000	Head cut approaching house foundation
II-28	SW-K	Outfall Stabilization	West of Falling Springs Rd, North of Sunset Dr	Repair head cut downstream of outfall, remove rubble	Stabilize outfall to protect infrastructure and reduce erosion	property ownership, utility lines	\$75,000	
II-29	SW-K	Outfall Stabilization	East of Ardincaple Dr, North of Falling Springs Rd	Repair head cut downstream of outfall, remove rubble	Stabilize outfall to protect infrastructure and reduce erosion	utility lines	\$75,000	
II-30	SW-K	Utility Line Repair	East of Ardincaple Dr., near Ayshire Ave	Exposed pipe in channel	Protect utility line	property ownership, utility lines	\$75,000	Pipe is cracked and spraying into stream, also creating fish blockage
II-31	SW-L	Culvert Stabilization	North of Wildsmere Ave, East of Hawthorne Ave	Repair upstream side of culvert	Stabilize culvert to protect infrastructure and reduce erosion	property ownership	\$75,000	Pipe section disconnected, scour around upstream face
II-32	SW-M	Outfall Stabilization	Between Clement Rd and Williamsburg Dr	Stabilize downstream side of outfall	Stabilize outfall to protect infrastructure and reduce erosion	property ownership, pond dam	\$75,000	Scour around outfall endangering dam
II-33	SW-G	Outfall Repair	CM Tucker Nursing Care Center	Repair damaged outfall, investigate poor water quality of discharge	Stabilize outfall to protect infrastructure, improve water quality and reduce erosion		\$100,000	
II-34	SW-D	Outfall repair	East of Colonial Dr, North of Cromer Ave	Stabilize outfall	Stabilize outfall to protect infrastructure and reduce erosion	property ownership	\$100,000	Channel is headcutting
II-35	SW-I	Outfall retrofit	Outfall from USC Medical Complex on Medical Park Rd	Pull back section of outfall away from Smith Branch to allow for treatment of storm drain flow.	Reduce impacts of outfall on Smith Branch and provide opportunities for infiltration and water quality treatment	property ownership, utility lines	\$125,000	On USC property and should be included with LID-32 and SR-14
II-36	SW-G	Outfall Repair	CM Tucker Nursing Care Center	Repair damaged outfall	Stabilize outfall to protect infrastructure and reduce erosion	utility lines	\$125,000	Headwall undercut and cracking



Project ID	Sub-watershed	Project Type	Location	Proposed Action	Benefits	Known Utilities and/or Constraints	Estimated Cost*	Additional Notes
II-37	SW-I	Outfall Stabilization	West of Smith Branch mainstem culvert under SC-277	Headwall undercut and cracking, replacement. Head cut downstream	Stabilize outfall to protect infrastructure and reduce erosion	property ownership	\$150,000	
II-38	SW-I	Outfall Stabilization	North of Geiger Ave.	Repair outfall, undercut apron, and head cut downstream	Stabilize outfall to protect infrastructure and reduce erosion		\$150,000	
II-39	SW-D	Utility Line Repair and Outfall Replacement	South of Seaboard Ave, East of Colonial Dr	Repair damaged outfalls and exposed water line	Stabilize outfall to protect infrastructure and reduce erosion	utility lines, property ownership	\$150,000	
II-40	SW-D	Culvert Replacement	Railroad crossing North of Lorick Park	Repair railroad crossing.	Reducing flooding	railroad, utility lines, property ownership	\$150,000	
II-41	SW-L	Culvert Replacement	Brookridge Dr Crossing	Replace culvert	Reducing flooding	property ownership, utility lines	\$250,000	Upstream side mostly buried, active flooding area
II-42	SW-I	Culvert Replacement	Main St Bridge over Smith Branch mainstem	Replace with dual 12' x 12' culverts	Reduce flooding	utility lines	\$1,500,000	
SR-1	SW-B	Bank Stabilization	West of Hammond Ave and South of Elcan st	Repair head cut (~120LF)	Reduce stream bank erosion and protect infrastructure	property ownership and railroad	\$50,000	Could potentially impact railroad embankment
SR-2	SW-D	Bank Stabilization	South of Chappelle St	Stabilize ~200LF	Reduce stream bank erosion and protect infrastructure and private property	property ownership	\$80,000	
SR-3	SW-K	Bank Stabilization	West of Sunset Dr	Stabilize right bank of Smith Branch Mainstem downstream of culvert ~200LF	Reduce erosion and improve water quality	property ownership	\$80,000	
SR-4	SW-M	Bank Stabilization	North of Williamsburg Dr.	Bank Stabilization ~250LF	Reduce stream bank erosion and protect infrastructure	property ownership, utility lines	\$100,000	Tall bank composed of fill material
SR-5	SW-M	Bank Stabilization	South of Mountain Dr.	Smith Branch Mainstem Bank Stabilization (~300LF) downstream of Clement Rd crossing	Reduce stream bank erosion and protect infrastructure	property ownership	\$120,000	Stream migration around debris jam
SR-6	SW-I	Bank Stabilization	Smith Branch Mainstem east of Main St (upstream of culvert)	Bank stabilization ~ 400 LF	Reduce stream bank erosion and protect infrastructure	property ownership, utility lines	\$160,000	Expansion into utility ROW
SR-7	SW-E	Bank Stabilization	West of Medical Dr.	Bank Stabilization ~ 400 LF	Reduce stream bank erosion and protect infrastructure	property ownership, utility lines	\$160,000	Consider combining with II-24 and LID-5
SR-8	SW-J	Bank Stabilization	Earlewood Park at Earlewood Dr	Stabilize banks of gully in upper reaches of park (~ 450 LF)	Reduce erosion and improve water quality	utility lines	\$180,000	
SR-9	SW-H	Stream Restoration	Pipe segment north of Calhoun St by Railroad that drains to Bull St Redevelopment	54 inch pipe daylight ~ 500 LF into Smith Branch Mainstem	Opportunity to remove stream from closed system, reduce flooding	utility lines	\$200,000	Located in upper portion of redevelopment
SR-10	SW-I	Bank Stabilization	Extends west from Colonial Dr towards Harden St. Extension	Remove beaver dam and stabilize headcuts and bank erosion. Floodplain reconnection ~ 600 LF	Reduce stream bank erosion and floodplain reconnection	utility lines	\$240,000	
SR-11	SW-D	Bank Stabilization	Southeast of Lester Dr.	Stabilize banks and restore stream ~600 LF	Reduce stream bank erosion, improve vegetated cover and protect infrastructure	utility lines, property ownership, telephone lines	\$240,000	Consider combining with II-9
SR-12	SW-G	Stream Restoration	West of Harden St -South of Colonial Dr -On Bull St Redevelopment Site	Daylight piped channel on Bull Street Development Site ~ 800 LF	Opportunity to remove stream from closed system, improve infiltration and water quality	utility lines	\$320,000	This could also take the form of stormwater management via a pond system
SR-13	SW-K	Bank Stabilization	West of Abingdon Rd	Bank Stabilization ~800 LF	Reduce stream bank erosion and protect infrastructure	utility lines	\$320,000	
SR-14	SW-I	Stream Restoration	Smith Branch Mainstem just east of SC-277 and north of Harden St Extension	Reshape and stabilize channel reach ~ 900 LF	Reduce stream bank erosion and protect infrastructure	property ownership, utility lines	\$360,000	On USC property. Extends into SW-E. Consider combining with II-35



Project ID	Sub-watershed	Project Type	Location	Proposed Action	Benefits	Known Utilities and/or Constraints	Estimated Cost*	Additional Notes
SR-15	SW-G	Stream Restoration	Mental Health Development Property	Restore stream between Slighs and Eagle Ave ~900 LF	Restore incised stream to dissipate energy and reduce erosion	utility lines	\$365,000	Consider combining with II-36
SR-16	SW-G	Stream Restoration	James Clyburn Golf Center	Daylight stream section between RR and Slighs Ave ~1,000 LF	Opportunity to remove stream from closed system, improve infiltration and water quality	utility lines	\$400,000	
SR-17	SW-L	Bank Stabilization	South of Wildsmere Ave	Bank Stabilization ~1200 LF	Reduce stream bank erosion	property ownership, utility lines	\$480,000	
SR-18	SW-C	Bank Stabilization	East of Jones St	Stabilize banks, remove concrete/masonry lined channel	Improve infiltration and habitat, reduce stream bank erosion, and protect infrastructure	property ownership	\$480,000	
SR-19	SW-B	Bank Stabilization	West of northern end of Hammond Ave	Bank stabilization ~1,400 LF	Reduce stream bank erosion and protect infrastructure	property ownership, telephone poles	\$560,000	
SR-20	SW-H	Stream Restoration	South of Colonial Dr	Daylight stream section within the SC Department of Mental Health ~2000 LF	Opportunity to remove stream from closed system, improve infiltration and water quality	utility lines	\$800,000	
SR-21	SW-E	Stream Restoration	East of Lorick Circle - Bay Branch Mainstem downstream of Lorick Ave	Stabilize banks, floodplain reconnection, bmps (~2000 LF)	Reduce stream bank erosion, floodplain reconnection and protect infrastructure	utility lines	\$800,000	
SR-22	SW-D	Stream Restoration	Bay Branch Mainstem within SW-D	Remove concrete channel ~3,000 LF	Improve infiltration and habitat	property ownership, utility lines	\$1,200,000	
LID-1	SW-I	BMP install	Ramp from Medical Park Rd to WB SC277	Construct bioretention	Reduce flow velocities to receiving waters and provide infiltration or water quality treatment		\$50,000	Work also in SW-E
LID-2	SW-I	BMP install	Median of SC-277 north of Harden St Extension	Replace concrete flume with rock dissipation/step structure	Reduce flow velocities to receiving waters and provide infiltration	utility lines	\$75,000	Work also in SW-E
LID-3	SW-I	BMP install	Ramp from Medical Park Road to WB SC-277	Replace concrete flume with bioswale or bioretention	Reduce flow velocities to receiving waters and provide infiltration or water quality treatment		\$75,000	Work also in SW-E
LID-4	SW-I	BMP install	Entrance to Palmetto Health at Harden St Extension	Construct bioretention	Reduce flow velocities to receiving waters and provide infiltration or water quality treatment	utility lines	\$75,000	
LID-5	SW-E	BMP install	Alston Wilkes Society -Veterans Care facility	Parking lot abuts stream - section needs to be removed and additional BMP's installed	Remove structure from stream cross proper to reduce erosion and flooding	telephone lines	\$75,000	
LID-6	SW-A	BMP install	West of Kaiser Ave, North of Belvedere Dr	Replace concrete flume with rock dissipation/step structure	Reduce flow velocities to receiving waters, reducing erosion	property ownership/perhaps an easement	\$75,000	Inlet at bottom of structure likely to be replaced as well
LID-7	SW-I	BMP install	Harden St Extension from Colonial Dr to Palmetto Health	Construct bioretention or bioswale	Reduce flow velocities to receiving waters and provide infiltration or water quality treatment	utility lines	\$150,000	
LID-8	SW-G	BMP install	Watkins-Nance Elementary School	BMP's for parking - Bioretention in open areas	Provide enhanced treatment of parking lot runoff for water quality improvement	utility lines	\$150,000	
LID-9	SW-G	BMP install	Nance School - Grant St	Downspout disconnection, bioretention for parking	Provide enhanced treatment of parking lot and roof runoff for water quality improvement	utility lines	\$150,000	
LID-10	SW-D	BMP install	TS Martin Park	Install bioretention areas between park parking lot and ball fields	Provide enhanced treatment of parking lot and ballfield runoff for water quality improvement.	utility lines	\$150,000	
LID-11	SW-I	BMP install	SC Dept of Disabilities and Special Needs Complex on Harden St Extension	Construct Bioretention BMPS within parking lot or at existing outfalls	Provide enhanced treatment of parking lot runoff for water quality improvement.		\$300,000	
LID-12	SW-I	BMP install	Palmetto Health Parking Lot	Construct bioretention cells within parking islands	Reduce flow velocities to receiving waters and provide infiltration or water quality treatment		\$300,000	



Project ID	Sub-watershed	Project Type	Location	Proposed Action	Benefits	Known Utilities and/or Constraints	Estimated Cost*	Additional Notes
LID-13	SW-I	BMP install	Palmetto Health Parking Lot	Construct bioretention cells within parking islands	Reduce flow velocities to receiving waters and provide infiltration or water quality treatment		\$300,000	
LID-14	SW-B	BMP install	Behind Piggly Wiggly on W. Beltline Blvd	Bioretention BMP's for parking lot	Provide enhanced treatment of parking lot runoff for water quality improvement		\$300,000	Area appears to now be publicly owned.
LID-15	SW-F	BMP install	Carver-Lyon Elementary School	Bioretention BMP's for parking lot. Open space available for detention.	Provide enhanced treatment of parking lot runoff for water quality improvement	utility lines	\$350,000	
LID-16	SW-I	BMP install	801 Sunset Clinics	BMP's for parking lots	Provide enhanced treatment of parking lot runoff for water quality improvement.	property ownership, utility lines	\$350,000	Large area of application potential here.
LID-17	SW-B	Green Streets	Ripplemeyer Ave, Colony Forest Dr	Green Streets	Provide enhanced treatment of parking lot and ballfield runoff for water quality improvement.	property ownership, utility lines	\$350,000	
LID-18	SW-G	BMP install	Howell Court	Install bioretention areas between park parking lots and Howell Court	Provide enhanced treatment of parking lot and road runoff for water quality improvement.	property ownership, utility lines	\$350,000	
LID-19	SW-G	BMP install	Palmetto Terrace Apartments	Install bioretention areas between park parking lots and Howell Street	Provide enhanced treatment of parking lot and road runoff for water quality improvement.	property ownership, utility lines	\$350,000	
LID-20	SW-D	BMP install	W.A. Perry Middle School	Downspout disconnection, bioretention for parking	Provide enhanced treatment of parking lot and roof runoff for water quality improvement		\$350,000	
LID-21	SW-A	BMP install	Burton-Pack Elementary School and recreational area	Downspout disconnection, bioretention for parking	Provide enhanced treatment of parking lot and roof runoff for water quality improvement		\$350,000	
LID-22	SW-I	BMP install	SC Child Support Enforcement Building - Harden St Extension and Colonial Dr	BMP's for parking lot	Provide enhanced treatment of parking lot runoff for water quality improvement.		\$380,000	
LID-23	SW-F	BMP install	Providence Hospital Complex	Bioretention BMP's for parking lot	Provide enhanced treatment of parking lot runoff for water quality improvement	property ownership	\$400,000	average per parking lot
LID-24	SW-I	BMP install	Richland Memorial Hospital Complex	BMP's for parking lots	Provide enhanced treatment of parking lot runoff for water quality improvement.	utility lines	\$400,000	average per lot, Large area of application potential here.
LID-25	SW-G	BMP install	City of Columbia Fleet Services - Slighs Ave	BMP's for parking lot	Provide enhanced treatment of parking lot runoff for water quality improvement.		\$400,000	
LID-26	SW-E	BMP install	Abandoned warehouse parking lot north of SC 16 and west of SC-277	BMP's on large uncontrolled parking lot	Provide enhanced treatment of parking lot runoff for water quality improvement.	property ownership, utility lines	\$400,000	
LID-27	SW-G	BMP install	Palmetto Terrace Apartments	Install bioretention areas between park parking lots and Howell Street	Provide enhanced treatment of parking lot and road runoff for water quality improvement.	property ownership, utility lines	\$450,000	
LID-28	SW-G	BMP install	C.A. Johnson High School	BMP's for parking lot and tennis courts	Provide enhanced treatment of parking lot runoff for water quality improvement.	utility lines	\$450,000	
LID-29	SW-I	BMP install	SC DHEC building -Bull and Harden Street Extension	BMP's for parking lot	Provide enhanced treatment of parking lot runoff for water quality improvement.		\$500,000	
LID-30	SW-B	Green Streets	Bayberry Mews Apartments - Lester Drive, Bay Shell Drive, Ginger Root Way	Green Streets	Provide enhanced treatment of parking lot and ballfield runoff for water quality improvement.	property ownership, utility lines	\$500,000	
LID-31	SW-G	BMP install	Drew Park	Create detention BMP feature within oval walkway grassed area	Opportunity to remove storm drain pipes and provide detention for water quality improvement		\$500,000	
LID-32	SW-I	BMP install	Between Harden St Extension, Medical Park Rd and SC-277	Restripe main parking lots for the medical park buildings; remove small detached lot closest to Harden St Extension and provide BMP's for all lots draining into Smith Branch	Reduce impervious cover and provide BMP's to allow for infiltration and water quality improvement	property ownership, utility lines	\$550,000	USC property. Work also in SW-E



Project ID	Sub-watershed	Project Type	Location	Proposed Action	Benefits	Known Utilities and/or Constraints	Estimated Cost*	Additional Notes
LID-33	SW-F	Green Streets	Allen Benedict Court	Green Streets- Bioretention bump outs	Provide enhanced treatment of parking lot and roadway runoff for water quality improvement	utility lines	\$570,000	
LID-34	SW-C	Green Streets/ BMP install	Bayberry Mews Apartments - Cardamon Ct, Tarragon Way, Ginger Root Way	Green Streets	Provide enhanced treatment of parking lot and ballfield runoff for water quality improvement.	property ownership, utility lines	\$570,000	
LID-35	SW-G	Green Roof	City of Columbia Fleet Services - Slighs Ave	Install green roof units	Reduce runoff from rooftops		\$600,000	assumes 30,000 SF green roof install
LID-36	SW-F	Green Streets/ BMP install	Benedict College	Green Streets and Parking Lot BMPs	Provide enhanced treatment of parking lot and roadway runoff for water quality improvement	property ownership, utility lines	\$700,000	
LID-37	SW-H	Green Streets/ BMP install	Department of Mental Health, Hall Institute	Green Streets, BMP's for parking lot	Provide enhanced treatment of parking lot runoff for water quality improvement.	utility lines	\$1,200,000	
LID-38	SW-H	Green Streets	Sumter and Marion Streets	Green Streets- Bioretention bump outs	Provide enhanced treatment of parking lot and roadway runoff for water quality improvement	utility lines	\$1,400,000	
LID-39	SW-D	Green Streets/ BMP install	Colony Apartments - Bailey St and Colony Forest Dr	Green Streets, BMP's for parking lot	Provide enhanced treatment of parking lot runoff for water quality improvement.	utility lines, private property	\$1,900,000	
LID-40	SW-F	Green Streets	Development East of Benedict College	Green Streets- Bioretention bump outs	Provide enhanced treatment of parking lot and roadway runoff for water quality improvement	utility lines	\$2,280,000	
RBE-1	SW-G	Tree Planting	W.A. Perry Middle School - Southwest corner of property	Plant trees where feasible	Improve water retention and aesthetics.		\$10,000	\$20,000 per acre. May be more opportunity (area) within school campus.
RBE-2	SW-F	Tree Planting	East of Gordon St and Waites Rd intersection	Plant trees where feasible	Improve water retention and aesthetics.		\$15,000	\$20,000 per acre
RBE-3	SW-E	Tree Planting	Empty lot off Glendon Rd, South of Hendrix St	Plant trees where feasible	Improve water retention and aesthetics.		\$15,000	\$20,000 per acre
RBE-4	SW-F	Tree Planting	Carver-Lyon Elementary School	Plant trees where feasible	Improve water retention and aesthetics.		\$20,000	\$20,000 per acre
RBE-5	SW-G	Tree Planting	Watkins-Nance Elementary School	Plant trees where feasible	Improve water retention and aesthetics.		\$20,000	\$20,000 per acre
RBE-6	SW-E	Tree Planting	SC-277 median	Plant trees where feasible	Improve water retention and aesthetics.		\$20,000	\$20,000 per acre
RBE-7	SW-J	Tree Planting	Hyatt Park	Plant trees where feasible	Improve water retention and aesthetics.		\$20,000	\$20,000 per acre
RBE-8	SW-J	Tree Planting	Northeast of intersection of Sunset Dr. and Margrave Rd	Plant trees where feasible	Improve water retention and aesthetics.		\$20,000	\$20,000 per acre
RBE-9	SW-J	Tree Planting	Earlewood Park	Plant trees where feasible	Improve water retention and aesthetics.		\$20,000	\$20,000 per acre
RBE-10	SW-C	Tree Planting	Northeast of Farrow Rd and Tarragon Dr.	Plant trees where feasible	Improve water retention and aesthetics.		\$20,000	\$20,000 per acre
RBE-11	SW-D	Tree Planting	Southeast of the intersection at Grant St and Carver St	Plant trees where feasible	Improve water retention and aesthetics.		\$24,000	\$20,000 per acre
RBE-12	SW-G	Tree Planting	CA Johnson High School	Plant trees where feasible	Improve water retention and aesthetics.		\$25,000	\$20,000 per acre
RBE-13	SW-D	Tree Planting	TS Martin Park	Plant trees where feasible	Improve water retention and aesthetics.		\$25,000	\$20,000 per acre
RBE-14	SW-E	Tree Planting	Latimer Manor	Plant trees where feasible	Improve water retention and aesthetics.		\$25,000	\$20,000 per acre
RBE-15	SW-G	Tree Planting	CA Johnson High School	Plant trees where feasible	Improve water retention and aesthetics.		\$30,000	\$20,000 per acre
RBE-16	SW-E	Tree Planting	Hyatt Park Elementary School	Plant trees where feasible	Improve water retention and aesthetics.		\$30,000	\$20,000 per acre
RBE-17	SW-J	Buffer Planting	Earlewood Park	Plant buffer on north side of Smith Branch near park entrance	Improve riparian stability and habitat		\$35,000	\$20,000 per acre



Project ID	Sub-watershed	Project Type	Location	Proposed Action	Benefits	Known Utilities and/or Constraints	Estimated Cost*	Additional Notes
RBE-18	SW-I	Tree Planting	West of Bull St, North of Confederate Ave.	Plant trees where feasible	Improve water retention and aesthetics.		\$37,000	\$20,000 per acre
RBE-19	SW-I	Tree Planting	South of Dayton St and Newman St	Plant trees where feasible	Improve water retention and aesthetics.		\$40,000	\$20,000 per acre
RBE-20	SW-C	Tree Planting	Busby St	Plant trees where feasible	Improve water retention and aesthetics.		\$40,000	\$20,000 per acre
RBE-21	SW-K	Tree Planting	Gibbes Middle School	Plant trees where feasible	Improve water retention and aesthetics.		\$40,000	\$20,000 per acre
RBE-22	SW-G	Tree Planting	Drew Park	Plant trees where feasible	Improve water retention and aesthetics.		\$45,000	\$20,000 per acre
RBE-23	SW-F	Tree Planting	Allen Benedict Court Complex	Plant trees where feasible	Improve water retention and aesthetics.		\$60,000	\$20,000 per acre
RBE-24	SW-A	Tree Planting	Burton-Pack Elementary School and recreational area	Plant trees where feasible	Improve water retention and aesthetics.		\$60,000	\$20,000 per acre
RBE-25	SW-I	Tree Planting	SC DHEC	Plant trees where feasible	Improve water retention and aesthetics.		\$70,000	\$20,000 per acre
RBE-26	SW-I	Tree Planting	SC Department of Disabilities and Special Needs	Plant trees where feasible	Improve water retention and aesthetics.		\$75,000	\$20,000 per acre
RBE-27	SW-H	Tree Planting	SC Department of Mental Health	Plant trees where feasible	Improve water retention and aesthetics.		\$80,000	\$20,000 per acre
RBE-28	SW-H	Tree Planting	Department of Mental Health, Hall Institute	Plant trees where feasible	Improve water retention and aesthetics.		\$80,000	\$20,000 per acre
RBE-29	SW-F	Tree Planting	Benedict College Athletic Facility	Plant trees where feasible	Improve water retention and aesthetics.		\$140,000	\$20,000 per acre
RBE-30	SW-G	Tree Planting	CM Tucker Nursing Care Center	Plant trees where feasible	Improve water retention and aesthetics.		\$140,000	\$20,000 per acre
RBE-31	SW-B	Tree Planting	Park South of Bayberry Mews Apartments	Plant trees where feasible	Improve water retention and aesthetics.		\$190,500	\$20,000 per acre

1. LID Estimated Costs assume maximized retrofit footprint. Opportunities exist to reduce scale to reduce cost and/or phase larger projects to budget costs incrementally.



To track progress in implementing stormwater restoration opportunities, the required water quality volume was determined for each subwatershed (**Table 8.2**). This volume was based upon the drainage area and the percent impervious cover. As facilities are constructed, the storage volume provided can be tallied and compared to the required volume that would treat the 1.0 inch or 1.2 inch runoff. As mentioned above, implementation of enough facilities to meet these goals is not practical due to right of way limitations. However, facilities that are feasible to construct can be oversized to provide additional storage towards the goal volume. Filtration facilities such as bioretention can have expanded temporary ponding areas or groundwater recharge reservoirs to store additional runoff. Wherever practical, runoff reduction methods should be utilized to not only provide water quality treatment but quantity management as well through infiltration. For non-structural practices such as pavement removal or tree planting and reforestation; credit can be calculated based upon the acreage of pavement removed. For tree planting, typically a composite of 100 trees per acre is needed to obtain stormwater credit. Because contiguous parcels of one acre or greater are difficult to locate in urban areas, an aggregate of smaller sites may be used. In regards to stream restoration, typically credit may be claimed for 1 acre of treated impervious for every 100 linear foot of restoration. Following this methodology will allow for milestones to be set and progress tracked.

**Table 8.2 Subwatershed Water Quality Volume**

Sub-watershed	Acres	Impervious Cover	Impervious Cover	Rv	Volume Required to Treat the 1" Runoff	Volume Required to Treat the 1.2" Runoff*
		%	Acres		ac-ft	ac-ft
SW-H	464	59%	274	0.58	22.5	27.0
SW-F	400	54%	216	0.54	17.9	21.4
SW-I	309	47%	145	0.47	12.2	14.6
SW-B	369	47%	173	0.47	14.5	17.5
SW-G	404	40%	162	0.41	13.8	16.6
SW-D	506	37%	187	0.38	16.1	19.4
SW-E	342	40%	137	0.41	11.7	14.0
SW-J	285	33%	94	0.35	8.2	9.9
SW-C	463	31%	144	0.33	12.7	15.2
SW-A	273	26%	71	0.28	6.5	7.8
SW-K	409	20%	82	0.23	7.8	9.4
SW-L	299	16%	48	0.19	4.8	5.8
SW-M	230	7%	16	0.11	2.2	2.6
Total	4,753		1,748		150.9	181.1

\*Current "Vital Area" Regulation for New Development within Smith Branch



Within the Smith Branch Watershed there are several areas of low income housing consisting of barren landscapes and very little aesthetics. In addition to improvements to water quality, these retrofit opportunities would help revitalize these areas and provide increased quality of life. Because of these circumstances, federal grants may be available to implement these watershed opportunities.

It should be highlighted that subwatershed ranking correlates to the degree of imperviousness and the modeled and observed impairment. At nearly 40% impervious within the Smith Branch Watershed, the Impervious Cover Model (Schueler, 2005) predicts stream quality that is non-supporting in many areas. As such, much of the focus for watershed improvements in those subwatersheds is recommended in upland and upper watershed areas targeting detention and infiltration to combat the level of imperviousness. That said, even within the highly impervious, non-supporting subwatersheds like SW-H, opportunities exist to restore streams. Stream restoration projects include bank stabilization, restoration of full reaches and the restoration or “daylighting” of channels that are currently in storm drain pipes under the ground. These daylighting projects provide a tremendous opportunity to both improve flooding and water quality conditions to downstream resources, but also as a new amenity that can now be enjoyed by the general public. As presented, there are multiple opportunities to bring back a stream channel that has been underground for 50 years or more. Once the foundation of education and awareness of the local environment is established, it is much easier to identify, fund and implement needed restoration projects.

Proposed restoration treatments were selected based on the goals of the projects, constraints, feasibility and results of detailed site assessments. **Appendix D** provides a selection of available details for the primary restoration categories. In addition, potential design solutions in select areas were developed and illustrated with typical sections and details as appropriate.

While subwatersheds are ranked in priority order based on the degree of imperviousness, prioritization of projects is based on the category/type of project (see **Table 8.1**). To the extent that the City is capable, the City will generally consider the listed projects in presented order. However, it should be noted that many of the projects are on properties other than those owned and/or operated by the City. Due to this factor, as well as others (i.e. accessibility, feasibility, design constraints, etc.), the City may consider projects for implementation in an order other than that presented in **Table 8.1**.



## 9.0 Conclusions and Limitations

The Smith Branch Watershed Assessment Report provides a detailed assessment of the existing conditions of the waterways and contributing watershed, hydrology and hydraulics analysis and recommends strategies and specific projects to reduce flooding and improve water quality. All streams within the watershed were cruised by foot and characterized for existing conditions of instream and riparian habitat, channel stability, presence and condition of drainage infrastructure, utilities and notation of unusual conditions. All data including site photographs are currently available via web link at <http://arcg.is/1T3it7M>. In addition to its utility herein for evaluating the watershed needs and identifying projects, the stream cruising data will be a valuable inventory tool for the City of Columbia. The results of the stream cruising effort revealed nearly 16,000 linear feet of structurally altered channel, 53,000 linear feet of inadequate forest buffer and 28,000 linear feet of erosion.

The results of the hydrology and hydraulics analysis revealed high volumes of runoff from subwatersheds in the upper watershed areas near urbanized centers of the City and County. Of the 13 subwatersheds delineated, nearly half of those have impervious surfaces of 40% and above with the maximum of 59% occurring in SW-H; where the Bull Street Redevelopment Project is under construction. Pinch points on the mainstem at Main Street and Sunset Drive have been identified for potential upgrades to structures. In the upper watershed, highly impervious areas, recommendations to improve flooding conditions include no additions of imperviousness without full accommodations for retention, and the addition of areas throughout the watershed for detention, retention and infiltration.

This Watershed Report provides a basic framework in three main areas to initiate the restoration of the Smith Branch Watershed: Municipal and Institutional Strategies; Citizen Based Strategies; and the implementation of specific Watershed Projects identified. Municipal and Institutional Strategies include effective management and enhancement of Stormwater Regulations and retrofits of existing systems. Citizen based strategies include tree planting and down spout disconnection programs from Outreach Based initiatives. Locally, the Smith Branch Watershed Alliance group is very active and effective with public outreach.

The identification of Watershed Projects (**Table 8.1**) was developed based on the combined results of the stream cruising effort, the hydrology and hydraulics analysis and desktop analysis. The thirteen subwatersheds were scored based on imperviousness, peak discharge and runoff per unit area. A total of 141 Watershed Projects were identified in the Smith Branch Watershed and recommendations for implementation are focused in the areas of need. Projects identified are grouped into five primary categories:

- Stormwater Management which includes both recommendations to retrofit existing systems and proposal for additional detention projects.
- Infrastructure Improvements which primarily denotes a recommendation for the replacement or modification of a large drainage structures but also includes repair of outfalls and exposed utilities
- Stream Restoration including bank stabilization and daylighting;
- LID or Low Impact Development which includes Green Roofs, Green Streets, and various BMP's to increase infiltration and detention;



- Reforestation/Riparian Buffer Enhancement such as tree plantings in open spaces and along stream corridors

Descriptions of project type, approximate size, location, proposed action, potential benefits, known constraints and estimated cost are provided in **Table 8.1**.

Property ownership and constructability (e.g. access, proximity to utilities, etc.), were considered in project selection and prioritization. Although Smith Branch Watershed is highly impacted with many needs for restoration, there are many opportunities available based on the prevalence of public and institutional properties.

Large Infrastructure Improvement projects that are recommended include the replacement of a number of the undersized culverts in areas know to experience frequent flooding.

Stormwater Management facility recommendations in the Smith Branch Watershed include primarily the construction of new ponds or shallow marshes to treat runoff from industrial or institutional complexes. These include shallow marshes at the USC Medical Complex on Medical Park Road and associated parking garage near the Harden Street Extension. The retrofit of existing ponds is recommended either through additional grading for storage and/or reconfiguration of drainage structures to increase retention times. The retrofit of a dry pond is proposed in Colonial Heights area at a parking lot near Grant and Shealy Streets. Recommendations for stormwater management also include a retention pond within Burton Pack Elementary School to manage runoff from SC -277.

Low Impact Development (LID) projects are of particular importance for the Smith Branch Watershed as opportunities to retrofit highly impervious areas with BMP's to induce water detention filtration, and infiltration. Strong candidates for LID implementation include the Green Streets recommendations at Allen Benedict Court, Benedict College and Cotton Town Sumter and Marion Streets. Numerous BMP's for parking lots have also been recommended and include simple re-striping of lots at Medical Park Road near Harden Street. The re-striping will consolidate parking at the primary lots and allow for the removal of a satellite lot that within the riparian area of Smith Branch proper.

Undeveloped or open public areas were identified and listed as having reforestation potential. These typically occur at Parks and Schools such Benedict College, Carver Lyon Elementary and T.S. Martin Park.

Stream restoration projects have also been identified and recommended. Projects include bank stabilization, restoration of full reaches and the restoration or "daylighting" of channels that are currently in storm drain pipes under the ground. These daylighting projects provide a tremendous opportunity to both improve flooding and water quality conditions to downstream resources, but also as a new amenity that can now be enjoyed by the general public. The most significant opportunities for this are available on the Bull Street Development project. The current Master Plan already has incorporated the daylighting of the primary trunk drainage pipe and proposed a combination pond and stream within an open green space. Three additional potential daylighting opportunities within the development have been identified here as Sites SR-9, SR-12 and SR-20. Another significant stream restoration opportunity is the removal and restoration of the concrete flume along Bay Branch starting at Shaw Street in SW-D. The hydrology and hydraulics analysis recommended this option as a means to disconnect flood peaks. Stream restoration projects are also an excellent means to educate and develop public



awareness. There are many opportunities to connect the public and commerce with Smith Branch through these daylighting projects and the continued development of Greenway corridors.

Estimated project and/or units costs are as follows:

- Stream restoration and outfall channel stabilization: \$400/LF
- Bioretention, Pocket ponds, berm and riser installation: \$42,000/imp acre treated
- Swales, grass channels, bioswales, baffle installation: \$36,000/imp acre treated
- Shallow wetland/marsh or new ponds: \$50,000/imp acre treated
- Green Roofs \$20/SF
- Reforestation: \$20,000 per acre
- Boulevard : \$7,500 per tree box
- Pond retrofit: \$50,000 per acre

Construction costs for the stormwater management BMPs and outfall retrofits were based on similar recently constructed projects and institutional knowledge of green infrastructure costs. True costs of retrofits and restoration projects vary significantly with site conditions and may increase if additional effort is needed to prepare geotechnical reports, work around utilities or perform additional grading based on field elevations. A design fee estimate of 30% for the construction cost was used for each of the above construction activities.



---

## References

- Barbour, M.T., J. Gerritsen, B.D. Snyder, and J.B. Stribling. 1999. Rapid Bioassessment Protocols for Use in Streams and Wadeable Rivers: Periphyton, Benthic Macroinvertebrates and Fish, Second Edition. EPA 841-B-99-002. U.S. Environmental Protection Agency; Office of Water; Washington, D.C.
- Bettinger, J., J. Crane, and J. Bulak. 2006. Piedmont Stream Survey – Broad River Basin. South Carolina Department of Natural Resources. Columbia, SC.
- City of Columbia. 2016. A Brief History of the City of Columbia. City of Columbia. Available online at: <https://www.columbiasc.net/about-columbia> Accessed 1/7/2016.
- Craft, S. 1994. Changing Minds, Opening Doors: A South Carolina Perspective on Mental Health Care. South Carolina Department of Mental Health. Columbia, SC.
- Environmental Protection Agency. 2016. Storm Water Management Model. V. 5.1.010. Available online at: <https://www.epa.gov/water-research/storm-water-management-model-swmm>. Accessed 5/1/2016.
- Federal Emergency Management Agency. 1994. Flood Insurance Study, Richland County, South Carolina, and Incorporated Areas. Washington, D.C. January 19, 1994.
- Federal Emergency Management Agency. 2010. Flood Insurance Study, Richland County, South Carolina, and Incorporated Areas. Washington, D.C. September 29, 2010.
- Federal Emergency Management Agency. 2015. Preliminary Flood Insurance Study, Richland County, South Carolina, and Incorporated Areas. Washington, D.C. April 30, 2015.
- Griffith, G.E., Omernik, J.M., Comstock, J.A., Schafale, M.P., McNab, W.H., Lenat, D.R., MacPherson, T.F., Glover, J.B., and Shelburne, V.B., 2002, Ecoregions of North Carolina and South Carolina, (color poster with map, descriptive text, summary tables, and photographs): Reston, Virginia, U.S. Geological Survey (map scale 1:1,500,000).
- Guimares, W. B. and T. D. Feaster. 2001. Estimating the Magnitude and Frequency of Floods in Small Urban Streams in South Carolina. U.S. Geological Survey Scientific Investigations Report 2004-5030, 67 pages (Published 2004).
- Schueler, T. R. 2005. An Integrated Framework to Restore Small Urban Watersheds. V. 2.0. Center for Watershed Protection. Ellicott City, MD.
- South Carolina Department of Health and Environmental Control. 2005. Total Maximum Daily Loads for Fecal Coliform for Turkey Creek, Meng Creek, Browns Creek, Gregorys Creek, Dry Fork, Sandy River, Elizabeth Lake, Little River, Winnsboro Branch, Jackson Creek, and Mill Creek watersheds and the Lower portion of the Upper Broad River, South Carolina. South Carolina Department of Health and Environmental Control Technical Report Number 028-05.



---

South Carolina Department of Natural Resources. 2005. 2005 Comprehensive Wildlife Conservation Strategy. South Carolina Department of Natural Resources. Columbia, SC.

United States Army Corps of Engineers Hydrologic Engineering Center. 2010. River Analysis System HEC-RAS. V.4.1.0 [Computer software]. Available online at: <http://www.hec.usace.army.mil/software/hec-ras/downloads.aspx>. Accessed 5/1/2016.

United States Department of Agriculture Soil Conservation Service. 1978. Soil Survey of Richland County, South Carolina. Natural Resource Conservation Service. Washington, D.C.

United States Department of Agriculture Natural Resource Conservation Service. 2016. Web Soil Survey for Richland County, SC. Natural Resources Conservation Service, United States Department of Agriculture. Available online at <http://websoilsurvey.nrcs.usda.gov>. Accessed 2/1/2016.

United States Geological Survey. 2011. Methods for Estimating the Magnitude and Frequency of Floods for Urban and Small, Rural Streams in Georgia, South Carolina, and North Carolina. U.S. Geological Survey Scientific Investigations Report 2014–5030. Version 1.1, March 2014.

---

# Appendix A: Historic Aerial Photos

---



Smith Branch Watershed 1938



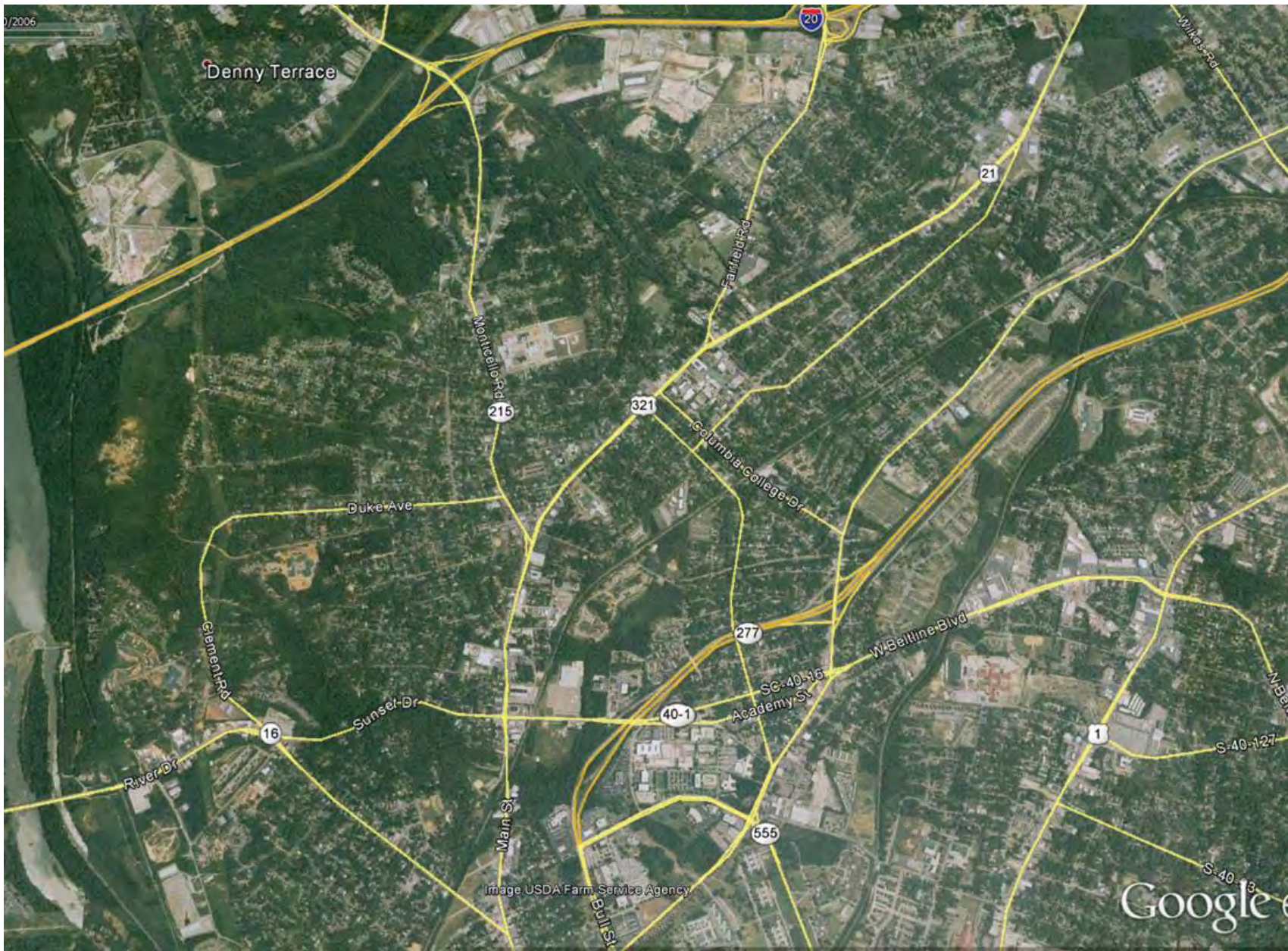
Smith Branch Watershed 1959



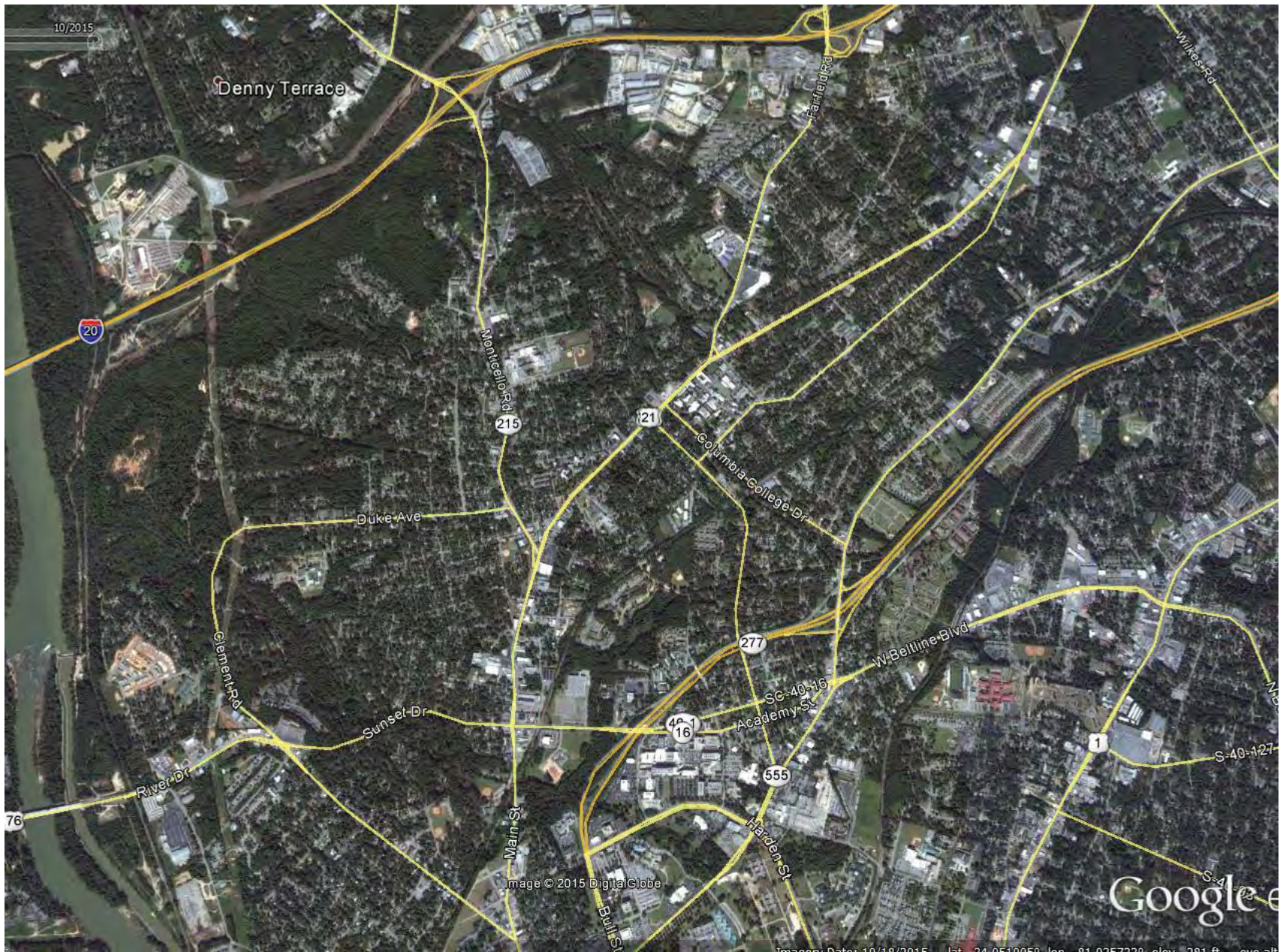
Smith Branch Watershed 1970



Smith Branch Watershed 1995



Smith Branch Watershed 2006



Smith Branch Watershed 2015



1938



1959



1970



1995

Smith Branch Watershed  
Region of Former South Carolina Lunatic Asylum

---

Appendix B:  
Field Data Dictionary  
(Stream Cruising Effort)

---

## Rocky Branch Watershed Data Dictionary

February 4<sup>th</sup>, 2016

### Example Attribute

#### **Feature Type (point or line)**

Attributes (text entry \_\_\_ and *drop down menus*)

**Red** means default

#### **Site Data (point)**

Site ID \_\_\_\_\_

Team Members \_\_\_\_\_

Current Weather (drop down menu)

*Sun*

*Clouds*

*Rain*

*Snow*

Current Temperature \_\_\_\_\_

Rain Previous 24hr (drop down menu)

*Yes, No*

If yes, amount in inches \_\_\_\_\_

Rain Previous 48hr y/n (drop down menu)

*Yes, No*

If yes, amount in inches \_\_\_\_\_

Rain Previous 72hr y/n (drop down menu)

*Yes, No*

If yes, amount in inches \_\_\_\_\_

#### **Channel Alteration (line)**

Site ID \_\_\_\_\_

Type (drop down menu)

*Concrete*

*Riprap*

*Gabion Basket*

*Earthen Channel*

*Channelization/Straightening*

*Road Culvert*

*Other (fill out comment)*

Comment on Type \_\_\_\_\_

Bottom Width \_\_\_\_\_

Pipe Diameter (inside) in Inches \_\_\_\_\_

Longitudinal Length in Feet \_\_\_\_\_

Alteration Location (drop down menu)

*Bed*

*Banks*

*Bed and Banks*

Flow Regime (drop down menu)

*Perennial*

*Intermittent*

*Ephemeral*

Significant vegetation in channel (drop down menu)

*Yes, No*

Significant Aggradation (drop down menu)

*Yes, No*

Significant Degradation (drop down menu)

*Yes, No*

Comment on Condition \_\_\_\_\_

Part of Road Crossing (drop down menu)

*Yes, No*

Severity (drop down menu)

*Very Severe*

*Severe*

*Moderate*

*Minor*

*Very Minor*

Estimated Difficulty to Correct (drop down menu)

*Very Hard*

*Hard*

*Moderate*

*Easy*

Very Easy  
Access (drop down menu)  
Very Hard  
Hard  
Moderate  
Easy  
Very Easy  
Photos (attached to feature)  
Comments\_\_\_\_\_

**Erosion Site (line)**

Site ID \_\_\_\_\_  
Type (drop down menu)  
Headcutting  
Downcutting  
Widening  
Other (fill out comment)  
Comment \_\_\_\_\_  
Suspected Cause (drop down menu)  
Pipe Outfall  
Bend at steep slope  
Landuse change  
Channel encroachment  
Unknown  
Other (fill out comment)  
Comment \_\_\_\_\_  
Longitudinal length in feet \_\_\_\_\_  
Average height in feet \_\_\_\_\_  
Left Land Use (Dominant land use on left side within  
50 feet)  
(drop down menu)  
Residential Development  
Commercial Development

Park/Open Space  
Paved  
Small Trees/Shrubs  
Forest  
Other (fill out comment)  
Comment \_\_\_\_\_  
Right Land Use (Dominant land use on right side  
within 50 feet)  
(drop down menu)  
Residential Development  
Commercial Development  
Park/Open Space  
Paved  
Small Trees/Shrubs  
Forest  
Other (fill out comment)  
Comment \_\_\_\_\_  
Infrastructure Possibly Threatened (drop down menu)  
Yes, *No*, Unknown  
Comment on Threat \_\_\_\_\_  
Predominant Bank Material (drop down menu)  
Clay  
*Silt*  
Sand  
Gravel  
Cobble  
Boulder  
Bedrock  
Stratification of Soils In bank (drop down menu)  
Yes, *no*  
Bank Angle (drop down menu)  
0 – 20 degrees  
21 – 60 degrees

61 – 80 degrees  
81 – 90 degrees  
91 - 119 degrees  
>119 degrees  
Severity (drop down menu)  
*Very Severe*  
*Severe*  
*Moderate*  
*Minor*  
*Very Minor*  
Estimated Difficulty to Correct (drop down menu)  
*Very Hard*  
*Hard*  
*Moderate*  
*Easy*  
*Very Easy*  
Access (drop down menu)  
*Very Hard*  
*Hard*  
*Moderate*  
*Easy*  
*Very Easy*  
Photos (attached to feature)  
Comments\_\_\_\_\_

**Exposed Pipes (point)**

Site ID\_\_\_\_\_

Type (drop down menu)  
*Manhole Stack*  
*Exposed along stream bank*  
*Pipe Crossing Channel*  
*Spanning Above Channel*  
*Other (fill out comment)*

Comment on Type\_\_\_\_\_

Material (drop down menu)  
*Concrete*  
*Brick*  
*Smooth Metal*  
*Corrugated Metal*  
*Corrugated Plastic*  
*Other (fill out comment)*

Comment on Material\_\_\_\_\_

Pipe Diameter (Inside) in Inches\_\_\_\_\_

Length of Pipe Exposed in Feet\_\_\_\_\_

Encasement (drop down menu)  
*Yes, No, Unknown*

Utility Type (drop down menu)  
*Sanitary*  
*Gas*  
*Water*  
*Other (fill out comment)*

Comment on Type\_\_\_\_\_

Evidence of Discharge (drop down menu)  
*Yes, No, Unknown*  
*Color and Odor*\_\_\_\_\_

Severity (drop down menu)  
*Very Severe*  
*Severe*  
*Moderate*  
*Minor*  
*Very Minor*

Estimated Difficulty to Correct (drop down menu)  
*Very Hard*  
*Hard*  
*Moderate*  
*Easy*

*Very Easy*  
Access (drop down menu)  
*Very Hard*  
*Hard*  
*Moderate*  
*Easy*  
*Very Easy*  
Photos (attached to feature)  
Comments\_\_\_\_\_

**Pipe Outfalls (point)**

Site ID \_\_\_\_\_  
Included in City GIS Layers? (drop down menu)  
*Yes, No*  
Type (drop down menu)  
*Storm Water Outfall*  
*Sewage Plant Discharge*  
*Industrial Discharge*  
*Overflow Pipe*  
*Agricultural Drainage Pipe*  
*Residential (Roof Drains)*  
*Unknown (fill out comment)*  
Comment on Type \_\_\_\_\_  
Material (drop down menu)  
*Concrete*  
*Smooth metal*  
*Corrugated Metal*  
*Corrugated Plastic*  
*Other (fill out comment)*  
Comment on Material \_\_\_\_\_  
Pipe Diameter (Inside) in Inches \_\_\_\_\_  
Location (drop down menu)  
*Left Bank*

*Right Bank*  
*Head of Channel*  
Headwall present? (drop down menu)  
*Yes, no*  
End section present? (drop down menu)  
*Yes, no*  
Outfall Structure in obvious need of repairs? (drop  
down menu)  
*Yes, No*  
Outfall Channel Width in Feet \_\_\_\_\_  
Outfall Channel Material (drop down menu)  
*Concrete*  
*Earthen*  
*Riprap*  
*Gabion*  
*Other (fill out comment)*  
Comment on Channel Material \_\_\_\_\_  
Evidence of Discharge (drop down menu)  
*Yes, No*  
Discharge Color \_\_\_\_\_  
Discharge Odor \_\_\_\_\_  
Evidence of Erosion (drop down menu)  
*Yes, No*  
Erosion Type (drop down menu)  
*Headcutting*  
*Downcutting*  
*Widening*  
*Other (fill out comment)*  
Comment on Erosion Type \_\_\_\_\_  
Distance from mainstem channel in Feet \_\_\_\_\_  
Vertical Drop outfall invert to mainstem invert in  
Feet \_\_\_\_\_  
Severity (drop down menu)

*Very Severe*  
*Severe*  
*Moderate*  
*Minor*  
*Very Minor*  
Estimated Difficulty to Correct (drop down menu)  
*Very Hard*  
*Hard*  
*Moderate*  
*Easy*  
*Very Easy*  
Access (drop down menu)  
*Very Hard*  
*Hard*  
*Moderate*  
*Easy*  
*Very Easy*  
Photos (attached to feature)  
Comments\_\_\_\_\_

**Possible Fish Barrier (point)** (Permanent only, Greater than 6" drop in WSEL, water depth less than 1", water moving too fast, Assessed at baseflow)

Site ID\_\_\_\_\_

Blockage Extent (drop down menu)  
*Total*  
*Partial*

Type (drop down menu)  
*Dam*  
*Road Crossing*  
*Pipe Crossing*  
*Natural Falls*  
*Beaver Dam*

*Channelized Stream Section*  
*Other (fill out comment)*  
Comment on Type \_\_\_\_\_  
Blockage Because (Choose Most Important) (drop down menu)

*Too high (>6", Height)*  
*Too Shallow (<1")*  
*Too Fast*  
Water Drop in Inches\_\_\_\_\_

Water Depth in Feet\_\_\_\_\_

Severity (drop down menu)  
*Very Severe*  
*Severe*  
*Moderate*  
*Minor*  
*Very Minor*

Estimated Difficulty to Correct (drop down menu)  
*Very Hard*  
*Hard*  
*Moderate*  
*Easy*  
*Very Easy*

Access (drop down menu)  
*Very Hard*  
*Hard*  
*Moderate*  
*Easy*  
*Very Easy*

Photos (attached to feature)  
Comments\_\_\_\_\_

**Inadequate Forest Buffer (line)** (<50 feet forest buffer)  
Site ID\_\_\_\_\_

Existing Buffer Width - Right \_\_\_\_\_

Existing Buffer Width - Left \_\_\_\_\_

Landuse Right Bank (drop down menu)

*Residential Building*

*Commercial Building*

*Park/Open Space*

*Paved*

*Small Trees/Shrubs*

*Forest*

*Other (fill out comment)*

Landuse Left Bank (drop down menu)

*Residential Building*

*Commercial Building*

*Park/Open Space*

*Paved*

*Small Trees/Shrubs*

*Forest*

*Other (fill out comment)*

Comment on Landuse \_\_\_\_\_

Recent Buffer Establishment (drop down menu)

*Yes, No*

Comment on Recent Establishment \_\_\_\_\_

Possible Opportunity for Tree Planting? (drop down menu)

*Yes, No*

Severity (drop down menu)

*Very Severe*

*Severe*

*Moderate*

*Minor*

*Very Minor*

Estimated Difficulty to Correct (drop down menu)

*Very Hard*

*Hard*

*Moderate*

*Easy*

*Very Easy*

Access (drop down menu)

*Very Hard*

*Hard*

*Moderate*

*Easy*

*Very Easy*

Wetland Potential (drop down menu)

*Very Hard*

*Hard*

*Moderate*

*Easy*

*Very Easy*

Photos (attached to feature)

Comments \_\_\_\_\_

**In/Near Stream Construction (Point)**

Site ID \_\_\_\_\_

Type of Activity (drop down menu)

*Road Construction*

*Culvert/Bridge work*

*Utility Work*

*Clearing*

*Bank Stabilization*

*Residential Development*

*Industrial Development*

*Other (fill out comment)*

Comment on Activity Type \_\_\_\_\_

Photos (attached to feature)

Comments \_\_\_\_\_

**Trash Dumping (Point)**

- Site ID \_\_\_\_\_
- Type of Trash (drop down menu)
  - Residential*
  - Industrial*
  - Floatables*
  - Tires*
  - Construction Waste*
- Distribution (drop down menu)
  - Single Site*
  - Multiple Sites*
- Location (drop down menu)
  - Instream*
  - Bank*
  - Floodplain*
- Amount of Trash (Estimate number of pickup loads) \_\_\_\_\_
- Volunteer Clean-up Potential? (drop down menu)
  - Yes, No*
- Severity (drop down menu)
  - Very Severe*
  - Severe*
  - Moderate*
  - Minor*
  - Very Minor*
- Estimated Difficulty to Correct (drop down menu)
  - Very Hard*
  - Hard*
  - Moderate*
  - Easy*

- Very Easy*
- Access (drop down menu)
  - Very Hard*
  - Hard*
  - Moderate*
  - Easy*
  - Very Easy*
- Photos (attached to feature)
- Comments \_\_\_\_\_

**Unusual Condition (Point)**

- Site ID \_\_\_\_\_
- Type (drop down menu)
  - Unusual odor*
  - Excessive algae/scum*
  - Unusual water color/clarity*
  - Excessive bacteria indicators*
  - Stream restoration by landowner*
  - Plantings*
  - Other (fill out comment)*
- Comment on Type \_\_\_\_\_
- Severity (drop down menu)
  - Very Severe*
  - Severe*
  - Moderate*
  - Minor*
  - Very Minor*
- Estimated Difficulty to Correct (drop down menu)
  - Very Hard*
  - Hard*
  - Moderate*
  - Easy*
  - Very Easy*

Access (drop down menu)  
*Very Hard*  
*Hard*  
*Moderate*  
*Easy*  
*Very Easy*  
Photos (attached to feature)  
Comments\_\_\_\_\_

*Very Easy*  
Access (drop down menu)  
*Very Hard*  
*Hard*  
*Moderate*  
*Easy*  
*Very Easy*  
Photos (attached to feature)  
Comments\_\_\_\_\_

**Unmanaged Runoff (Point)**

Date\_\_\_\_\_

Team\_\_\_\_\_

Site\_\_\_\_\_

Time\_\_\_\_\_

Source (drop down menu)  
*Parking Lot*  
*Road*  
*Commercial Development*  
*Other (fill out comment)*

Comment on Source\_\_\_\_\_

Potential BMP Opportunity?  
*Yes, No*

Severity (drop down menu)  
*Very Severe*  
*Severe*  
*Moderate*  
*Minor*  
*Very Minor*

Estimated Difficulty to Correct (drop down menu)  
*Very Hard*  
*Hard*  
*Moderate*  
*Easy*

**Bedrock (point)**

Site ID\_\_\_\_\_

Location (drop down menu)  
*In-Channel*  
*Right Bank*  
*Left Bank*  
*Other*\_\_\_\_\_

Associated Bed Feature (drop down menu)  
*Pool*  
*Riffle*  
*Run*  
*Cascade*  
*Glide*  
*Other (fill out comment)*

Photos (attached to feature)  
Comments\_\_\_\_\_

**Representative Photo Site (point)**

Site ID\_\_\_\_\_

Valley/Channel Change Type (drop down menu)  
*Entrenchment*  
*Buffer Condition*  
*Channel Width*

*Bank height*

*Floodplain*

*Valley*

*Sinosity*

*Bed Material*

*Other* (fill out comment)

Photos (attached to feature)

Comments \_\_\_\_\_

**Habitat Assessment (point) – Based on EPA RBP**

(See pages 11 and 12 for descriptions of conditions categories)

Site ID \_\_\_\_\_

Bed Particle Size - % clay \_\_\_\_\_

Bed Particle Size - % silt \_\_\_\_\_

Bed Particle Size - % sand \_\_\_\_\_

Bed Particle Size - % gravel \_\_\_\_\_

Bed Particle Size - % cobble \_\_\_\_\_

Bed Particle Size - % boulder \_\_\_\_\_

Bed Particle Size - % bedrock \_\_\_\_\_

Bed Particle Size - % concrete \_\_\_\_\_

Epifaunal Substrate/Available Cover (0-20) \_\_\_\_\_

Embeddedness (0-20) \_\_\_\_\_

Velocity/Depth Regime (0-20) \_\_\_\_\_

Sediment Deposition (0-20) \_\_\_\_\_

Channel Flow Status (0-20) \_\_\_\_\_

Channel Alteration (0-20) \_\_\_\_\_

Frequency of Riffles (or bends) (0-20) \_\_\_\_\_

Bank Stability (Right) (0-10) \_\_\_\_\_

Bank Stability (Left) (0-10) \_\_\_\_\_

Vegetative Protection (Right) (0-10) \_\_\_\_\_

Vegetative Protection (Left) (0-10) \_\_\_\_\_

Riparian Vegetative Width (Right) (0-10) \_\_\_\_\_

Riparian Vegetative Width (Left) (0-10) \_\_\_\_\_

Trash Rating (0-20)

Percent Shading (to nearest 10%, assuming leaf on)

Photos (attached to feature)

Comments \_\_\_\_\_

**Restoration Recommendation (polygon)**

Site ID \_\_\_\_\_

Severity (drop down menu)

*Very Severe*

*Severe*

*Moderate*

*Minor*

*Very Minor*

Estimated Difficulty to Correct (drop down menu)

*Very Hard*

*Hard*

*Moderate*

*Easy*

*Very Easy*

Access (drop down menu)

*Very Hard*

*Hard*

*Moderate*

*Easy*

*Very Easy*

Potential Constraint (select primary concern)

*Utilities*

*Existing infrastructure*

*Existing landuse*

*Access*

*Resource Impacts*

*Other* (fill out comment)

Comment on Constraints \_\_\_\_\_

Potential for Public Outreach and/or greenway  
connection

*Yes, no*

Photos (attached to feature)

Comments\_\_\_\_\_

Habitat Parameter	Condition Category			
	Optimal	Suboptimal	Marginal	Poor
<b>1. Epifaunal Substrate/ Available Cover</b>	Greater than 70% of substrate favorable for epifaunal colonization and fish cover; mix of snags, submerged logs, undercut banks, cobble or other stable habitat and at stage to allow full colonization potential (i.e., logs/snags that are <u>not</u> new fall and <u>not</u> transient).	40-70% mix of stable habitat; well-suited for full colonization potential; adequate habitat for maintenance of populations; presence of additional substrate in the form of newfall, but not yet prepared for colonization (may rate at high end of scale).	20-40% mix of stable habitat; habitat availability less than desirable; substrate frequently disturbed or removed.	Less than 20% stable habitat; lack of habitat is obvious; substrate unstable or lacking.
SCORE	20 19 18 17 16	15 14 13 12 11	10 9 8 7 6	5 4 3 2 1 0
<b>2. Embeddedness</b>	Gravel, cobble, and boulder particles are 0-25% surrounded by fine sediment. Layering of cobble provides diversity of niche space.	Gravel, cobble, and boulder particles are 25-50% surrounded by fine sediment.	Gravel, cobble, and boulder particles are 50-75% surrounded by fine sediment.	Gravel, cobble, and boulder particles are more than 75% surrounded by fine sediment.
SCORE	20 19 18 17 16	15 14 13 12 11	10 9 8 7 6	5 4 3 2 1 0
<b>3. Velocity/Depth Regime</b>	All four velocity/depth regimes present (slow-deep, slow-shallow, fast-deep, fast-shallow). (Slow is < 0.3 m/s, deep is > 0.5 m.)	Only 3 of the 4 regimes present (if fast-shallow is missing, score lower than if missing other regimes).	Only 2 of the 4 habitat regimes present (if fast-shallow or slow-shallow are missing, score low).	Dominated by 1 velocity/depth regime (usually slow-deep).
SCORE	20 19 18 17 16	15 14 13 12 11	10 9 8 7 6	5 4 3 2 1 0
<b>4. Sediment Deposition</b>	Little or no enlargement of islands or point bars and less than 5% of the bottom affected by sediment deposition.	Some new increase in bar formation, mostly from gravel, sand or fine sediment; 5-30% of the bottom affected; slight deposition in pools.	Moderate deposition of new gravel, sand or fine sediment on old and new bars; 30-50% of the bottom affected; sediment deposits at obstructions, constrictions, and bends; moderate deposition of pools prevalent.	Heavy deposits of fine material, increased bar development; more than 50% of the bottom changing frequently; pools almost absent due to substantial sediment deposition.
SCORE	20 19 18 17 16	15 14 13 12 11	10 9 8 7 6	5 4 3 2 1 0
<b>5. Channel Flow Status</b>	Water reaches base of both lower banks, and minimal amount of channel substrate is exposed.	Water fills >75% of the available channel; or <25% of channel substrate is exposed.	Water fills 25-75% of the available channel, and/or riffle substrates are mostly exposed.	Very little water in channel and mostly present as standing pools.
SCORE	20 19 18 17 16	15 14 13 12 11	10 9 8 7 6	5 4 3 2 1 0
<b>6. Channel Alteration</b>	Channelization or dredging absent or minimal; stream with normal pattern.	Some channelization present, usually in areas of bridge abutments; evidence of past channelization, i.e., dredging, (greater than past 20 yr) may be present, but recent channelization is not present.	Channelization may be extensive; embankments or shoring structures present on both banks; and 40 to 80% of stream reach channelized and disrupted.	Banks shored with gabion or cement; over 80% of the stream reach channelized and disrupted. Instream habitat greatly altered or removed entirely.
SCORE	20 19 18 17 16	15 14 13 12 11	10 9 8 7 6	5 4 3 2 1 0

Parameters to be evaluated in sampling reach

Habitat Parameter	Condition Category				
	Optimal	Suboptimal	Marginal	Poor	
<b>7. Frequency of Riffles (or bends)</b>	Occurrence of riffles relatively frequent; ratio of distance between riffles divided by width of the stream <7:1 (generally 5 to 7); variety of habitat is key. In streams where riffles are continuous, placement of boulders or other large, natural obstruction is important.	Occurrence of riffles infrequent; distance between riffles divided by the width of the stream is between 7 to 15.	Occasional riffle or bend; bottom contours provide some habitat; distance between riffles divided by the width of the stream is between 15 to 25.	Generally all flat water or shallow riffles; poor habitat; distance between riffles divided by the width of the stream is a ratio of >25.	
	SCORE	20 19 18 17 16	15 14 13 12 11	10 9 8 7 6	5 4 3 2 1 0
<b>8. Bank Stability (score each bank)</b>  Note: determine left or right side by facing downstream.	Banks stable; evidence of erosion or bank failure absent or minimal; little potential for future problems. <5% of bank affected.	Moderately stable; infrequent, small areas of erosion mostly healed over. 5-30% of bank in reach has areas of erosion.	Moderately unstable; 30-60% of bank in reach has areas of erosion; high erosion potential during floods.	Unstable; many eroded areas; "raw" areas frequent along straight sections and bends; obvious bank sloughing; 60-100% of bank has erosional scars.	
	SCORE ___ (LB)	Left Bank 10 9	8 7 6	5 4 3	2 1 0
	SCORE ___ (RB)	Right Bank 10 9	8 7 6	5 4 3	2 1 0
<b>9. Vegetative Protection (score each bank)</b>	More than 90% of the streambank surfaces and immediate riparian zone covered by native vegetation, including trees, understory shrubs, or nonwoody macrophytes; vegetative disruption through grazing or mowing minimal or not evident; almost all plants allowed to grow naturally.	70-90% of the streambank surfaces covered by native vegetation, but one class of plants is not well-represented; disruption evident but not affecting full plant growth potential to any great extent; more than one-half of the potential plant stubble height remaining.	50-70% of the streambank surfaces covered by vegetation; disruption obvious; patches of bare soil or closely cropped vegetation common; less than one-half of the potential plant stubble height remaining.	Less than 50% of the streambank surfaces covered by vegetation; disruption of streambank vegetation is very high; vegetation has been removed to 5 centimeters or less in average stubble height.	
	SCORE ___ (LB)	Left Bank 10 9	8 7 6	5 4 3	2 1 0
	SCORE ___ (RB)	Right Bank 10 9	8 7 6	5 4 3	2 1 0
<b>10. Riparian Vegetative Zone Width (score each bank riparian zone)</b>	Width of riparian zone >18 meters; human activities (i.e., parking lots, roadbeds, clear-cuts, lawns, or crops) have not impacted zone.	Width of riparian zone 12-18 meters; human activities have impacted zone only minimally.	Width of riparian zone 6-12 meters; human activities have impacted zone a great deal.	Width of riparian zone <6 meters; little or no riparian vegetation due to human activities.	
	SCORE ___ (LB)	Left Bank 10 9	8 7 6	5 4 3	2 1 0
	SCORE ___ (RB)	Right Bank 10 9	8 7 6	5 4 3	2 1 0

Habitat Parameter	Optimal 16-20	Sub-Optimal 11-15	Marginal 6-10	Poor 0-5
<b>Trash Rating</b>	Little or no human refuse visible from stream channel or riparian zone	Refuse present in minor amounts	Refuse present in moderate amounts	Refuse abundant and unsightly

---

# Appendix C: Water Quality Data

---



## TECHNICAL MEMORANDUM

**TO:** McCormick Taylor, Inc.

**FROM:** KCI Technologies, Inc.

**DATE:** March 15, 2016

**SUBJECT:** Smith Branch Watershed – Water Quality Analysis and Recommendations  
KCI Job Order No. 171600276

---

Smith Branch is a small urban watershed located in Columbia, South Carolina. The watershed is approximately 7.4 miles<sup>2</sup> and contains residential and commercial development. It is also one of the most significant flood hazard areas in Columbia. The floodplains are mostly undeveloped, but development is expected. Floodplain management information is needed to prevent unwise use of the floodplains. Smith Branch is a part of the Lower Broad River Watershed and is the most downstream tributary to the Broad River. The Lower Broad River has an established Total Maximum Daily Load (TMDL) for fecal coliform (*E. coli*). The City of Columbia has developed a TMDL Monitoring and Assessment Plan for the Smith Branch Watershed because a majority of the city's MS4 boundary that is located within this TMDL watershed drains to Smith Branch. Water quality monitoring in Smith Branch consists of two sites, Smith Branch A (SMIA), located near Main St. and Smith Branch B (SMIB), located near Clement Rd. A USGS stream gage (02162093) is located near SMA. The water quality monitoring activities are managed by the City of Columbia Stormwater Management.

### **Water Quality Analysis**

The following is KCI's analysis of available water quality data for Smith Branch in the vicinity of the City of Columbia, South Carolina. The purpose of the analysis is to compile available water quality data to assess current water quality conditions in the watershed and to determine if the existing monitoring program should be modified to meet the data needs of the City of Columbia to inform management decisions related to water quality regulations and public health criteria.

### Site SMIA

*In situ* water quality data were collected from the SMIA site using a recording sonde set to collect data every 15 minutes. The sonde collected pH, specific conductance, water temperature, dissolved oxygen, and turbidity data. *In situ* water quality data were available for the period starting June 12<sup>th</sup>, 2015 through November 15<sup>th</sup>, 2015.

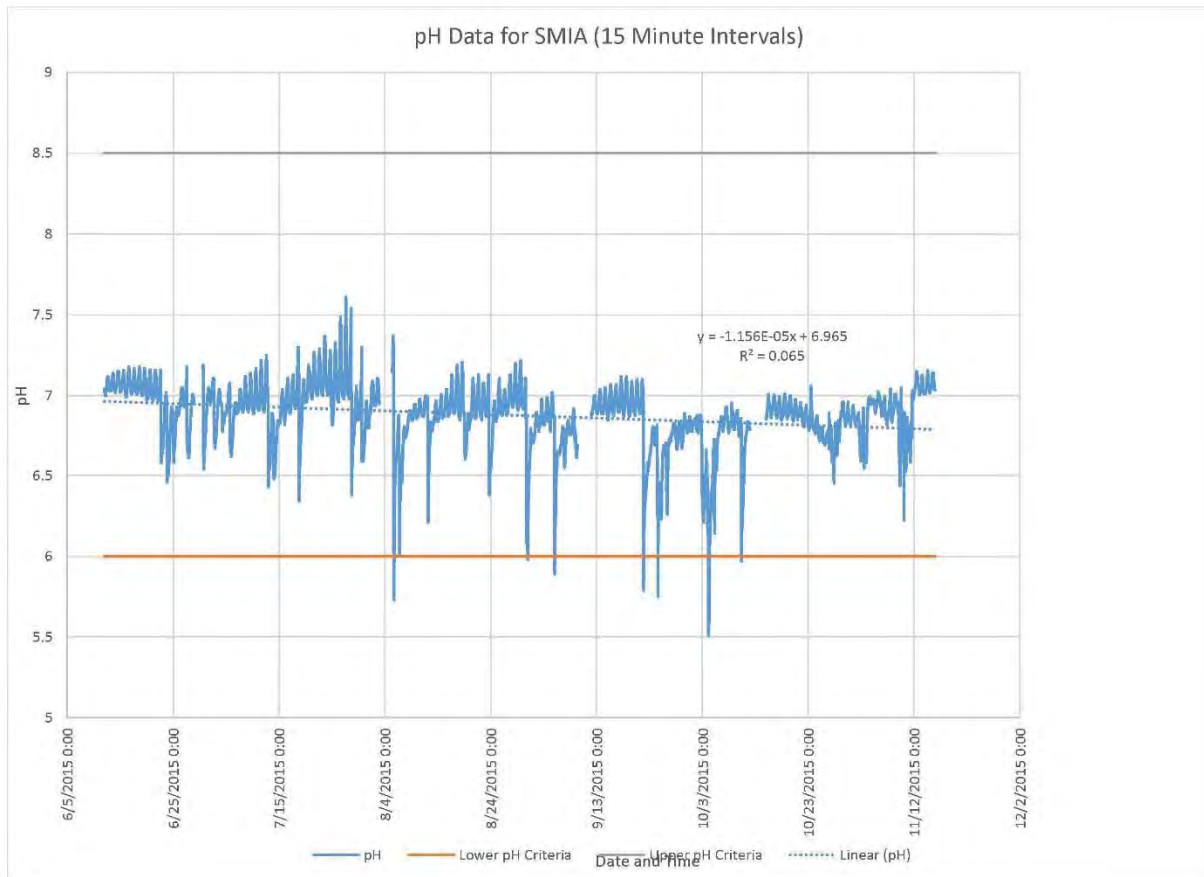
Water quality grab samples were collected four times on three days, August 18<sup>th</sup>, 2015, October 27<sup>th</sup>, 2015, and twice on January 15<sup>th</sup>, 2016. Each water quality grab samples were analyzed for *E. coli* (MPN/100 mL), and the October and January samples were also analyzed for TSS (mg/L), total phosphorus (mg/L), and total nitrogen (mg/L).

### *pH Analysis*

Water quality sonde data collected at 15-minute intervals from site SMIA show that the water quality standard for pH of an acceptable range of 6.0 to 8.5 pH was violated 0.34% of the time (48 out of 14,146 records) over the period of record. All of the excursions outside of the water quality standards were below 6.0; none of the pH values were above 8.5.

A linear regression analysis was performed for 15-minute interval pH data from SMIA. The results of the linear regression analysis show a slight negative slope (-1.1557E-05), which was significant at the  $p < 0.01$  level ( $p < 0.001$ ). This indicates that the likelihood of this decreasing pH relationship occurring by chance is very small. The negative slope of the line indicates that pH values are decreasing very slightly throughout this dataset. This rate of change is so small that changes in observed pH values would happen over several tens of thousands of measurements. If this relationship holds true with data collected over additional time periods, it would take over 2.5 years for a realized 1.0 decrease in pH value.

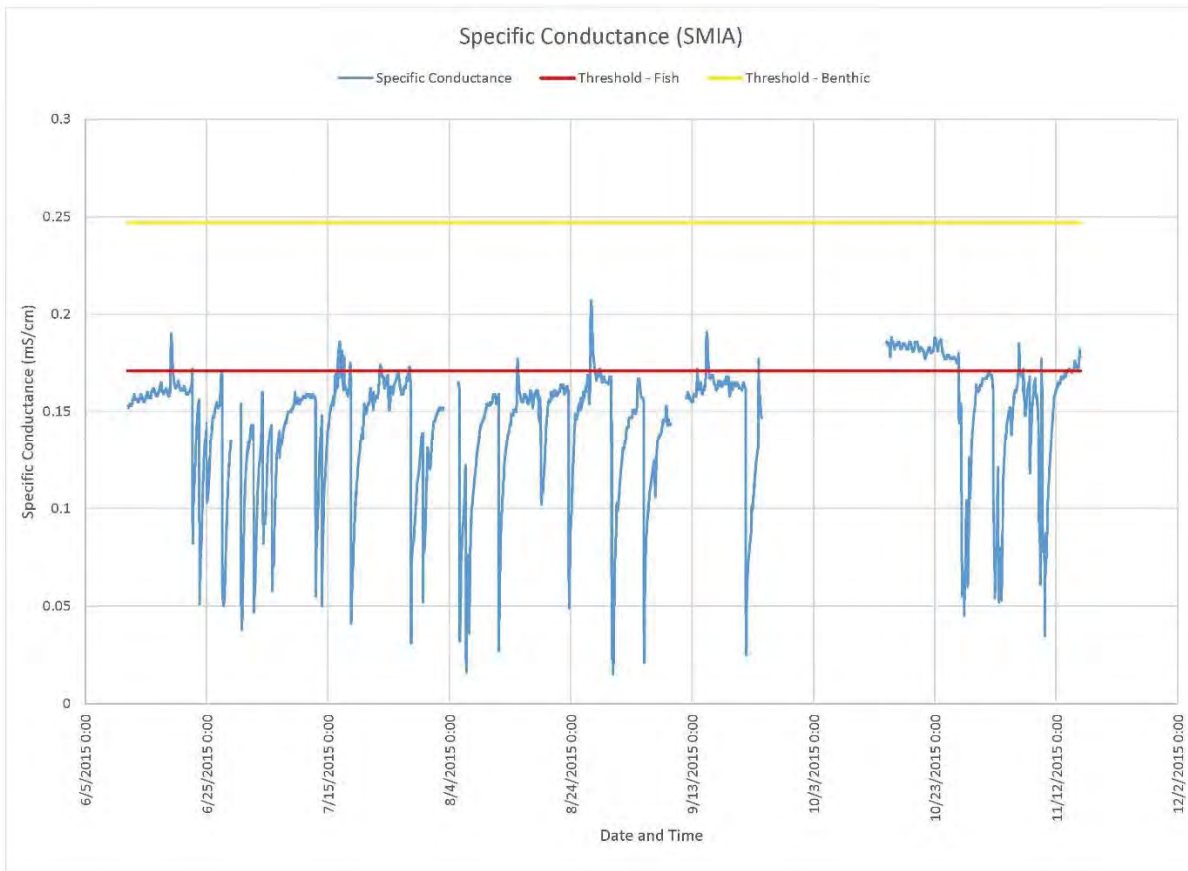
	<i>Coefficients</i>	<i>Standard Error</i>	<i>t Stat</i>	<i>P-value</i>
Intercept	6.965457692	0.003191	2183.154	0
Slope	-1.15569E-05	3.67E-07	-31.451	6.392E-210



Monthly average pH and seasonal average pH were not calculated for this site because there was only five months of data.

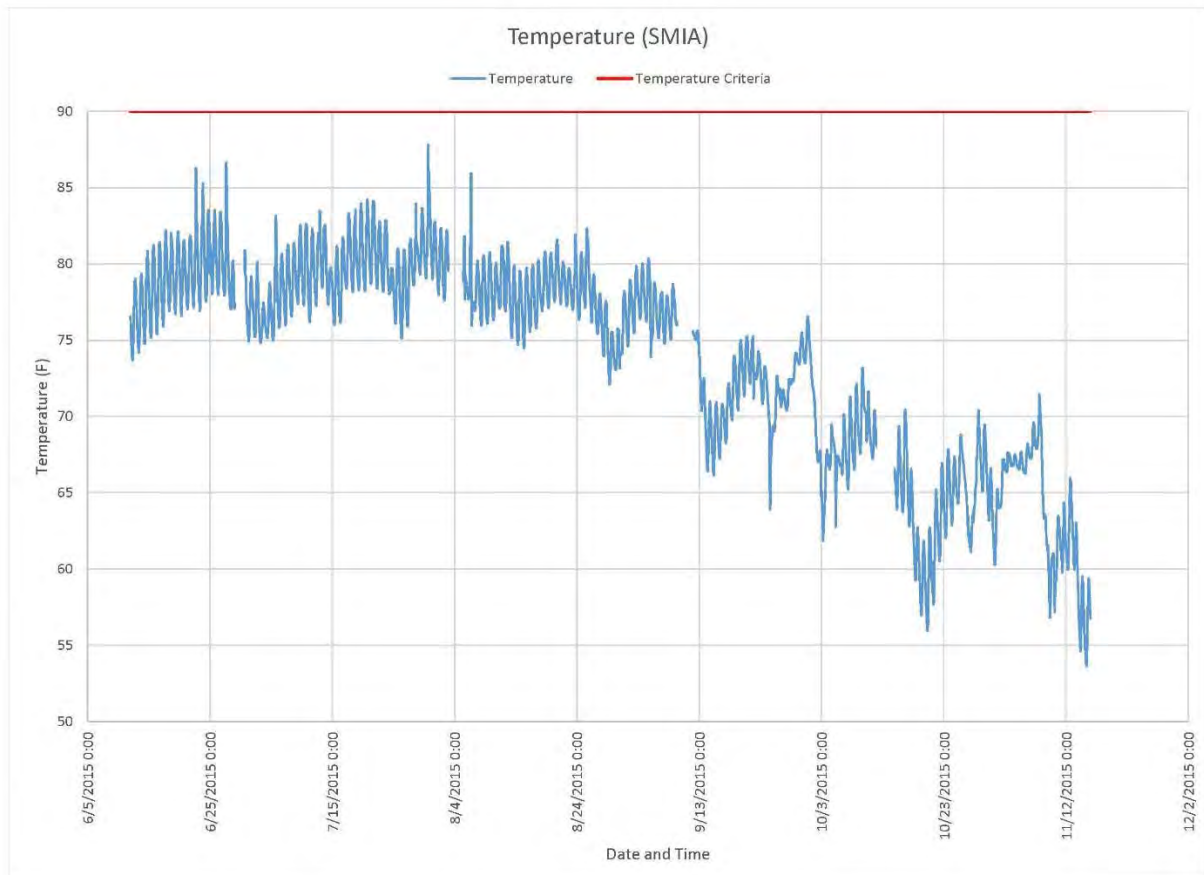
### *Specific Conductance*

South Carolina does not have water quality criteria for specific conductance, which is a measure of dissolved inorganic ions such as chloride, nitrate, sulfate and phosphate anions and sodium, magnesium, calcium, iron, and aluminum cations. Morgan et al., 2007, found biological assemblage impairment thresholds for biological impairment of 0.247 mS/cm for benthic macroinvertebrates and 0.171 mS/cm for fish in urban streams in Maryland. Smith Branch is an urban stream so the impairment thresholds from Maryland data may be applicable. When compared against these values, the possible specific conductance impairment thresholds were exceeded in SMIA for fish assemblage 13.99% of the time (1,744 records out of 12,465 total records). Specific conductance was not exceeded for benthic macroinvertebrates. Specific conductance data are missing for a large period of time starting September 24<sup>th</sup>, 2015 through October 14<sup>th</sup>, 2015. These missing data affected the analysis.



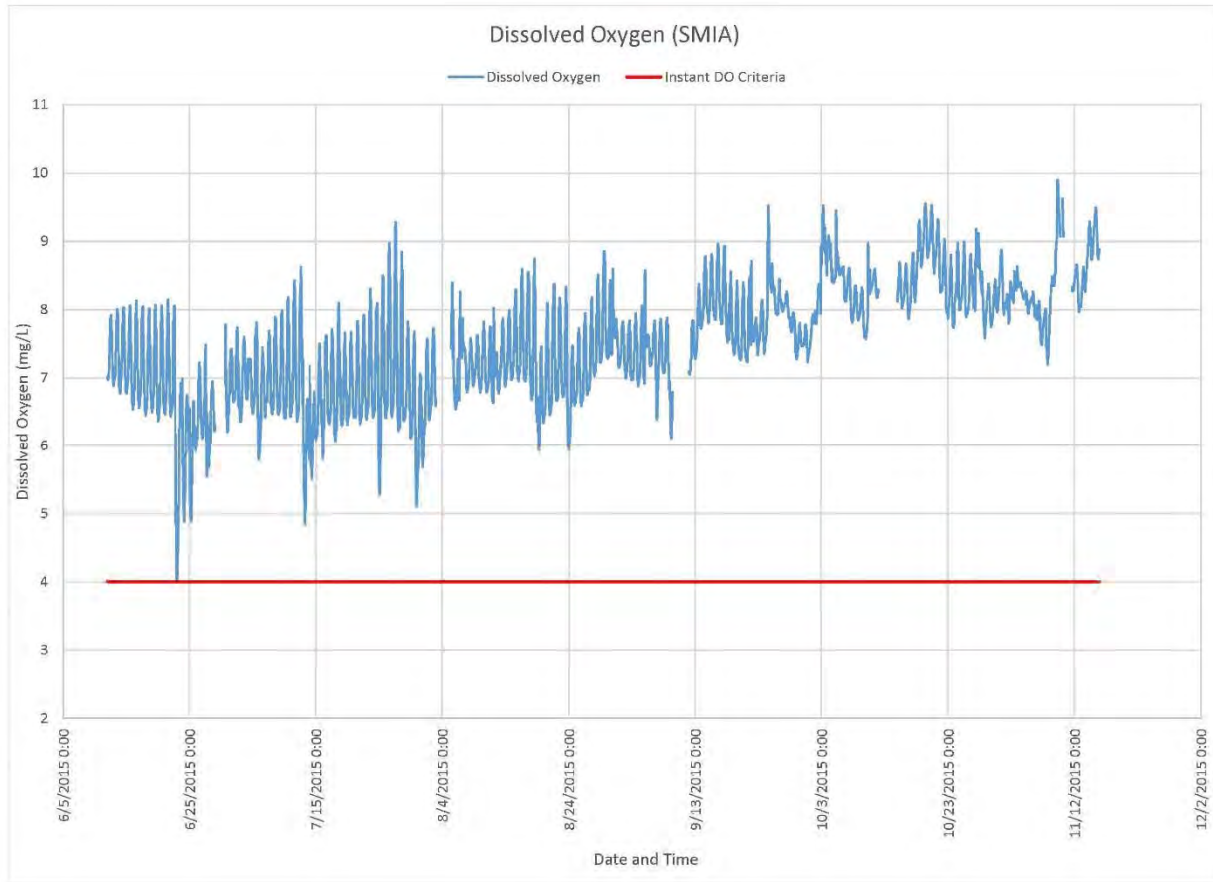
### *Water Temperature*

The water quality criteria for temperature of 90.0° F was not exceeded at SMIA. As expected, there is a seasonal and diurnal pattern to water temperature in Smith Branch. The highest measured water temperatures occurred during the summer time. Summer is the time of the year with the highest air temperatures, and the greatest amount of solar radiation. These factors help warm water throughout the day. The highest temperatures measured each day were in the afternoon. Afternoon is usually the period of time with the highest air temperature, and sunlight has been warming the water and stream substrates throughout the day.



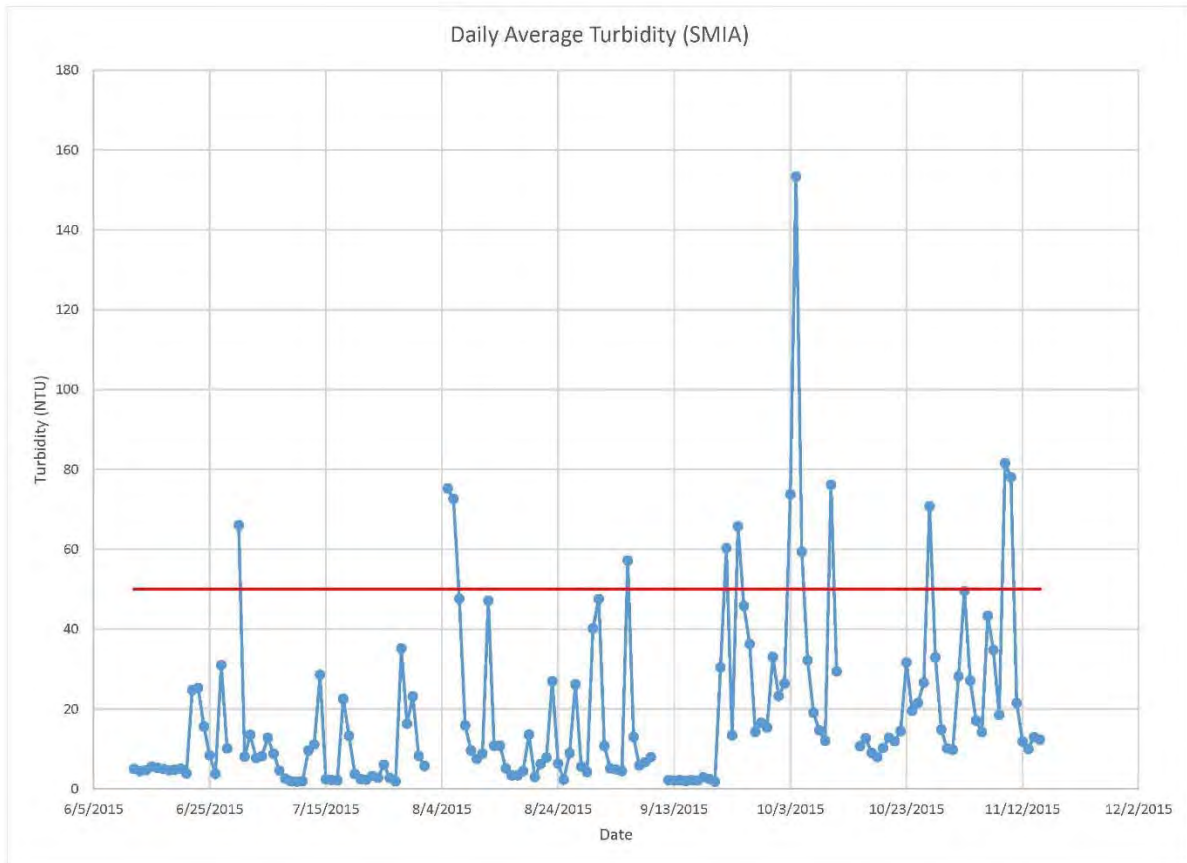
### *Dissolved Oxygen*

Water quality sonde data from site SMIA show that the instantaneous water quality standard for dissolved oxygen of 4.0 mg/L was not violated over the period of record (0 out of 13,986). Over the same period of time, the water quality standard for daily average dissolved oxygen of 5.0 mg/L was also not violated (0 out of 149 days). June 23<sup>rd</sup>, 2015 had the lowest observed daily average dissolved oxygen concentration of 5.82 mg/L.



### *Turbidity*

Results of turbidity data from the water quality sonde at SMIA show that the turbidity water quality standard of 50.0 NTU was exceeded 8.18% of the time (1122 records out of a total 13,713 records). High turbidity values were mostly seen during periods of intense rainfall when stormwater flow increases.



### *E. coli*

Water quality grab samples were collected four times at SMIA and analyzed for *E. coli*. Since there were only four samples over eight months there are too few samples to perform a trend analysis. *E. coli* counts ranged from a high of 14,540 MPN/100mL to a low of 316 MPN/100mL. The mean was  $6,593.0 \pm 9,482.6$  with a standard deviation of 5,959.3.

South Carolina's water quality standard for fecal coliform is a geometric mean of 200 MPN/100mL of five samples collected over a 30-day period. There is no 30-day period throughout the period of record for SMIA where at least five samples were collected. A comparison of means is not possible. The water quality criteria allow for a percentage criteria, where recreational uses are supported if less than 10% of samples exceed 400 MPN/100mL. At SMIA 75.0 % of available samples exceed 400 MPN/100 mL.

### *TSS*

Water quality grab samples were collected at SMIA and analyzed for TSS for 75% of the sampling events (3 of 4 events). These three TSS samples were collected during two days: one sample on October 27<sup>th</sup>, 2015 and two samples on January 15<sup>th</sup>, 2016. The TSS data are too infrequent to allow for any robust statistical analysis. TSS concentrations ranged from a high of 478 mg/L to a low of 136 mg/L. The mean concentration was  $311.7 \pm 425.3$  with a standard deviation of 171.2.

### *Total Phosphorus*

Water quality grab samples were collected at SMIA and analyzed for total phosphorus (TP) 3 out of 4 (75%) sampling events. These three TSS samples were collected during two days: one sample on October 27th, 2015 and two samples on January 15th, 2016. The TP data are too infrequent to allow for any robust statistical analysis. TP concentrations ranged from a high of 0.49 mg/L to a low of 0.28 mg/L. The mean concentration was  $0.387 \pm 0.261$  with a standard deviation of 0.105.

### *Total Nitrogen*

Water quality grab samples were collected at SMIA and analyzed for total nitrogen (TN) 3 out of 4 (75%) sampling events. These three TSS samples were collected during two days: one sample on October 27th, 2015 and two samples on January 15th, 2016. The TN data are too infrequent to allow for any robust statistical analysis. TN concentrations ranged from a high of 2.61 mg/L to a low of 1.30 mg/L. The mean concentration was  $1.87 \pm 1.67$  with a standard deviation of 0.67.

### *Site SMIB*

*In situ* water quality data were collected from the SMIB site using a recording sonde set to collect data every 15 minutes. The sonde collected pH, specific conductance, water temperature, dissolved oxygen, and turbidity data. *In situ* water quality data were available for the period starting June 12<sup>th</sup>, 2015 through November 15<sup>th</sup>, 2015.

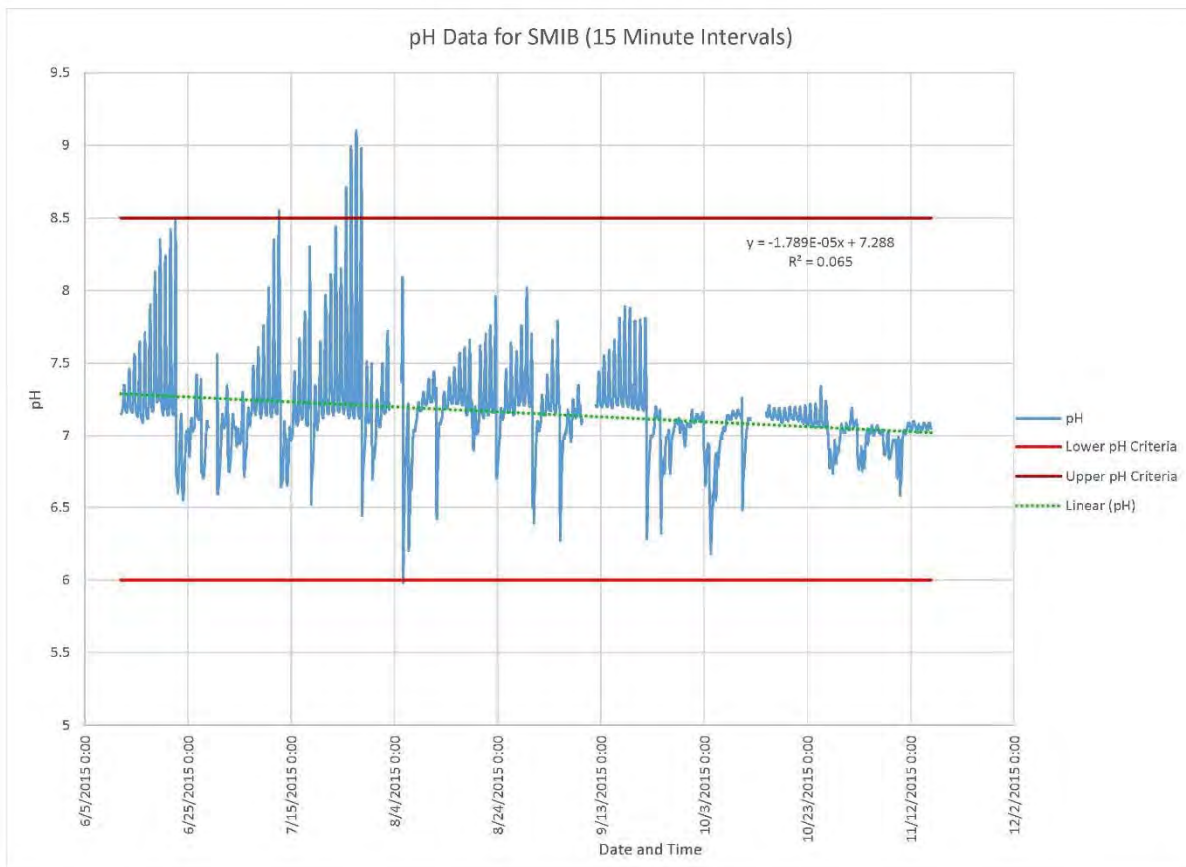
Water quality grab samples were collected four times on three days, August 18<sup>th</sup>, 2015, October 27<sup>th</sup>, 2015, and twice on January 15<sup>th</sup>, 2016. Each water quality grab samples were analyzed for *E. coli* (MPN/100 mL), and the October and January samples were also analyzed for TSS (mg/L), total phosphorus (mg/L), and total nitrogen (mg/L).

### *pH Analysis*

Water quality sonde data collected at 15-minute intervals from site SMIB show that the water quality standard for pH of an acceptable range of 6.0 to 8.5 pH was violated 0.01% of the time (1 out of 14,145 records) for a pH below 6.0 and 0.62% of the time (88 out of 14,145 records) for a pH above 8.5.

A linear regression analysis was performed for 15-minute interval pH data. The results of the linear regression analysis show a slight negative slope (-1.78904E-05), which was significant at the  $p < 0.01$  level ( $p < 0.001$ ). This indicates that the likelihood of this decreasing pH relationship occurring by chance is very small. The negative slope of the line indicates that pH values are decreasing very slightly throughout this dataset. This rate of change is so small that changes in observed pH values would happen over several tens of thousands of measurements. If this relationship holds true with data collected over additional time periods, it would take over a 1.5 years for a realized 1.0 decrease in pH value.

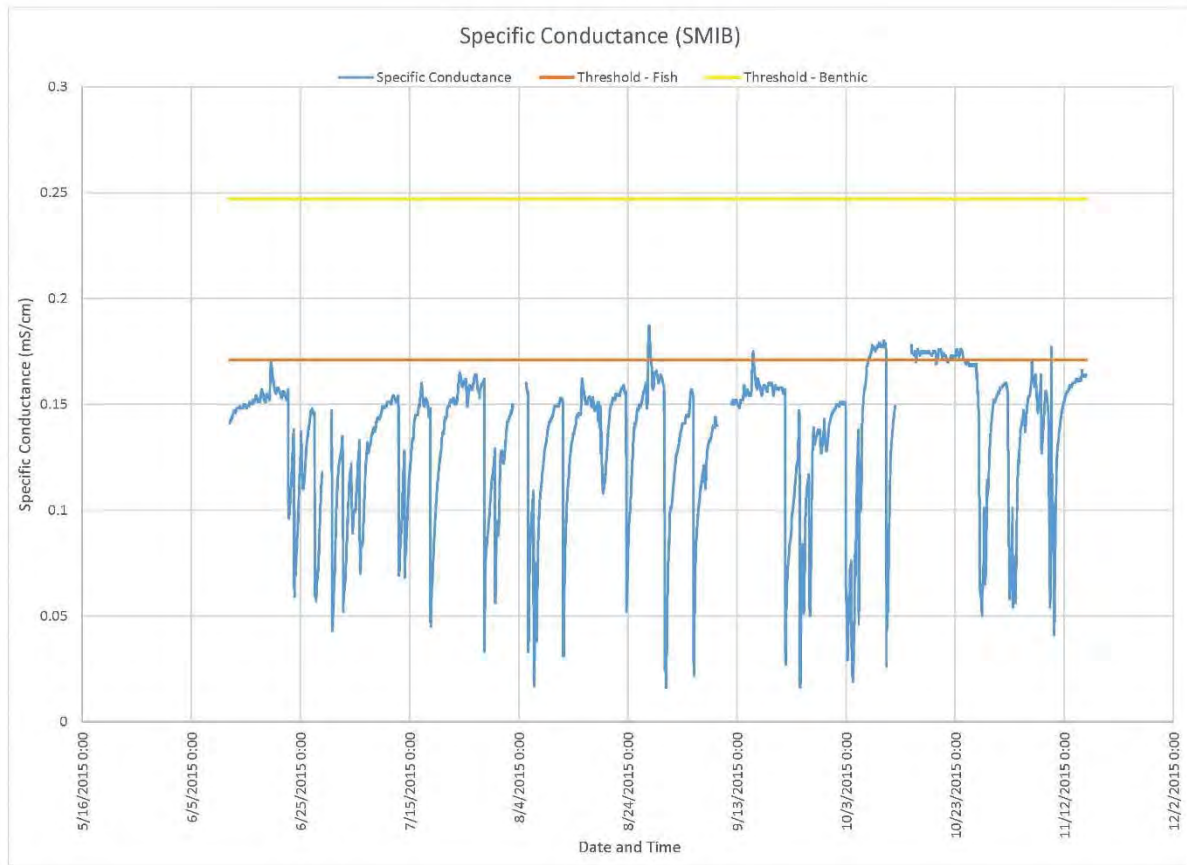
	<i>Coefficients</i>	<i>Standard Error</i>	<i>t Stat</i>	<i>P-value</i>
Intercept	7.288478514	0.004918	1481.932	0
Slope	-1.78904E-05	5.69E-07	-31.460	4.82E-210



Monthly average pH and seasonal average pH were not calculated for this site because there was only five months of data.

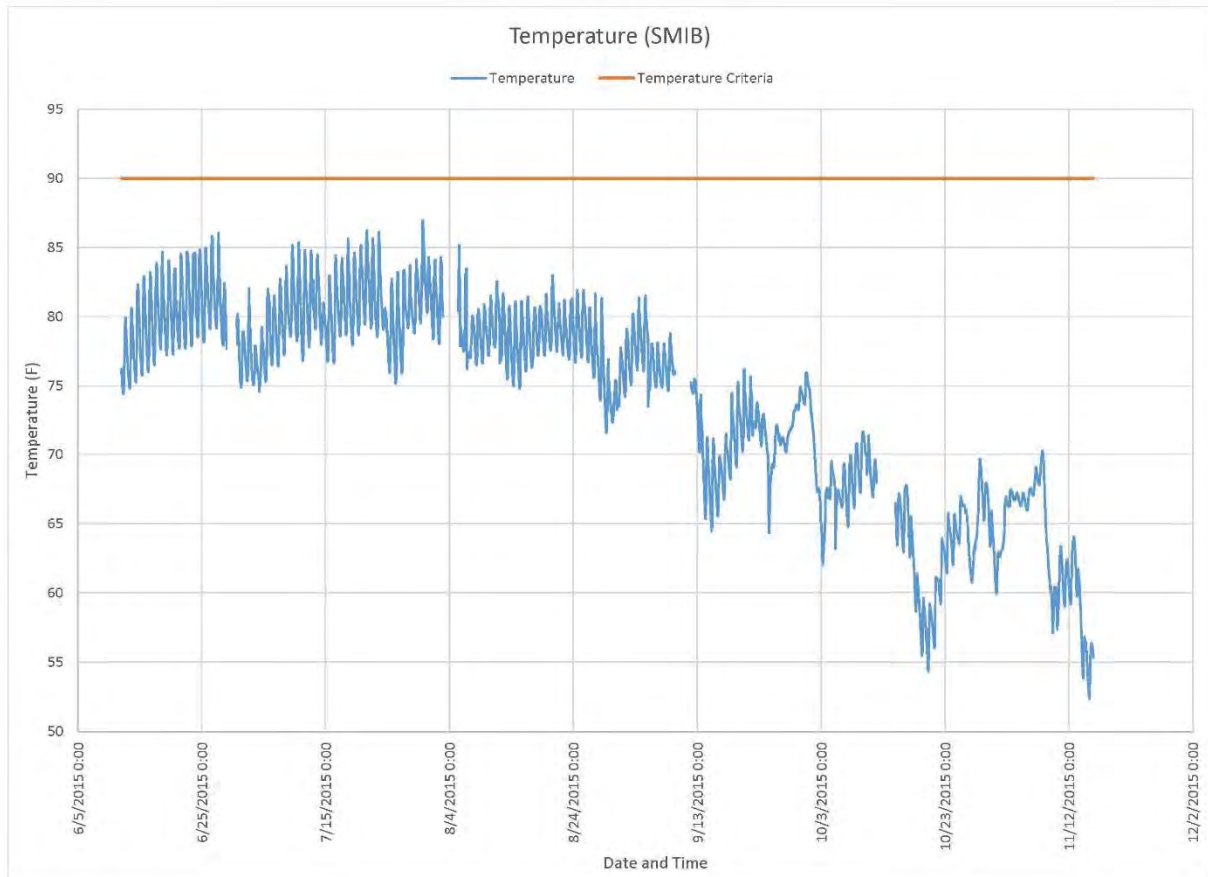
### *Specific Conductance*

South Carolina does not have water quality criteria for specific conductance, which is a measure of dissolved inorganic ions such as chloride, nitrate, sulfate and phosphate anions and sodium, magnesium, calcium, iron, and aluminum cations. Morgan et al., 2007, found biological assemblage impairment thresholds for biological impairment of 0.247 mS/cm for benthic macroinvertebrates and 0.171 mS/cm for fish in urban streams in Maryland. Smith Branch is an urban stream so the impairment thresholds from Maryland data may be applicable. When compared against these values, the possible specific conductance impairment thresholds were exceeded in SMIB for fish assemblage 9.22% of the time (1,304 out of 14,145 total records). Specific conductance was not exceeded for benthic macroinvertebrates.



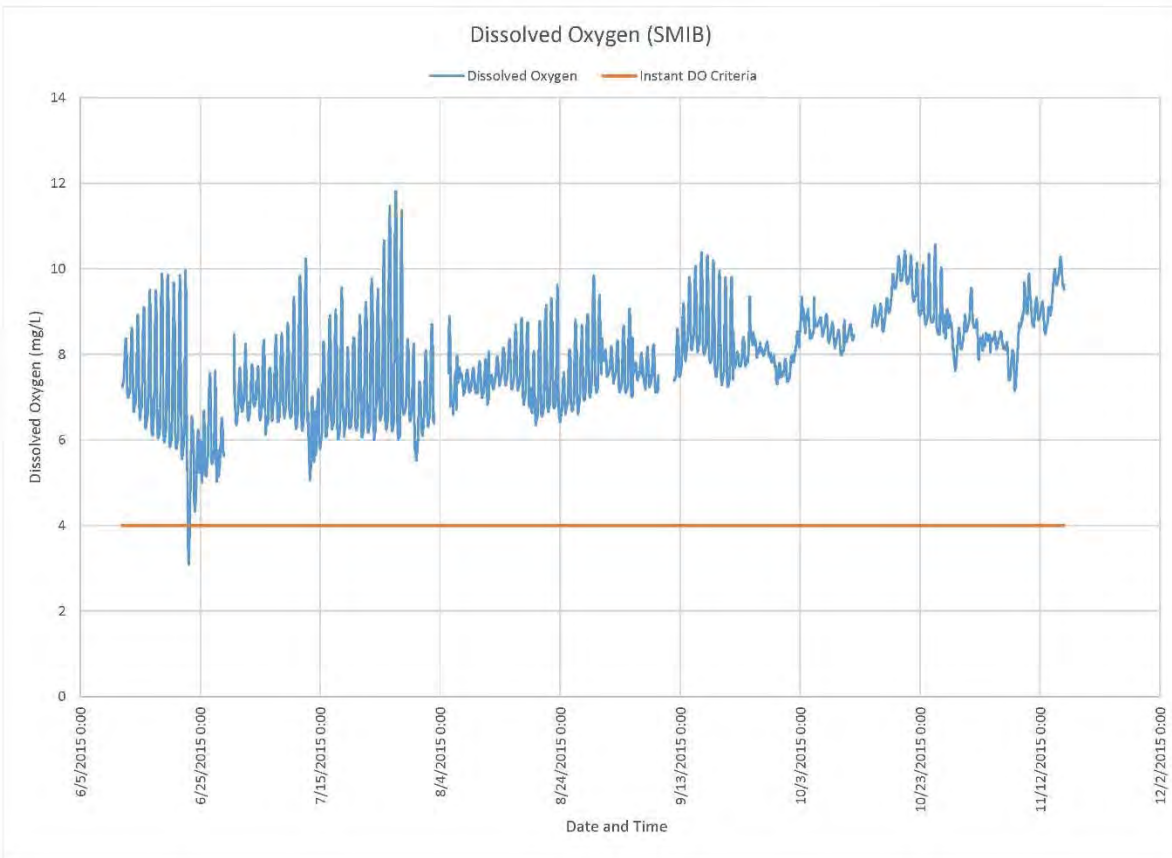
### *Water Temperature*

The water quality criteria for temperature of 90.0° F was not exceeded at SMIB. As expected, there is a seasonal and diurnal pattern to water temperature in Smith Branch. The highest measured water temperatures occurred during the summer time. Summer is the time of the year with the highest air temperatures, and the greatest amount of solar radiation. These factors help warm water throughout the day. The highest temperatures measured each day were in the afternoon. Afternoon is usually the period of time with the highest air temperature, and sunlight has been warming the water and stream substrates throughout the day.



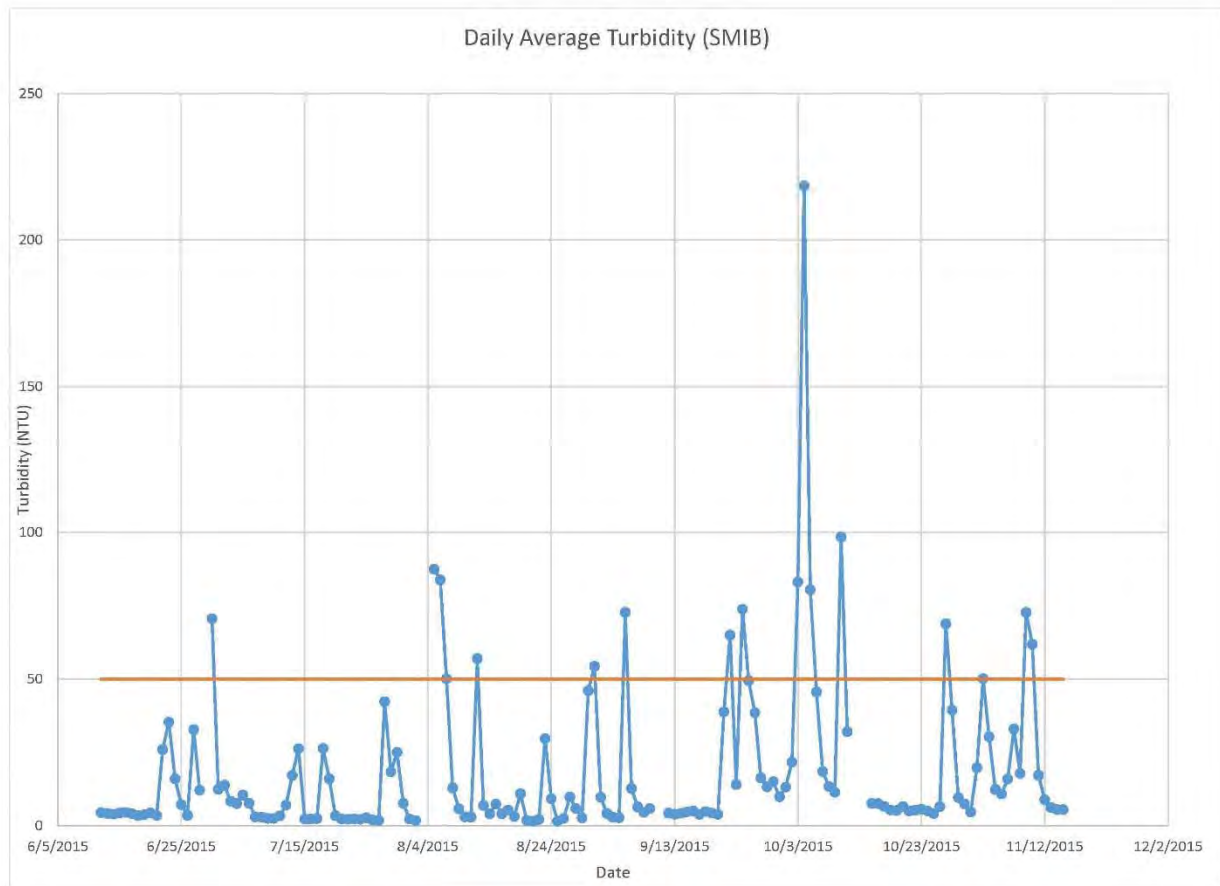
### *Dissolved Oxygen*

Water quality sonde data from site SMIB show that the instantaneous water quality standard for dissolved oxygen of 4.0 mg/L was violated 0.18% of the time (25 out of 14,144 records) over the period of record. Over the same period of time, the water quality standard for daily average dissolved oxygen of 5.0 mg/L was not violated (0 out of 149 days). June 23<sup>rd</sup>, 2015 had the lowest observed daily average dissolved oxygen concentration of 5.12 mg/L.



### *Turbidity*

Water quality sonde data from site SMIB show that water quality standard for turbidity of 50 NTU was violated 8.70 % of the time (1,231 out of 14,144 records) over the period of record. High turbidity values were mostly seen during periods of intense rainfall when stormwater flow increases.



### *E. coli*

Water quality grab samples were collected four times at SMIB and analyzed for *E. coli*. Since there were only four samples over eight months there are too few samples to perform a trend analysis. *E. coli* counts ranged from a high of 18,420 MPN/100mL to a low of 844 MPN/100mL. The mean was  $6630.5 \pm 12897.6$  with a standard deviation of 8105.5.

South Carolina's water quality standard for fecal coliform is a geometric mean of 200 MPN/100mL of five samples collected over a 30-day period. There is no 30-day period throughout the period of record for SMIB where at least five samples were collected. A comparison of means is not possible. The water quality criteria allow for a percentage criteria, where recreational uses are supported if less than 10% of samples exceed 400 MPN/100mL. At SMIB 100 % of samples exceed 400 MPN/100 mL.

### *TSS*

Water quality grab samples were collected at SMIB and analyzed for TSS for 75% of the sampling events (3 of 4 events). These three TSS samples were collected during two days: one sample on October 27<sup>th</sup>,

2015 and two samples on January 15<sup>th</sup>, 2016. The TSS data are too infrequent to allow for any robust statistical analysis. TSS concentrations ranged from a high of 460 mg/L to a low of 105 mg/L. The mean concentration was  $238.7 \pm 479.6$  with a standard deviation of 193.1.

#### *Total Phosphorus*

Water quality grab samples were collected at SMIB and analyzed for total phosphorus (TP) 3 out of 4 (75%) sampling events. These three TSS samples were collected during two days: one sample on October 27<sup>th</sup>, 2015 and two samples on January 15<sup>th</sup>, 2016. The TP data are too infrequent to allow for any robust statistical analysis. TP concentrations ranged from a high of 0.74 mg/L to a low of 0.19 mg/L. The mean concentration was  $0.40 \pm 0.73$  with a standard deviation of 0.30.

#### *Total Nitrogen*

Water quality grab samples were collected at SMIB and analyzed for total nitrogen (TN) 3 out of 4 (75%) sampling events. These three TSS samples were collected during two days: one sample on October 27<sup>th</sup>, 2015 and two samples on January 15<sup>th</sup>, 2016. The TN data are too infrequent to allow for any robust statistical analysis. TN concentrations ranged from a high of 2.94 mg/L to a low of 1.72 mg/L. The mean concentration was  $2.14 \pm 1.72$  with a standard deviation of 0.69.

### **Recommendations to Improve Monitoring**

The following are KCI's recommendations to modify the City of Columbia's water quality monitoring of Smith Branch:

#### *Site Locations*

- No suggested modifications. Two sites located longitudinally along the stream network are appropriate for a small stream such as this.

#### *Quality Control*

- If not already in place, prepare a quality assurance and quality control plan.
- Perform regular calibration and maintenance on data loggers and sondes. Keep a log of when maintenance is performed, and when data loggers or sondes are not deployed.
- Include log with water quality data to help interpret data gaps and suspect data records (e.g. negative turbidity, sudden jumps in pH to near buffer values). Maintenance log information could be stored in a comments field and associated with time intervals closest to maintenance activity.

#### *Parameters - pH, Specific Conductance, Water Temperature, Dissolved Oxygen, Turbidity*

- No suggested modifications to parameters collected via sonde. Collecting these parameters at 15-minute intervals produces a robust data record for analysis.
- Minimize gaps in the data record. Several data gaps from one to four days in duration exist in the data record. Out of 157 days in the data record analyzed, 29 days were missing data (18.5% of days) from SMIA and 11 days were missing data (7.0%) for SMIB. Twenty-one of the missing days for SMIA only had data missing from the specific conductance. Having back-up water quality

sondes and other necessary equipment that can quickly replace broken or malfunctioning equipment will minimize data gaps in the future.

#### Parameter – *E. coli*

- Collect more frequent *E. coli* samples. Across the period of record available for analysis (June 2015 through February 2016) there were only 4 *E. coli* samples collected at site SMIA and 4 at SMIB. This paucity of *E. coli* data severely limited the analysis. The South Carolina water quality standard for *E. coli* is calculated using at least five samples collected over a 30-day period. Not once over the available period of record were samples collected that frequently. Future sampling should attempt to collect at least five samples over a 30-day period each quarter.
- Collect *E. coli* samples more frequently when recreational water contact is most likely. Humans are most likely to have recreational contact with the water during warm-weather periods (e.g. during the summer). Over the summer of 2015 (Memorial Day to Labor Day) only one *E. coli* sample was collected. Future sample collection for *E. coli* should be scheduled to collect more samples during the summer season.
- Collect more *E. coli* samples across a range of stream flow/stage. In urban streams, storm events can affect bacteria concentrations through leaking or broken infrastructure as well as sanitary sewer overflows. More *E. coli* samples during storm events will allow for future analysis of baseflow *E. coli* concentrations versus stormflow concentrations.

#### Parameters – TSS, TP, and TN

- Determine the utility of collecting these parameters for the City's needs. Currently, TSS, TP, and TN data are collected too infrequently to calculate loads, detect trends, or accurately describe current conditions. For these data to be useful in future analysis, samples should be collected monthly at even intervals and during several storm events throughout the year.

#### Parameter - Copper

- Copper could be added as a parameter to water quality grab samples. Collecting copper data will allow the City to assess the contribution of Smith Creek to the copper loading in the Congaree River.

#### Parameter - Mercury

- It is not recommended to add mercury in fish tissue as a parameter to be collected in Smith Branch. Methylation occurs most frequently at the water-sediment interface in wetland and lentic systems. Methylation is the process where elemental mercury is converted to a bioavailable form by anaerobic bacteria. There are no lakes and very little to no wetlands on Smith Branch so methylmercury accumulation in fish tissue is unlikely.

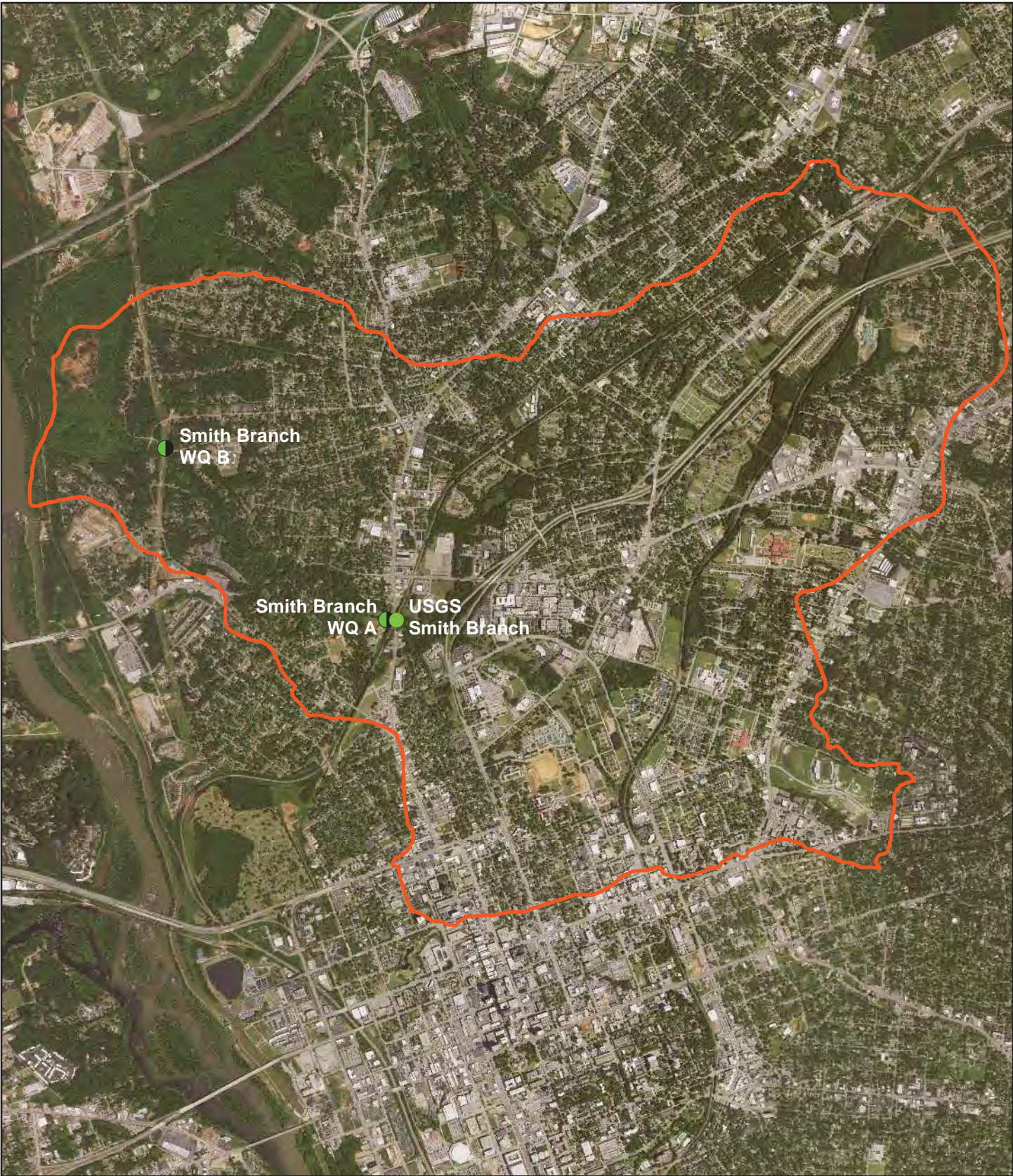
#### Parameter - Discharge

- Stage data collected at SMIA and SMIB could be converted to discharge following development of a stage-discharge rating curve relationship. The relationship can be calibrated and verified using

the nearby USGS station. Discharge would allow for additional calculation of loads for several parameters (e.g. nutrients, metals) given adequate density and frequency of sampling over time and with distribution of sampling events in both baseflow and stormflow periods.

## **References**

Morgan R.P., K.M. Kline, and S.F. Cushman. 2007. Relationships among nutrients, chloride, and biological indices in urban Maryland streams. *Urban Ecosystems* 10:153-177.



**Smith Branch Watershed - Stream and Precipitation Gages**

- Stage/Precipitation
- Stage
- ▭ Watershed Boundary

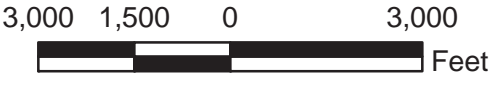


Image Source: USDA NAIP, 2015

---

# Appendix D: Design Solutions

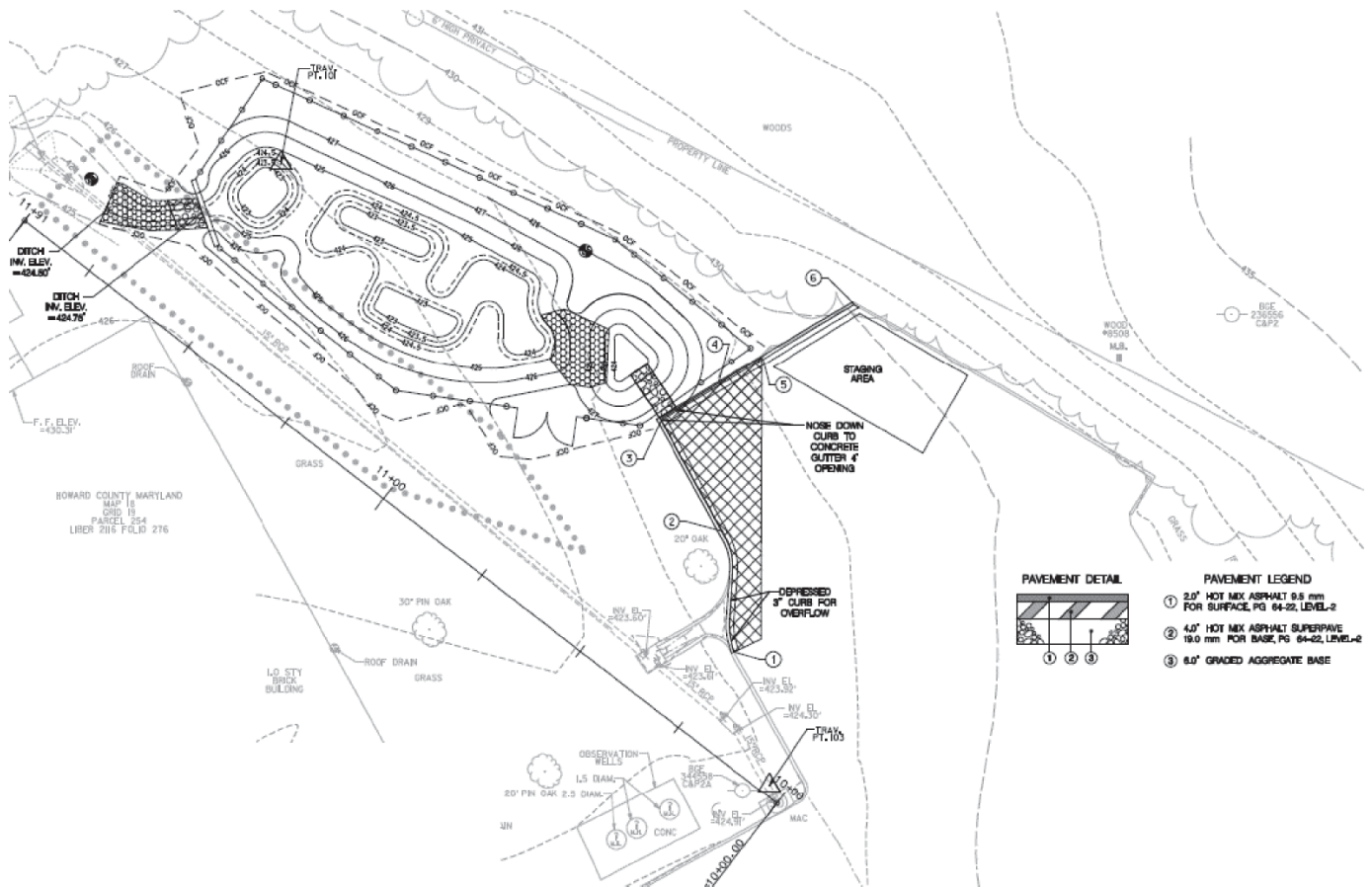
---

---

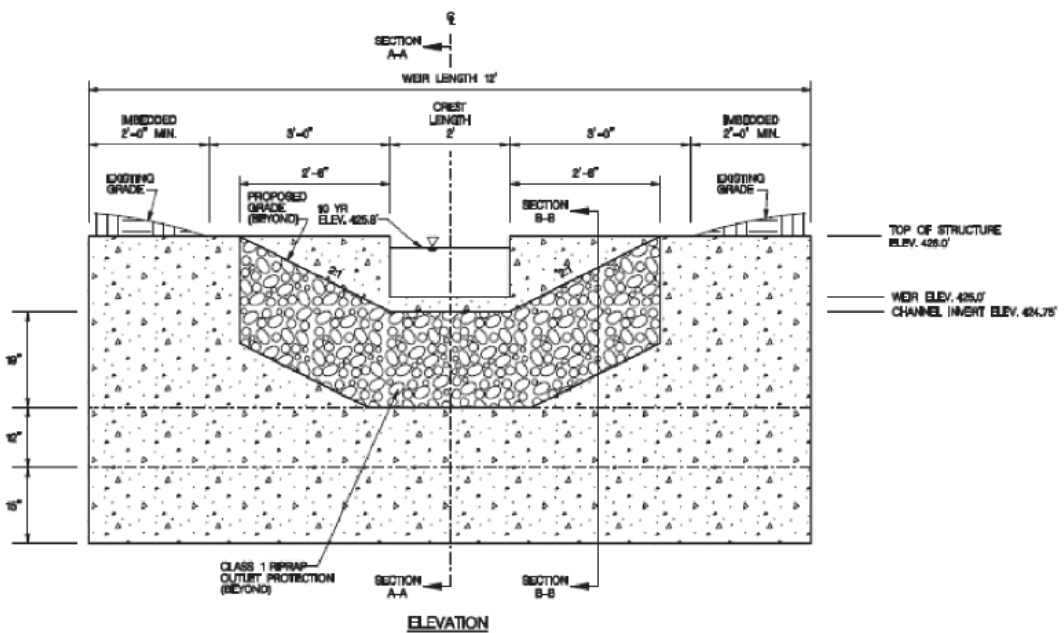
# Appendix D1: Typical Treatments

---

# Stormwater Management Retrofit

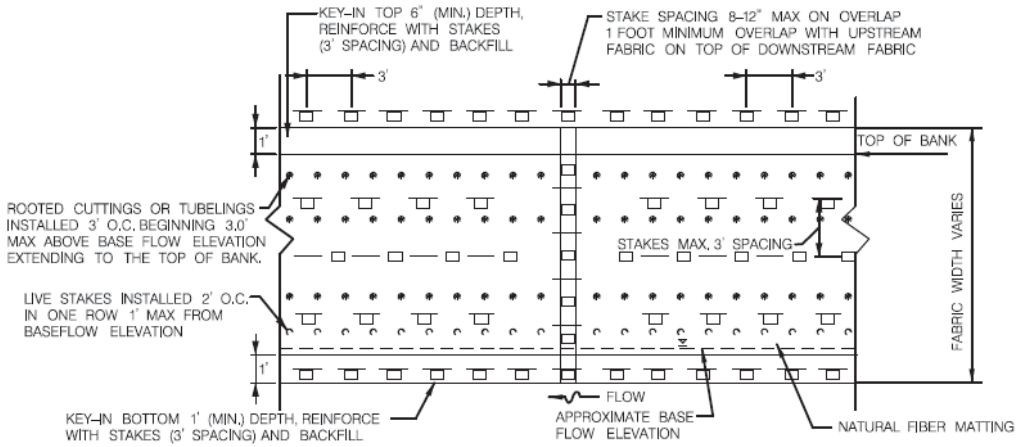


Stormwater Management Retrofit Plan View



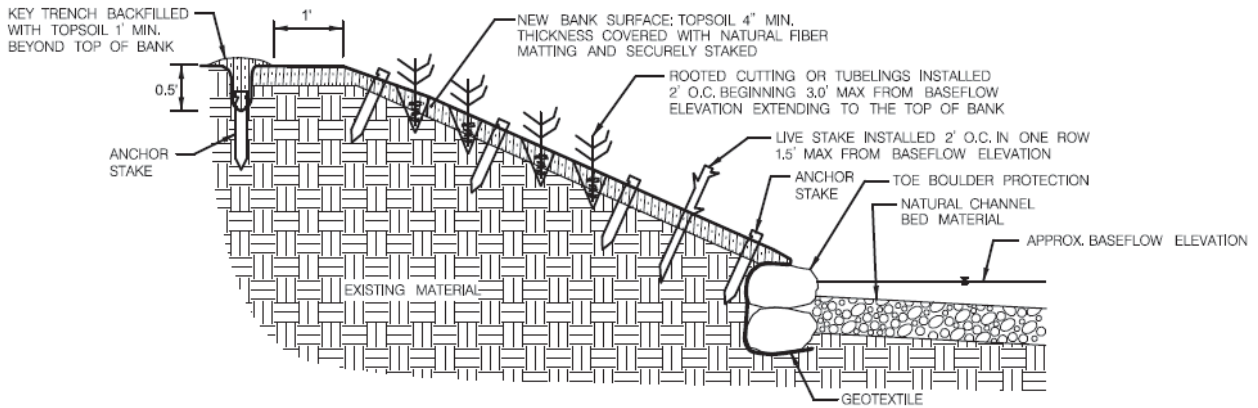
Stormwater Management Retrofit Cross Section

# Stream Restoration: Typical Bank Stabilization



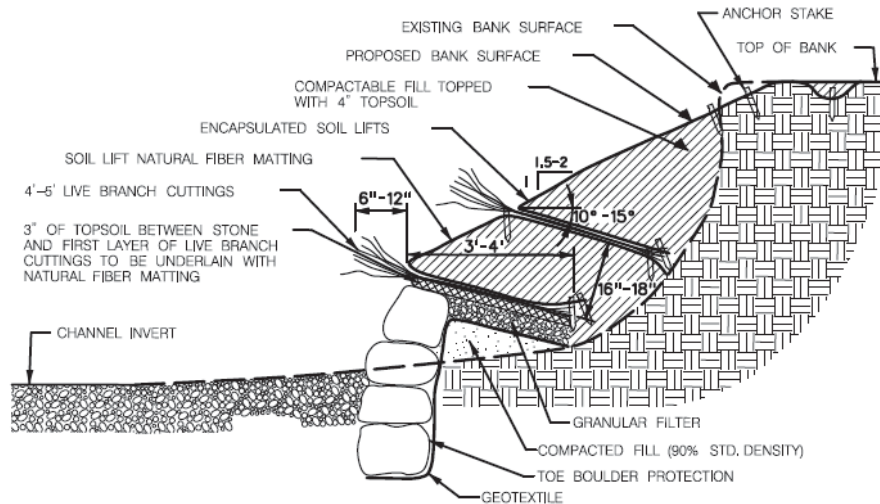
**NATURAL FIBER MATTING – PLAN VIEW**

NOT TO SCALE



**TOE BOULDER PROTECTION TYPICAL**

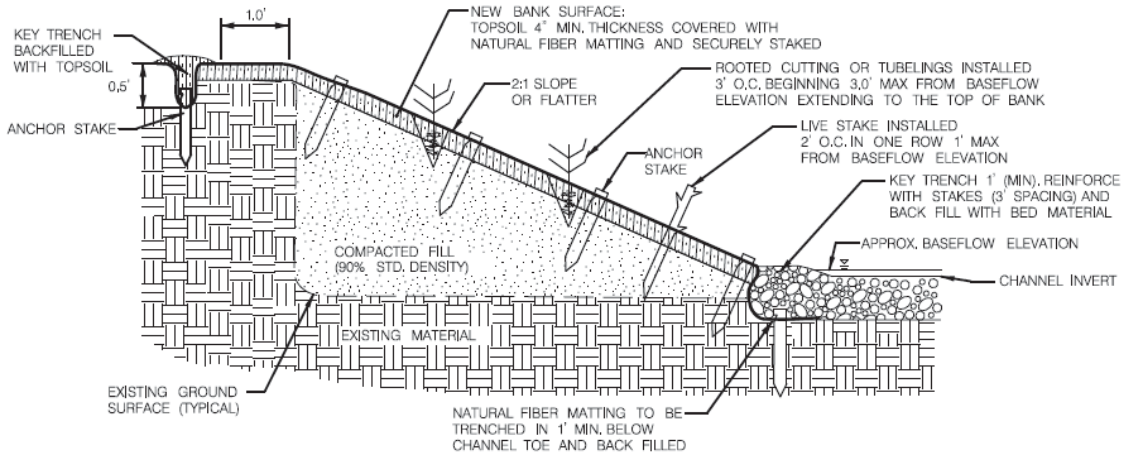
NOT TO SCALE



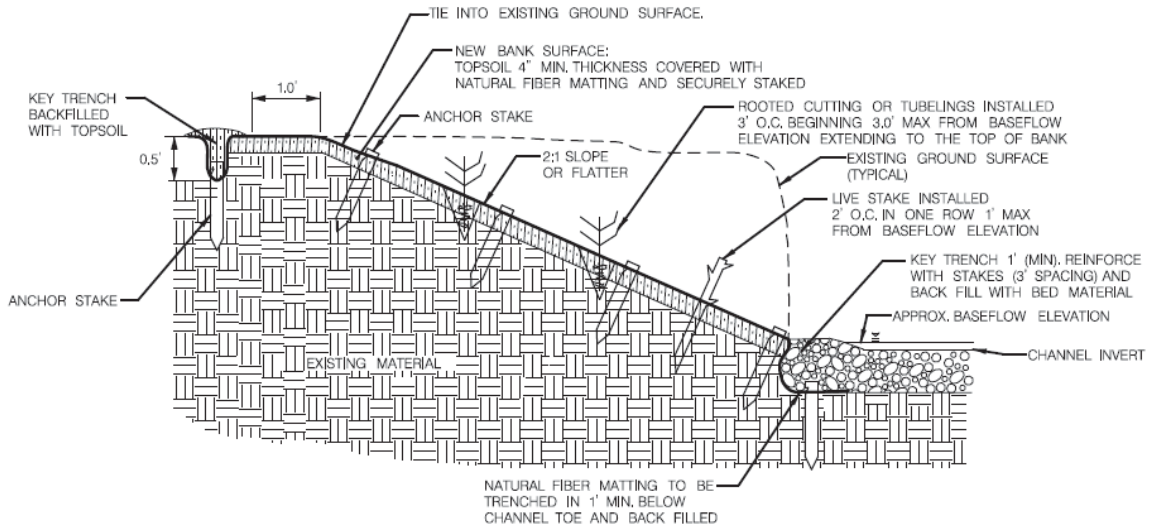
**TOE BOULDER PROTECTION WITH BRANCH LAYERING TYPICAL**

(NOT TO SCALE)

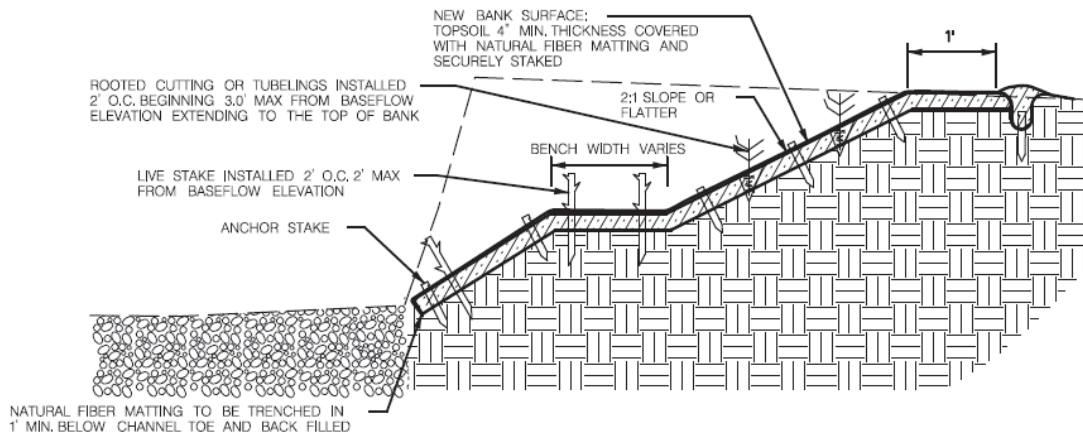
# Stream Restoration: Typical Bank Stabilization



**TYPICAL STREAMBANK STABILIZATION IN FILL**  
NOT TO SCALE

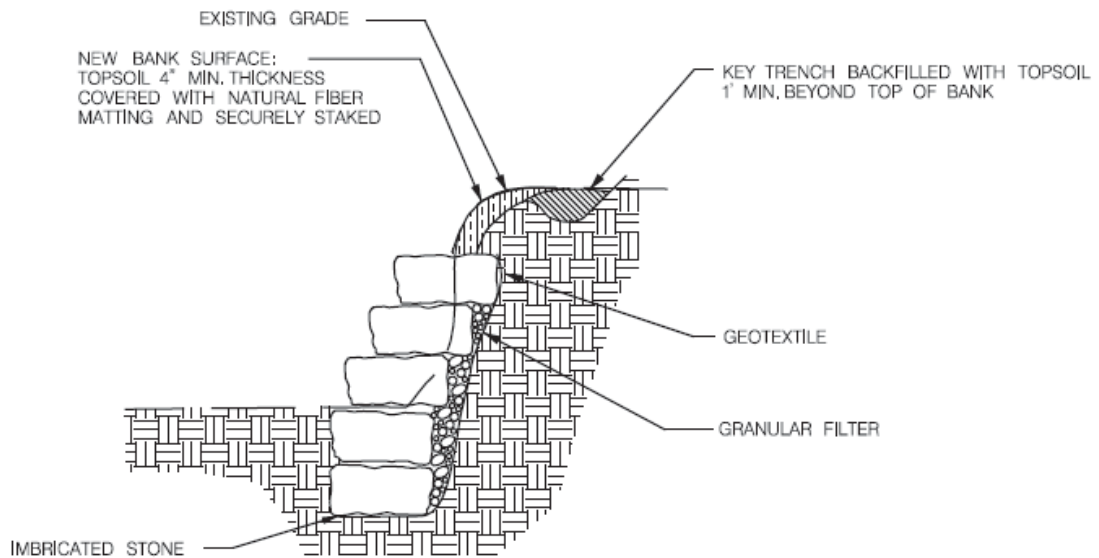


**TYPICAL STREAMBANK STABILIZATION IN CUT**  
NOT TO SCALE



**TYPICAL STREAMBANK STABILIZATION  
WITH FLOODPLAIN BENCH**  
NOT TO SCALE

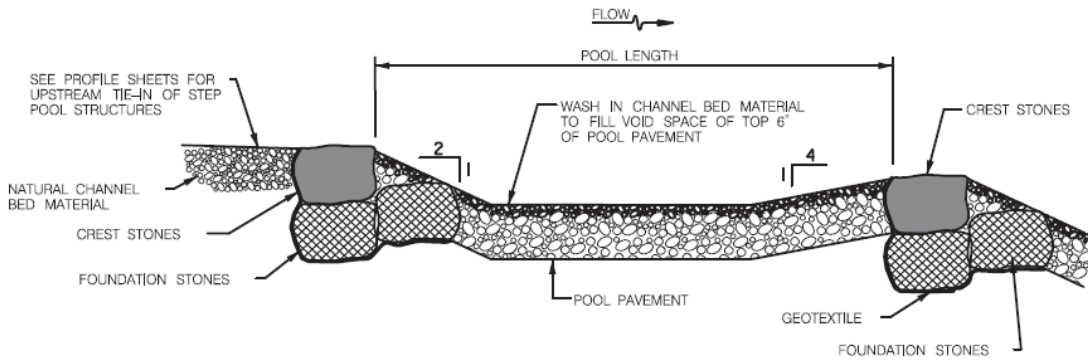
# Stream Restoration: Typical Bank Stabilization



IMBRICATED STONE WALL CHANNEL PROTECTION-SECTION VIEW

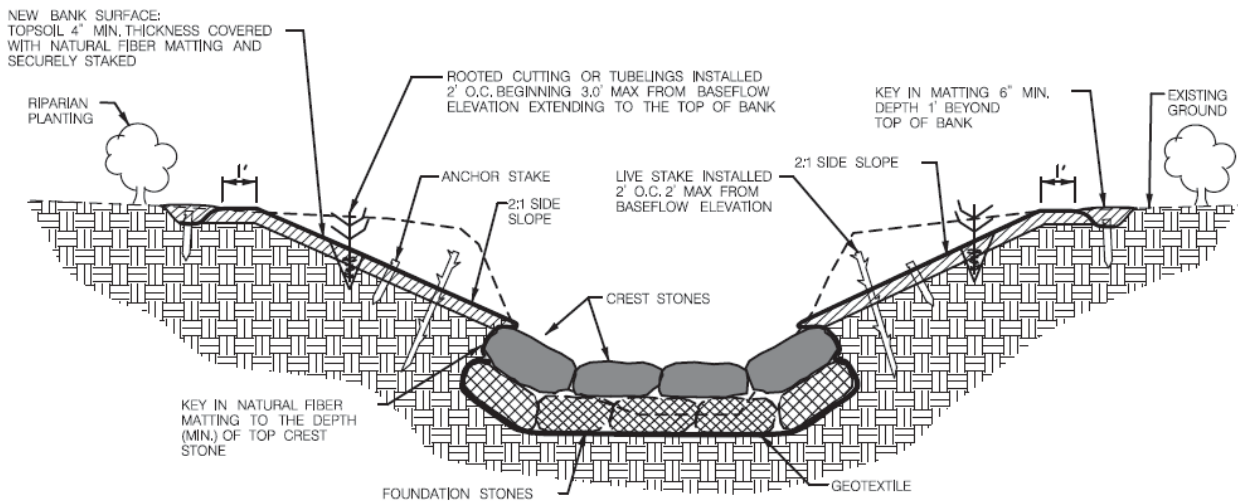
NOT TO SCALE

# Stream Restoration: Step Pool Structure



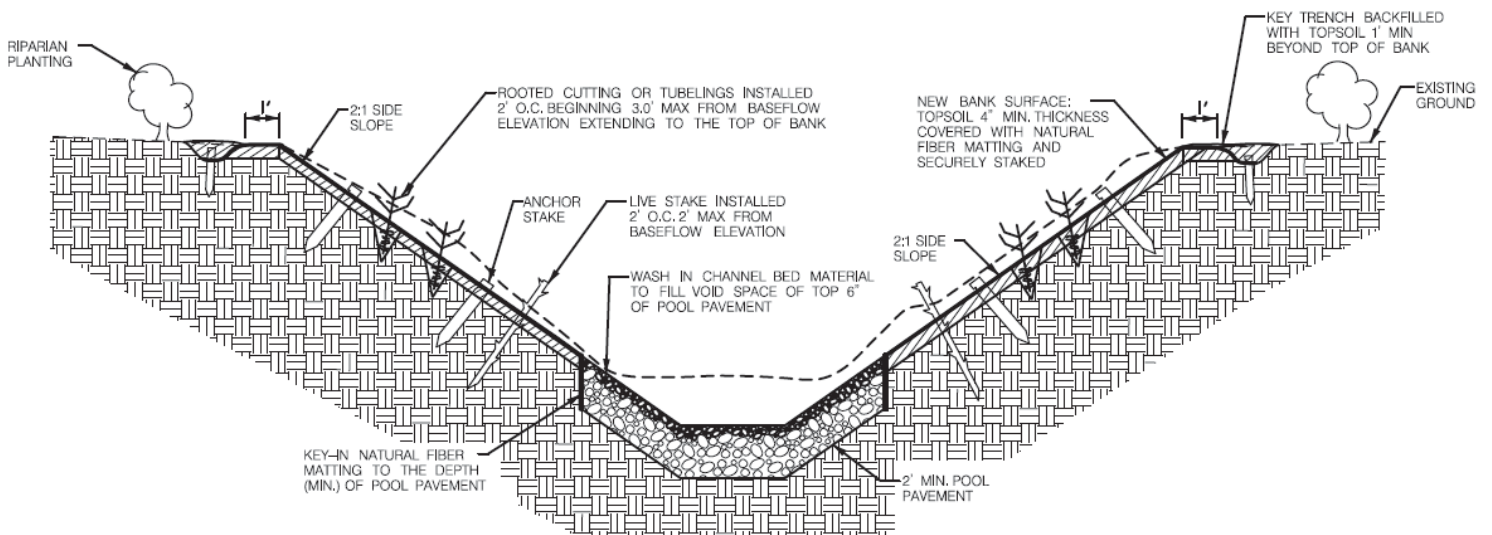
TYPICAL PROFILE THROUGH STEP-POOL

NOT TO SCALE



TYPICAL CROSS SECTION OF STEP-POOL CREST

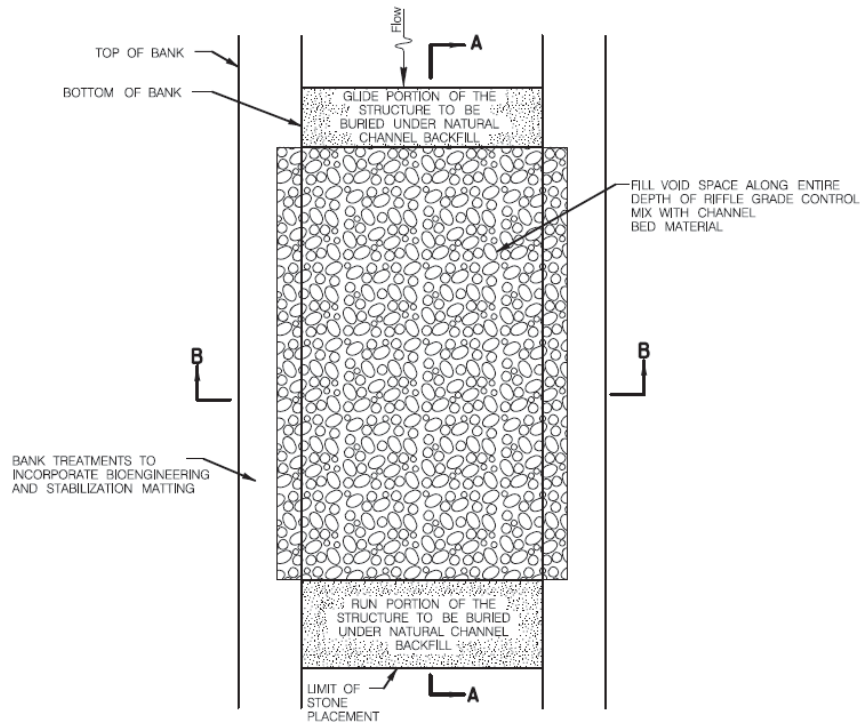
NOT TO SCALE



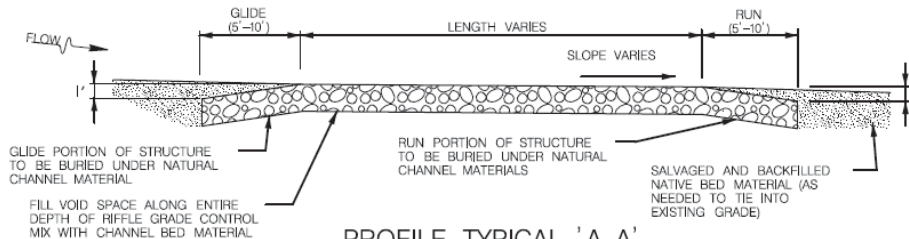
TYPICAL CROSS SECTION OF STEP-POOL POOL

NOT TO SCALE

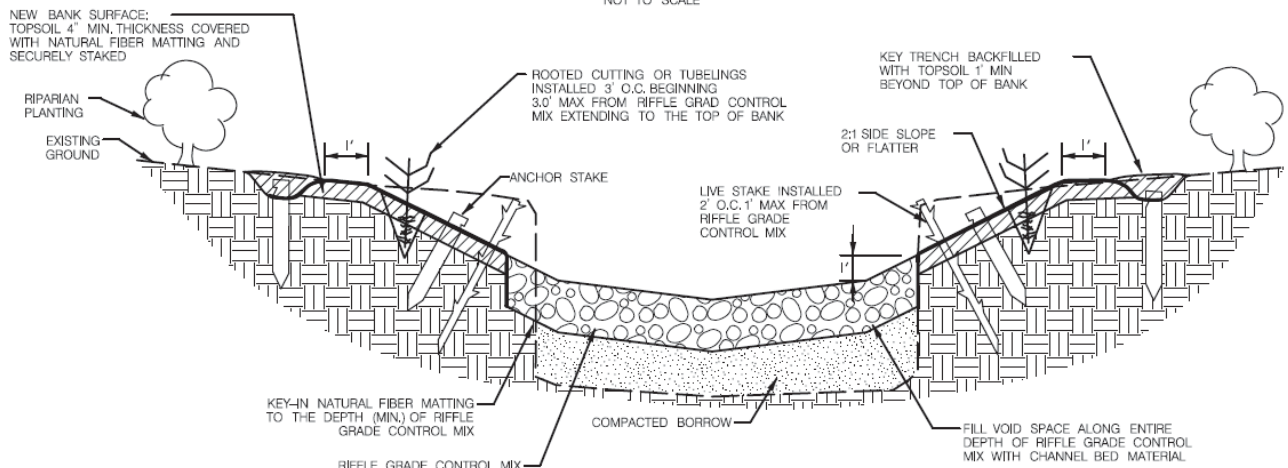
# Stream Restoration: Riffle Grade Control



PLAN VIEW TYPICAL  
RIFFLE GRADE CONTROL  
NOT TO SCALE

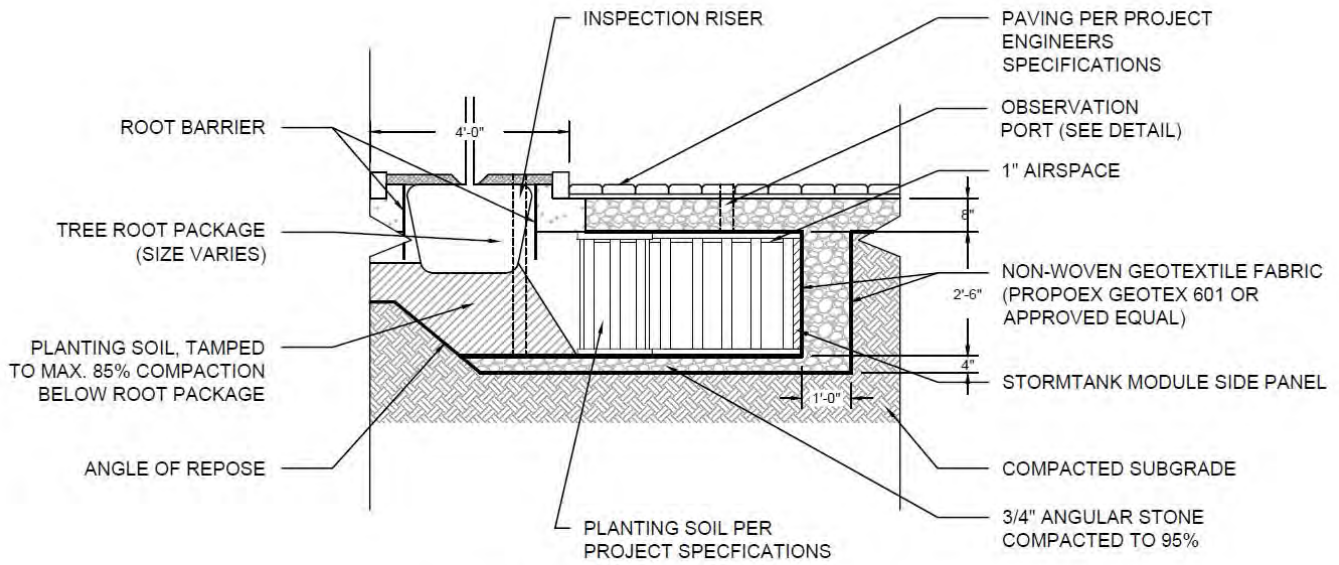


PROFILE TYPICAL 'A-A'  
RIFFLE GRADE CONTROL  
NOT TO SCALE

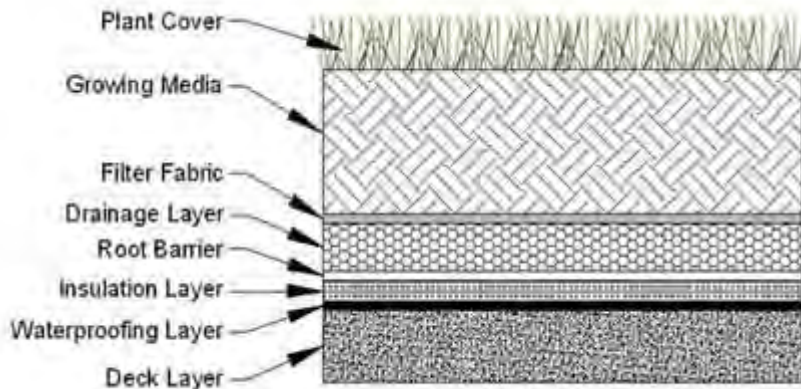


CROSS SECTION TYPICAL 'B-B'  
RIFFLE GRADE CONTROL  
NOT TO SCALE

# LID Treatments: Boulevard Approach and Green Roof Systems

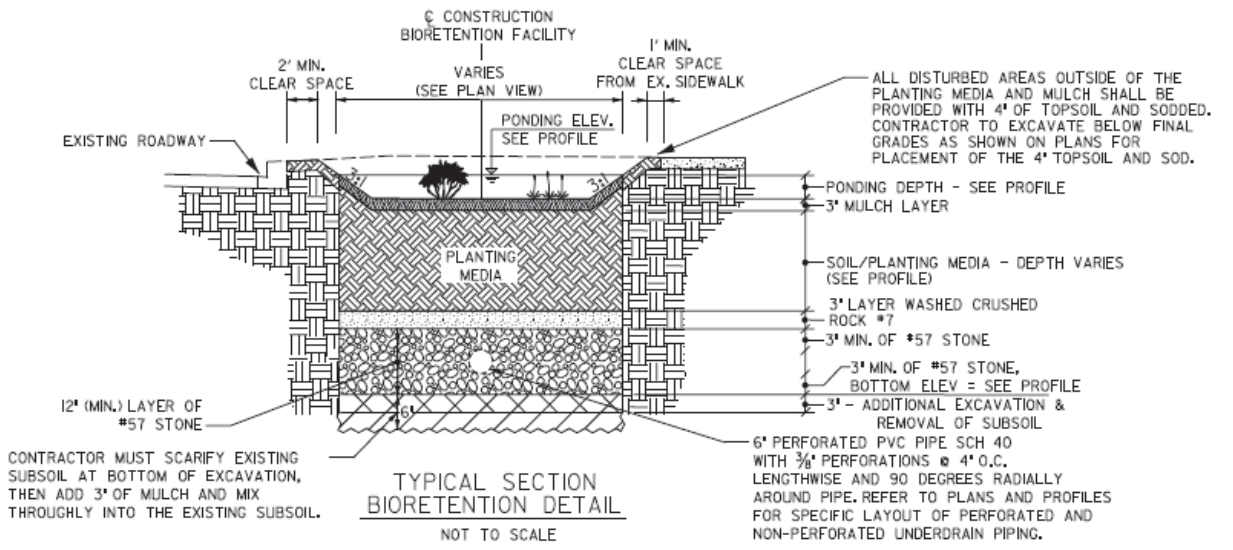
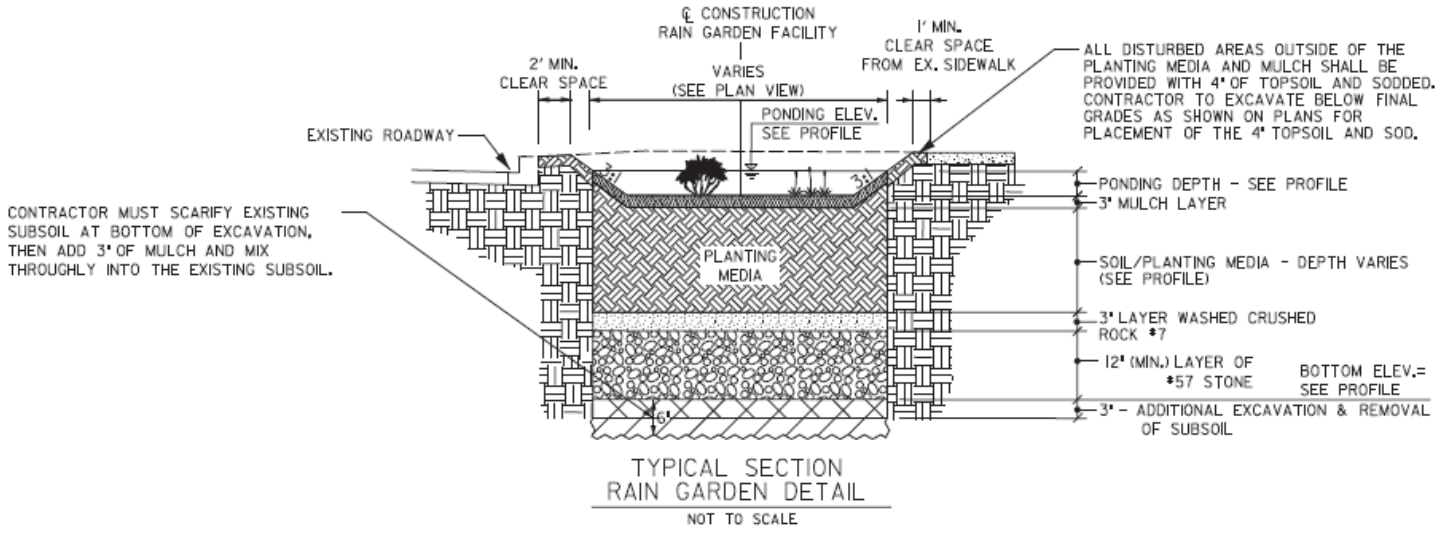


Boulevard Approach  
Tree Boxes

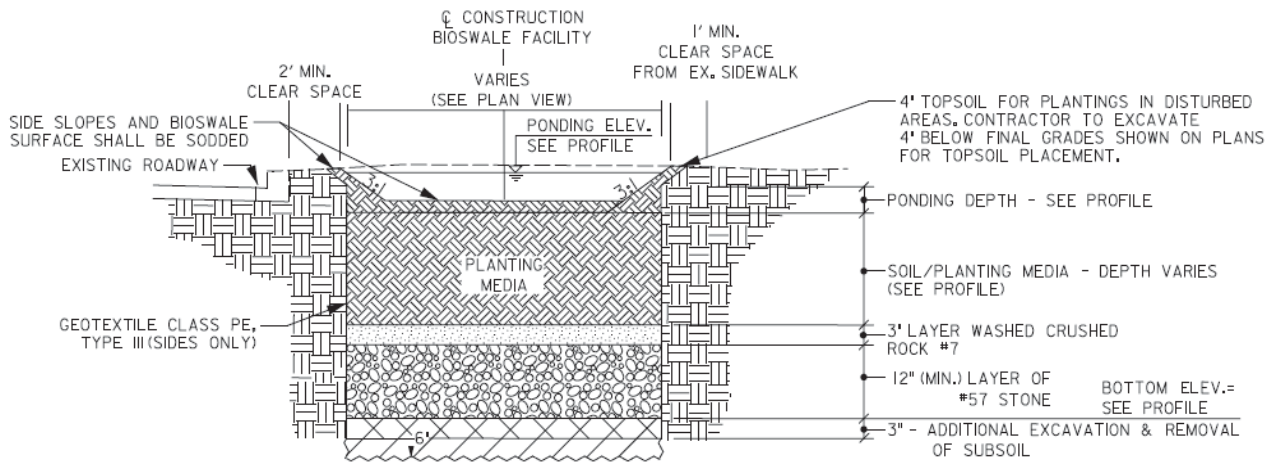


Green Roof System

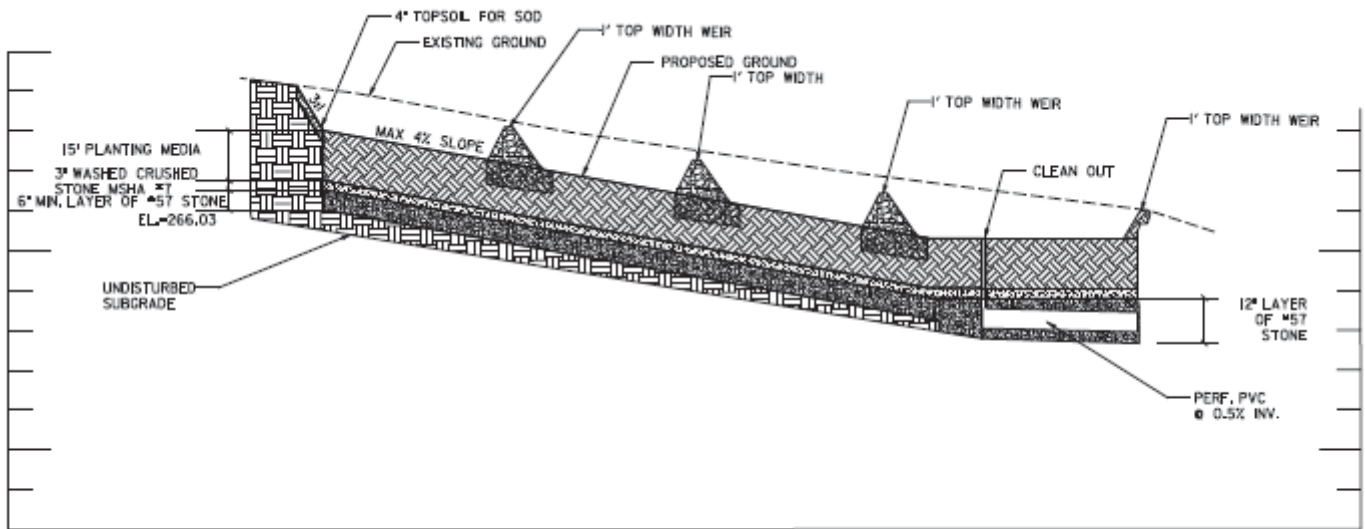
# LID Treatments: Rain Gardens and Bioretention Areas,



# LID Treatments: Bioswales

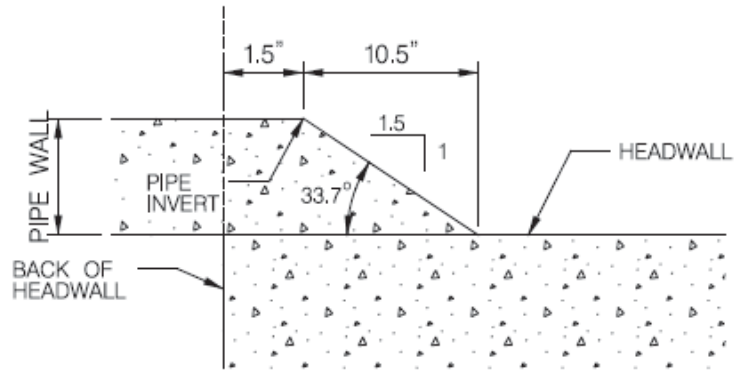


TYPICAL SECTION  
BIOSWALE DETAIL  
NOT TO SCALE



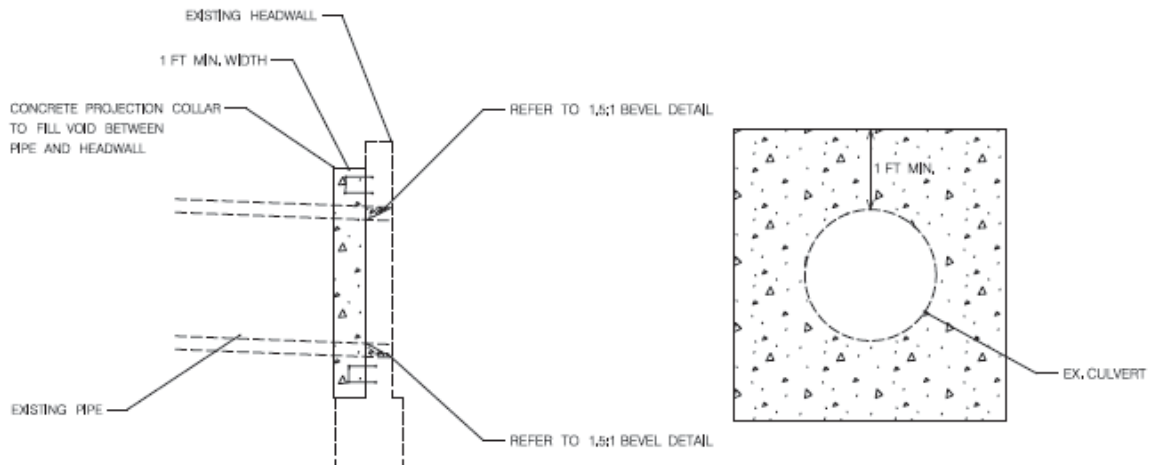
PROFILE A-A - BIOSWALE FACILITY (BMP44)

# LID Treatments: Beveled Edge Repair



## 1.5:1 INLET BEVEL

CONSTRUCT A 1.5:1 BEVEL AROUND ENTIRE CIRCUMFERENCE OF THE CULVERT.

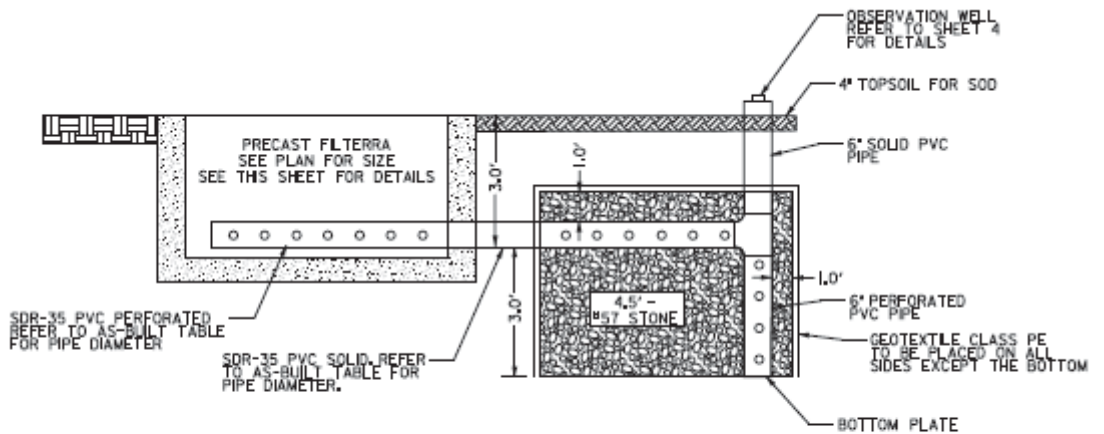
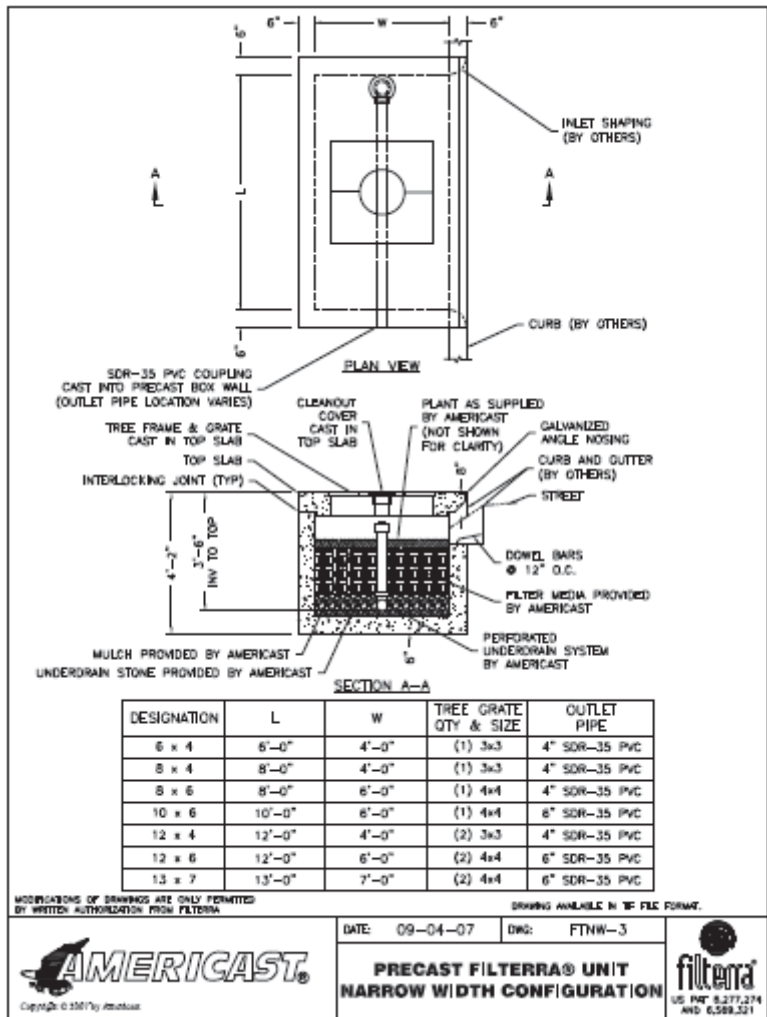


CAST 1 FOOT THICK CONCRETE COLLAR TO HEADWALL WITH 4 U=SHAPED REBARS

## CONCRETE PIPE COLLAR

NOT TO SCALE

# LID Treatments: Infiltration



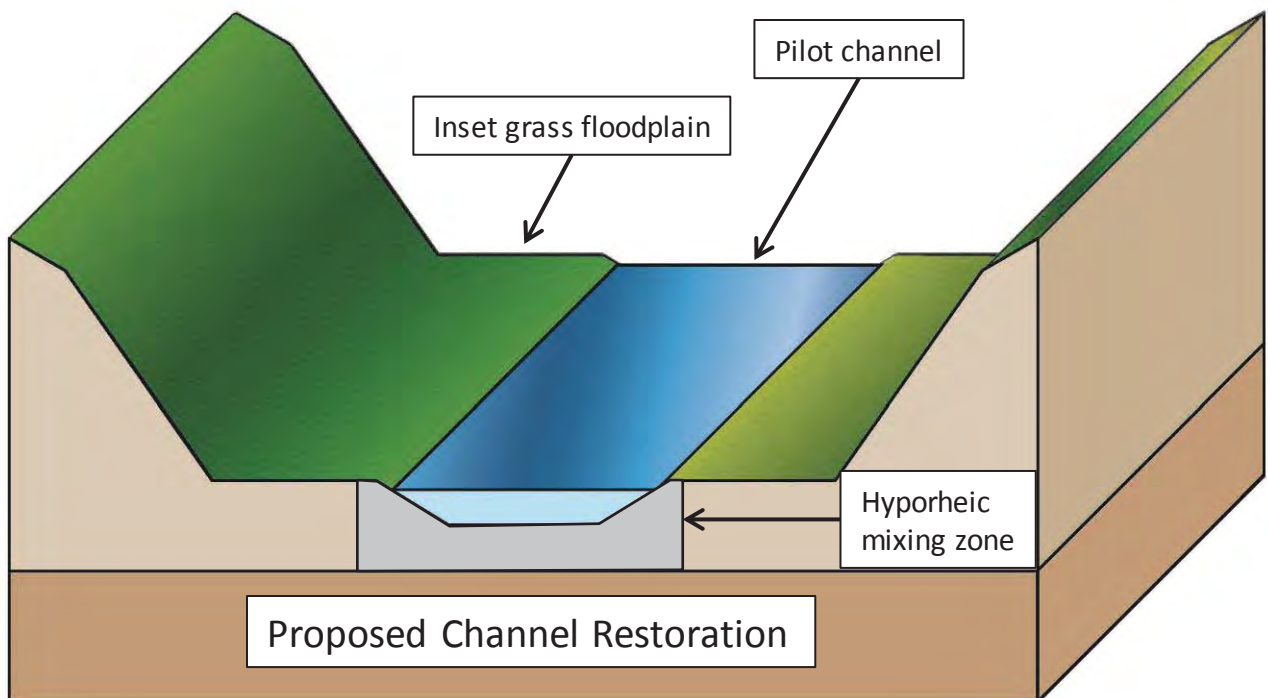
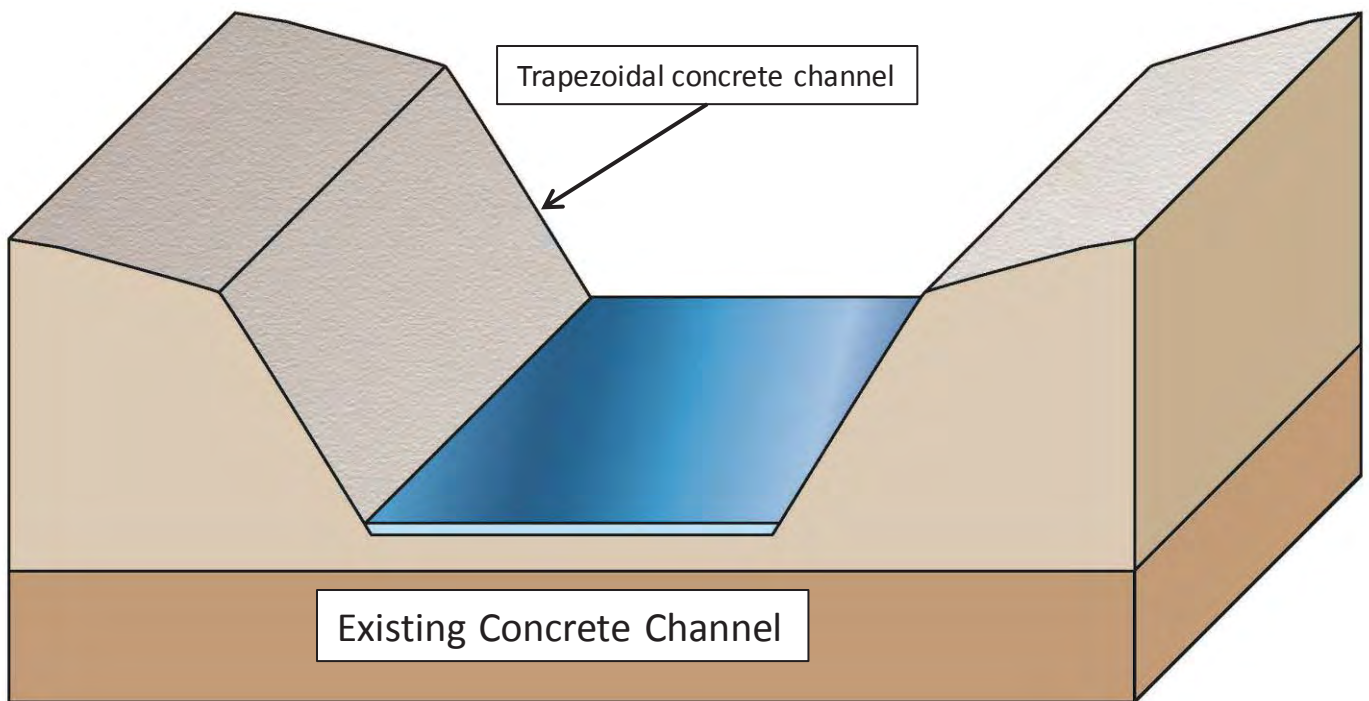
TYPICAL FILTERRA AND STONE TRENCH DETAIL  
NOT TO SCALE

---

# Appendix D2: Project Concepts

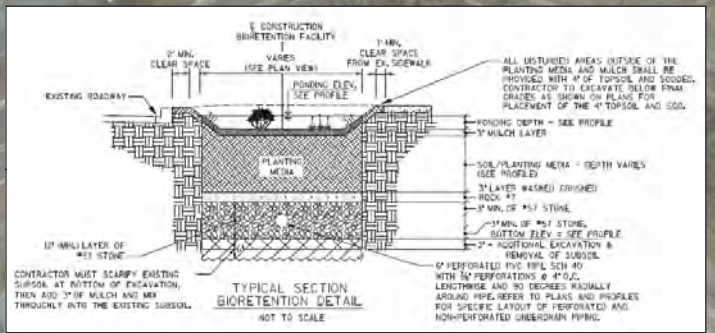
---

# Stream Restoration Concept: Concrete Channel Removal from SW-D



**Legend**

 Proposed BMP





**Smith Branch  
Watershed Assessment**

SC Department of Health  
and Environmental Control Recommended  
Parking Lot Bioretention BMP

0 100 200  
Feet



**Legend**

-  Parking Lot Restriping
-  Parking Lot Removal



**Smith Branch  
Watershed Assessment**

Recommended Parking Lot Removal  
and Restriping North of  
Harden Street Extension

